

# **TURBONutter**

Lada Niva 4x4  
Service Manual  
Fuel Injection

This manual and a host of other wonderful Lada Niva documentation is available free of charge at:

<http://www.turbo-nutter.com>

You can do anything you like with this manual except sell it or otherwise make money from it.

While I can't stop you sticking it on your own website I would much prefer you linked to its original location on turbo-nutter.com

You use the information contained with this manual at you own risk. If you're not sure how to do something either don't do it or ask someone who knows about such things. The font of all Lada knowledge can be found at:

<http://www.lada.co.uk/forum>

For Lada parts, advice and general all round Lada wonderfulness these blokes aren't bad:

Lada UK Ltd  
Askew Rigg  
Troutbeck  
Penrith, Cumbria  
CA11 0SZ  
United Kingdom

T: +44 (0) 17 6877 9794  
F: +44 (0) 17 6877 9197  
E: [alan@lada.co.uk](mailto:alan@lada.co.uk)  
W: <http://www.lada.co.uk>

Lada Parts Australia P/L  
42 Aerodrome Road  
Caboolture  
Queensland  
4510  
Australia

T: +61 7 5495 5100  
F: +61 7 5495 5152  
E: [andy@ladaparts.com](mailto:andy@ladaparts.com)  
W: <http://www.ladaparts.com>



# ENGINE MANAGEMENT SYSTEMS

## 1.7L THROTTLE BODY INJECTION

### TABLE OF CONTENTS

| Ref. Subject                                    | Page | Ref. Subject  | Page |
|---|------|---|------|
| 1 GENERAL DESCRIPTION AND SYSTEM OPERATION..... | 1-1  | Starting Mode.....  | 1-29 |
| GLOSSARY OF TERMS.....                          | 1-4  | Clear Flood Mode.....   | 1-29 |
| 1.1 ELECTRONIC CONTROL MODULE AND SENSORS.....  | 1-8  | Run Open Loop Mode.....   | 1-29 |
| Electronic Control Module.....                  | 1-8  | Run Closed Loop Mode.....   | 1-29 |
| Electronic Control Module Function.....         | 1-8  | Acceleration Enrichment Mode.....   | 1-29 |
| Engine Calibrator.....                          | 1-9  | Power Enrichment Mode.....  | 1-29 |
| Memory.....                                     | 1-9  | Deceleration Enleanment.....  | 1-30 |
| Read Only Memory.....                           | 1-9  | Decel Fuel Cut Mode.....  | 1-30 |
| Random Access Memory.....                       | 1-9  | Battery Voltage Correction Mode.....  | 1-30 |
| Programmable Read Only Memory.....              | 1-9  | Fuel Cutoff Mode.....   | 1-30 |
| Information Sensors.....                        | 1-10 | Adaptive Adjustment Fuel Injector Pulsewidth.....                             | 1-31 |
| Coolant Temperature Sensor.....                 | 1-10 | Closed Loop Fuel Adjustment.....  | 1-31 |
| Intake Air Temperature Sensor.....              | 1-11 | Memory Fuel Adjustment.....   | 1-32 |
| Manifold Absolute Pressure Sensor.....          | 1-12 | Memory Fuel Adjustment Cell.....  | 1-33 |
| Throttle Position Sensor.....                   | 1-14 | 1.3 EVAPORATIVE EMISSION CONTROL SYSTEM.....                                  | 1-35 |
| Oxygen Sensor (Electrically Heated).....        | 1-15 | General Description.....  | 1-35 |
| Crankshaft Position Reference Signal.....       | 1-18 | Purpose.....  | 1-35 |
| Vehicle Speed Sensor.....                       | 1-18 | Evaporative System.....   | 1-35 |
| Octane Adjustment.....                          | 1-19 | Operation.....  | 1-35 |
| Air Conditioning Request Signal.....            | 1-19 | Results of Incorrect Operation.....   | 1-35 |
| 1.2 FUEL CONTROL SYSTEM.....                    | 1-20 | Visual Check of Canister.....   | 1-35 |
| General Description.....                        | 1-20 | 1.4 DIRECT IGNITION SYSTEM.....   | 1-37 |
| Components.....                                 | 1-20 | General Description.....  | 1-37 |
| Fuel Pump.....                                  | 1-21 | Electronic Spark Timing.....  | 1-37 |
| Fuel Filter.....                                | 1-21 | System Components.....  | 1-38 |
| Fuel System Electrical Circuits.....            | 1-21 | Diagnosis.....  | 1-39 |
| Throttle Body Injection Unit.....               | 1-22 | Symptom Diagnosis.....  | 1-39 |
| Fuel Pressure Diagnostic Fitting.....           | 1-22 | 1.9 ELECTRONIC CONTROL MODULE CONTROLLED INTAKE MANIFOLD ELECTRIC HEATER..... | 1-41 |
| Fuel Injector.....                              | 1-23 | General Description.....  | 1-41 |
| Fuel Pressure Regulator.....                    | 1-23 | Operation.....  | 1-41 |
| Fuel Metering.....                              | 1-24 | 1.10 ELECTRONIC CONTROL MODULE CONTROLLED AIR CONDITIONING.....               | 1-42 |
| Throttle Position Sensor.....                   | 1-24 | General Description.....  | 1-42 |
| Idle Air Control Valve.....                     | 1-25 |   |      |
| Speed-Density Fuel Control.....                 | 1-26 |   |      |
| Speed-Density Calculation.....                  | 1-27 |   |      |
| Modes of Fuel Control Operation.....            | 1-28 |   |      |

## 2 - ENGINE MANAGEMENT SYSTEMS 1.7L THROTTLE BODY INJECTION

| Ref. Subject                                    | Page | Ref. Subject                                   | Page |
|---|------|--|------|
| 1.13 CRANKCASE VENTILATION SYSTEM .....         | 1-43 | Throttle Position .....                        | 2-11 |
| General Description .....                       | 1-43 | Throttle Angle .....                           | 2-11 |
| Results of Incorrect Operation .....            | 1-43 | Manifold Absolute Pressure .....               | 2-11 |
| 1.14 THERMOSTATIC AIR CLEANER .....             | 1-44 | Barometric Pressure .....                      | 2-11 |
| General Description .....                       | 1-44 | Oxygen Sensor Voltage .....                    | 2-11 |
| Purpose .....                                   | 1-44 | Exhaust Gases (Rich/Lean) .....                | 2-11 |
| Operation .....                                 | 1-44 | Oxygen Sensor Ready (Yes/No) .....             | 2-11 |
| Results of Incorrect Operation .....            | 1-44 | “Open/Closed Loop” Fuel Control .....          | 2-11 |
| Thermostatic Air Cleaner Functional Check ..... | 1-44 | “Closed Loop” Fuel Adjustment .....            | 2-12 |
| 2 DIAGNOSIS .....                               | 2-1  | Memory Fuel Adjustment .....                   | 2-12 |
| Introduction .....                              | 2-1  | Memory Fuel Adjustment Cell .....              | 2-12 |
| Diagnosis Procedure .....                       | 2-2  | Air Fuel Ratio .....                           | 2-12 |
| 2.1 DIAGNOSTIC PRECAUTIONS .....                | 2-3  | Power Enrichment Mode Active? (Yes/No) .....   | 2-12 |
| 2.2 DIAGNOSTIC GENERAL DESCRIPTION .....        | 2-4  | Decel Fuel Cut Mode in Effect? (Yes/No) .....  | 2-12 |
| “Check Engine” Light .....                      | 2-4  | Evaporative Emission Canister                  |      |
| Intermittent “Check Engine” Light .....         | 2-4  | Purge Duty Cycle .....                         | 2-12 |
| Reading Codes .....                             | 2-5  | Fuel Injector Pulse Width .....                | 2-12 |
| Clearing Codes .....                            | 2-5  | Spark Advance .....                            | 2-12 |
| Diagnostic Display Mode .....                   | 2-5  | Octane Adjust .....                            | 2-12 |
| Field Service Mode .....                        | 2-6  | Idle Air Control Position (0-255) .....        | 2-12 |
| Electronic Control Module                       |      | Vehicle Speed .....                            | 2-12 |
| Adaptive Learning Ability .....                 | 2-6  | Radiator Fan .....                             | 2-12 |
| Diagnosis Procedure .....                       | 2-7  | Intake Manifold Heater (“ON/OFF”) Clutch ..... | 2-12 |
| Diagnostic Circuit Check .....                  | 2-7  | System Voltage .....                           | 2-12 |
| 2.3 TECH 1 “SCAN” TOOL DESCRIPTION .....        | 2-8  | Air Conditioning Request (Yes/No) .....        | 2-13 |
| Tech 1 “Scan” Tool .....                        | 2-8  | Air Conditioning (“ON/OFF”) Clutch .....       | 2-13 |
| Tech 1 “Scan” Tool Explanation .....            | 2-8  | Fuel Pump Circuit (“ON/OFF”) .....             | 2-13 |
| Tech 1 “Scan” Tool Uses .....                   | 2-8  | Calibration Identification .....               | 2-13 |
| Tech 1 “Scan” Tool Use With Intermittents ..... | 2-8  | Time From Start .....                          | 2-13 |
| Additional Tech 1 Functions .....               | 2-8  | 2.4 UNDERHOOD LOCATION VIEWS .....             | 2-14 |
| Tech 1 “Scan” Tool Limitations .....            | 2-9  | 2.5 FUSE BLOCK VIEWS .....                     | 2-15 |
| Diagnostic Modes .....                          | 2-10 | 2.6 RELAY CALLOUT AND LOCATION VIEW .....      | 2-16 |
| Diagnostic Display Mode .....                   | 2-10 | ENGINE MANAGEMENT SYSTEMS                      |      |
| Field Service Mode .....                        | 2-10 | WIRING DIAGRAMS .....                          | 2-17 |
| Tech 1 “F0: Data List” Parameters .....         | 2-10 | 2.7 ELECTRONIC CONTROL MODULE CONNECTOR        |      |
| Tech 1 “F0: Data List” .....                    | 2-10 | IDENTIFICATION CHARTS .....                    | 2-22 |
| Engine Speed .....                              | 2-10 | 2.8 ELECTRONIC CONTROL MODULE                  |      |
| Desired Idle .....                              | 2-11 | TERMINALS DEFINED .....                        | 2-24 |
| Coolant Temperature .....                       | 2-11 | Electronic Control Module Connector            |      |
| Intake Air Temperature .....                    | 2-11 | Voltages With Explanations .....               | 2-24 |

## ENGINE MANAGEMENT SYSTEMS 1.7L THROTTLE BODY INJECTION - 3

| Ref. Subject   | Page | Ref. Subject   | Page  |
|--|------|--|-------|
| <b>2.9A DIAGNOSTIC CHARTS</b> .....  | 2-29 | <b>2.9B SYMPTOM CHARTS</b> .....                                     | 2-95  |
| Diagnostic Charts Defined .....  | 2-30 | Important Preliminary Checks .....                                   | 2-96  |
| Tech 1 "Scan" Tool Typical Data Value .....  | 2-32 | Before Starting .....  | 2-96  |
| Tech 1 "Scan" Data .....   | 2-33 | Intermittents .....  | 2-97  |
| Electronic Control Module Diagnostic Codes .....   | 2-35 | Hard Start .....   | 2-99  |
| Chart A - Diagnostic Circuit Check .....   | 2-36 | Surges and/or Chuggles .....   | 2-101 |
| Chart A-1 - No "Check Engine" Light .....  | 2-38 | Lack of Power, Sluggish, or Spongy .....                             | 2-102 |
| Chart A-2 - No Assembly Line Data Link Serial<br>Data Or Will Not Flash Code 12<br>( "Check Engine" Light "ON" Steady) ..... | 2-40 | Detonation/Spark Knock .....   | 2-104 |
| Chart A-3 - Engine Cranks But Will Not Run .....   | 2-42 | Hesitation, Sag, Stumble .....                                       | 2-106 |
| Chart A-4 - Ignition Relay and Power<br>Circuits Check .....   | 2-48 | Cuts Out, Misses .....   | 2-107 |
| Chart A-5 - Fuel System Electrical Circuit Check .....   | 2-52 | Poor Fuel Economy .....  | 2-108 |
| Chart A-7 - Fuel System Diagnosis .....  | 2-54 | Stalling, Rough, Unstable or Incorrect Idle .....                    | 2-109 |
| Code 13 - No Oxygen Sensor Signal .....  | 2-58 | Excessive Exhaust Emissions or Odors .....                           | 2-111 |
| Code 14 - Coolant Temperature Sensor<br>(Signal Voltage Too Low) .....   | 2-60 | Dieseling, Run-On .....  | 2-112 |
| Code 15 - Coolant Temperature Sensor<br>(Signal Voltage Too High) .....  | 2-62 | Backfire .....   | 2-113 |
| Code 21 - Throttle Position<br>(Signal Voltage Too High) .....   | 2-64 | Chart B-1 Restricted Exhaust System Check .....                      | 2-114 |
| Code 22 - Throttle Position<br>(Signal Voltage Too Low) .....  | 2-66 | Electronic Control Module Pin Connector<br>"A" Symptom Chart .....   | 2-115 |
| Code 23 - Intake Air Temperature<br>(Signal Voltage Too High) .....  | 2-68 | Electronic Control Module Pin Connector<br>"B" Symptom Chart .....   | 2-116 |
| Code 24 - No Vehicle Speed Signal .....  | 2-70 | Electronic Control Module Pin Connector<br>"C" Symptom Chart .....   | 2-117 |
| Code 25 - Intake Air Temperature<br>(Signal Voltage Too Low) .....   | 2-72 | Electronic Control Module Pin Connector<br>"D" Symptom Chart .....   | 2-118 |
| Code 33 - Manifold Absolute Pressure<br>(Signal Voltage Too High) .....  | 2-74 | <b>2.9C COMPONENT SYSTEM CHARTS</b> .....                            | 2-119 |
| Code 34 - Manifold Absolute Pressure<br>(Signal Voltage Too Low) .....   | 2-76 | Chart C-1D Manifold Absolute Pressure<br>Output Check .....          | 2-120 |
| Code 35 - Idle Speed Error .....   | 2-78 | Chart C-1H Throttle Position Sensor<br>Output Check .....            | 2-122 |
| Code 42 - Electronic Spark Timing Control<br>Circuit Problem .....   | 2-80 | Chart C-2C Idle Air Control Circuit Check .....                      | 2-124 |
| Code 44 - Lean Exhaust Indication .....  | 2-82 | Chart C-3 Canister Purge Valve Check .....                           | 2-126 |
| Code 45 - Rich Exhaust Indication .....  | 2-84 | Chart C-4 Ignition System Check<br>(No Spark) (1 of 2) .....         | 2-128 |
| Code 51 - Calibrator Error .....   | 2-86 | Chart C-4B Direct Ignition System<br>Misfire <u>At Idle</u> .....    | 2-132 |
| Code 53 - System Voltage Too High .....  | 2-88 | Chart C-4C Direct Ignition System<br>Misfire <u>Under Load</u> ..... | 2-136 |
| Code 54 - Octane Adjustment (Signal<br>Voltage Too High or Too Low) .....  | 2-90 | Chart C-9 Intake Manifold Electric Heater .....                      | 2-138 |
| Code 55 - Electronic Control Module Error .....  | 2-94 | Chart C-10 Air Conditioning Compressor<br>Clutch Control .....       | 2-142 |
|  |      | Chart C-13 Crankcase Ventilation<br>System Check .....               | 2-144 |
|  |      | Chart C-15 Octane Adjustment<br>Potentiometer Check .....            | 2-146 |

## 4 - ENGINE MANAGEMENT SYSTEMS 1.7L THROTTLE BODY INJECTION

| Ref. | Subject   | Page | Ref. | Subject  | Page |
|------|---|------|------|--|------|
| 3    | <b>SERVICE OPERATIONS</b> .....   | 3-1  | 3.2  | <b>FUEL CONTROL SYSTEM</b> .....                 | 3-26 |
|      | Service Precautions.....  | 3-1  |      | Fuel Control.....                                | 3-26 |
|      | Driveability and Emissions Control.....                                   | 3-1  |      | On-Vehicle Service.....                          | 3-26 |
|      | Maintenance Schedule.....   | 3-1  |      | General Service Information.....                 | 3-26 |
|      | Blocking Drive Wheels.....  | 3-1  |      | Service Identification.....                      | 3-27 |
|      | What This Section Contains.....   | 3-1  |      | Fuel Pressure Relief Procedure.....              | 3-28 |
|      | Visual/Physical Underhood Inspection.....                                 | 3-1  |      | Fuel System Pressure Test.....                   | 3-28 |
|      | Service Precautions.....  | 3-1  |      | Throttle Body Injection Unit.....                | 3-30 |
|      | Electrostatic Discharge Damage.....                                       | 3-2  |      | Fuel Injector Assembly.....                      | 3-33 |
|      | Repair Procedures.....  | 3-2  |      | Pressure Regulator Assembly.....                 | 3-34 |
|      | Electrical Repairs.....   | 3-2  |      | Fuel Meter Assembly.....                         | 3-35 |
|      | Circuit Protection.....   | 3-3  |      | Throttle Position Sensor.....                    | 3-36 |
|      | Circuit Protection Devices.....   | 3-3  |      | Idle Air Control Valve.....                      | 3-36 |
|      | Fuses.....  | 3-3  |      | Tube Module Assembly.....                        | 3-37 |
|      | Typical Electrical Repairs.....   | 3-5  |      | Throttle Body Assembly.....                      | 3-37 |
|      | Short Circuits Caused by Damaged Wire-<br>Insulation.....                 | 3-5  |      | Fuel Pump.....                                   | 3-38 |
|      | Replacing Terminals on Unsealed Components.....                           | 3-5  |      | Fuel Pump Electrical Circuit.....                | 3-39 |
|      | Replacing Pigtails on Sealed Components.....                              | 3-5  |      | Fuel System Relay.....                           | 3-39 |
|      | Replacing Connector Housings On<br>Unsealed Components.....               | 3-6  |      | Fuel Filter.....                                 | 3-40 |
|      | Splicing Copper Wire Using Splice Clips,<br>Shrink Tube and Hot Melt..... | 3-8  | 3.3  | <b>EVAPORATIVE EMISSION CONTROL SYSTEM</b> ..... | 3-41 |
|      | Splicing Twisted/Shielded Cable.....                                      | 3-10 |      | On-Vehicle Service.....                          | 3-41 |
|      | Repairing Connectors.....   | 3-11 |      | Visual Check of Canister.....                    | 3-41 |
|      | Push-To-Seat and Pull-To-Seat.....  | 3-11 |      | Fuel Vapor Canister.....                         | 3-41 |
|      | Weather Pack.....   | 3-12 |      | Fuel Vapor Canister Hoses.....                   | 3-41 |
|      | Terminal Repair.....  | 3-12 | 3.4  | <b>DIRECT IGNITION SYSTEM</b> .....              | 3-43 |
|      | Wiring Connector Service.....   | 3-13 |      | On-Vehicle Service.....                          | 3-43 |
|      | Tools Needed to Service the System.....                                   | 3-14 |      | Direct Ignition System Assembly.....             | 3-43 |
|      | Wiring Harness Service.....   | 3-15 |      | Ignition Coil.....                               | 3-43 |
|      | Checking Terminal Contact.....  | 3-15 |      | Ignition Module.....                             | 3-43 |
|      |   |      |      | Crankshaft Sensor.....                           | 3-44 |
| 3.1  | <b>ELECTRONIC CONTROL MODULE AND SENSORS</b> .....                        | 3-18 | 3.9  | <b>INTAKE MANIFOLD HEATER</b> .....              | 3-45 |
|      | Electronic Control Module.....  | 3-18 |      | On-Vehicle Service.....                          | 3-45 |
|      | Engine Calibrator.....  | 3-20 | 4    | <b>SPECIFICATIONS</b> .....                      | 4-1  |
|      | Functional Check.....   | 3-20 |      | 1.7L Throttle Body Injection.....                | 4-1  |
|      | Coolant Temperature Sensor.....   | 3-21 | 5    | <b>TORQUE SPECIFICATIONS</b> .....               | 5-1  |
|      | Octane Adjustment Potentiometer.....                                      | 3-22 |      | 1.7L Throttle Body Injection.....                | 5-1  |
|      | Manifold Absolute Pressure Sensor.....                                    | 3-22 | 6    | <b>SPECIAL TOOLS</b> .....                       | 6-1  |
|      | Throttle Position Sensor.....   | 3-23 |      | 1.7L Throttle Body Injection.....                | 6-1  |
|      | Vehicle Speed Sensor.....   | 3-23 |      |  |      |
|      | Oxygen Sensor.....  | 3-24 |      |  |      |
|      | Intake Air Temperature Sensor.....  | 3-25 |      |  |      |

# **TURBONutter**

Lada Niva 4x4  
Service Manual  
Fuel Injection

This manual and a host of other wonderful Lada Niva documentation is available free of charge at:

<http://www.turbo-nutter.com>

You can do anything you like with this manual except sell it or otherwise make money from it.

While I can't stop you sticking it on your own website I would much prefer you linked to its original location on turbo-nutter.com

You use the information contained with this manual at you own risk. If you're not sure how to do something either don't do it or ask someone who knows about such things. The font of all Lada knowledge can be found at:

<http://www.lada.co.uk/forum>

For Lada parts, advice and general all round Lada wonderfulness these blokes aren't bad:

Lada UK Ltd  
Askew Rigg  
Troutbeck  
Penrith, Cumbria  
CA11 0SZ  
United Kingdom

T: +44 (0) 17 6877 9794  
F: +44 (0) 17 6877 9197  
E: [alan@lada.co.uk](mailto:alan@lada.co.uk)  
W: <http://www.lada.co.uk>

Lada Parts Australia P/L  
42 Aerodrome Road  
Caboolture  
Queensland  
4510  
Australia

T: +61 7 5495 5100  
F: +61 7 5495 5152  
E: [andy@ladaparts.com](mailto:andy@ladaparts.com)  
W: <http://www.ladaparts.com>

## 1. GENERAL DESCRIPTION AND SYSTEM OPERATION

The engine used in this vehicle is equipped with electronic fuel injection and uses an electronic control module to control exhaust emissions while maintaining excellent driveability and fuel economy. The electronic control module maintains a desired air/fuel ratio of 14.7 to 1.

In addition to fuel control, the electronic control module also controls ignition dwell and timing, idle speed, electric fuel pump, an instrument panel "Check Engine" light, and the air conditioning compressor clutch. Figure 1-1 contains a list of the various operating conditions sensed by the electronic control module on the left, and the various systems controlled on the right.

The electronic control module has a built-in diagnostic system that recognizes and identifies possible operational problems and alerts the driver by lighting the "Check Engine" light in the instrument panel. If the light comes "ON" while driving, it does not mean that the engine should be stopped immediately, but the cause of the light coming "ON" should be checked as soon as is reasonably possible. The electronic control module has built-in backup systems that in all but the most severe failures will allow the vehicle to operate in a near normal manner until repairs can be made.

The assembly line data link connector is used by the assembly plant for a computer check-out of the engine management system. The assembly line data link is located in the passenger compartment. This connector is used during servicing to help diagnose the engine management system. Refer to "Diagnosis," in Section "2" for further details.

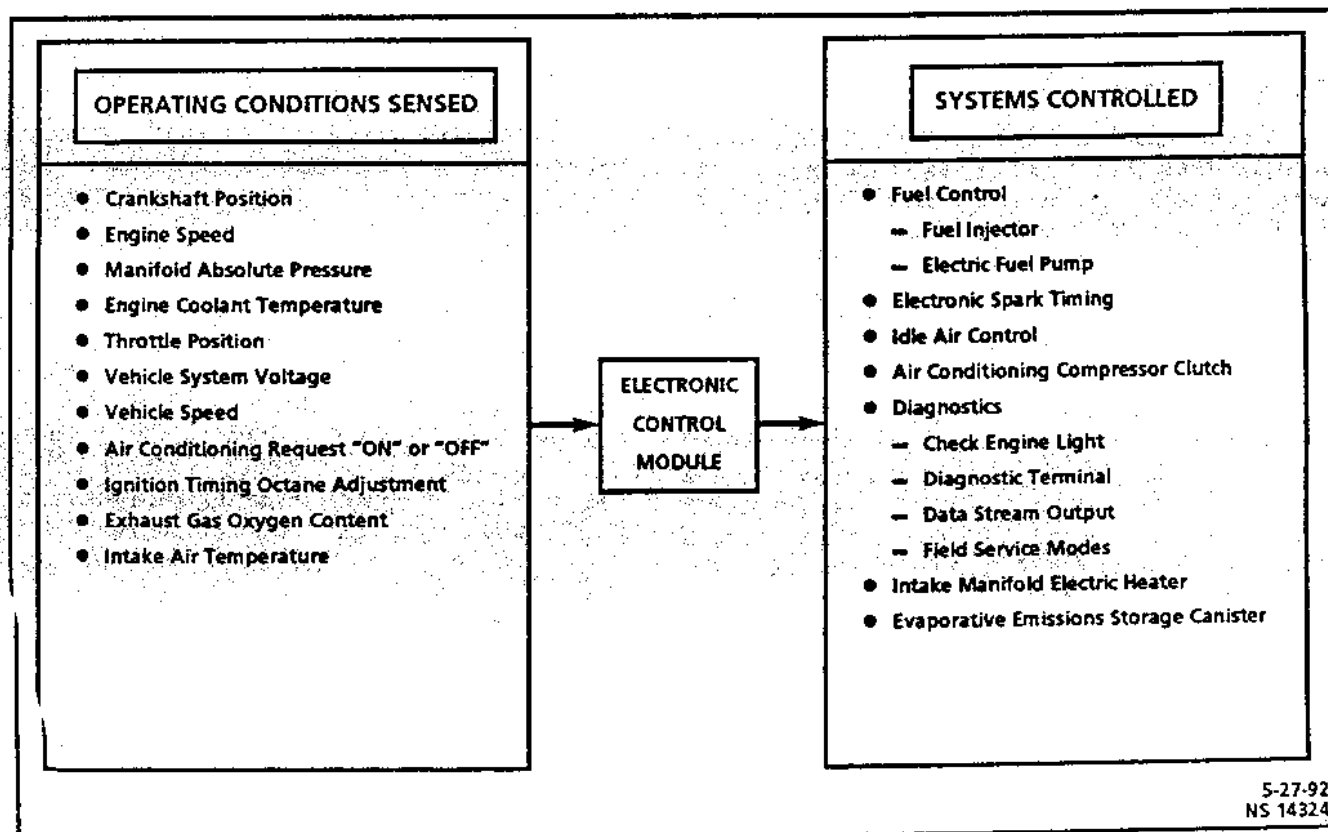

Figure 1-1 - Electronic Control Module Operating Conditions Sensed and Systems Controlled



### Air pollution, and harmful exhaust emissions

In the past, automobile manufacturers have used many methods to meet increasingly stringent air pollution standards. These methods have included crankcase ventilation systems, adjustments of engine compression, camshaft profile, ignition spark timing, and modifications to carburetion. While carburetors can be modified and adjusted to provide reasonable accuracy of the air/fuel mixture at some operating conditions, it is difficult for a carburetor to precisely control the mixture at all possible operating conditions of an engine. And over time, a carburetor may require maintenance, including careful, and precise adjustments.

While the methods listed above have been somewhat effective, there is a more effective method of reducing harmful exhaust emissions, while at the same time improving the overall operation of the engine. This method is to use a catalytic converter in the exhaust system, and equip the engine with an electronic fuel injection system.

An electronic fuel injection system is the best method of maintaining total control of the air/fuel mixture over all operating conditions. It requires no adjustments, and will maintain optimum catalytic converter efficiency over very long periods of time. As an added benefit, the electronic fuel injection system has no adverse effects on fuel economy, and actually improves engine responsiveness and overall vehicle driveability.

### Catalytic Converters

A catalytic converter has the ability to significantly reduce harmful exhaust emissions, if the engine combustion process is carefully controlled. This means that the air/fuel mixture being drawn into the engine must be very carefully and accurately metered, in order for the catalytic converter to reduce harmful exhaust emissions efficiently. These harmful exhaust emissions are hydrocarbons, carbon monoxide, and oxides of nitrogen.

A catalyst accelerates a chemical reaction without changing its own properties. The catalytic converter used in the throttle body fuel injection system is a "three-way" converter. It contains two oxidizing catalysts and a reducing catalyst, to accelerate a conversion process of hydrocarbons, carbon monoxide, and oxides of nitrogen into something less harmful.

The oxidizing catalysts are platinum and palladium. They add oxygen to the hydrocarbons and carbon monoxide in the exhaust, to convert hydrocarbons to water vapor and carbon monoxide to carbon dioxide.

The reducing catalyst is rhodium. It speeds up a chemical reaction by removing oxygen from the oxides of nitrogen, to convert oxides of nitrogen to harmless nitrogen, which makes up the major portion of the air we breathe.

Because the catalytic converter needs oxygen to convert hydrocarbons and carbon monoxide, and yet must remove the oxygen to convert oxides of nitrogen, a very careful balance of the air/fuel mixture going into the engine must be maintained.

Too much remaining oxygen in the exhaust after combustion (lean exhaust) makes it difficult for the catalytic converter to remove oxygen from the oxides of nitrogen. Too little remaining oxygen in the exhaust after combustion (rich exhaust) makes it difficult for the catalytic converter to add oxygen to the carbon monoxide and hydrocarbons. Only a careful balance of the air/fuel mixture will allow the catalytic converter to effectively convert all three pollutants.

The ideal air/fuel mixture for the most complete combustion of the air/fuel mixture, and the most efficient conversion by the catalytic converter of the three exhaust pollutants, is between 14.6 and 14.7 : 1 air/fuel ratio. This means 14.6–14.7 parts air to 1 part fuel.

Such precision metering of the air/fuel mixture is best performed by an electronic fuel injection system, utilizing a closed-loop feedback signal from an exhaust gas oxygen sensor to precisely adjust its own fuel delivery calculations.

If the engine is poorly maintained and/or there are high concentrations of unburned fuel in the exhaust gases, over a period of time the catalytic converter can become inoperative due to thermal stress as it attempts to oxidize the excess hydrocarbons. Another cause of catalytic converter failure is the use of leaded fuel. The lead in the fuel will quickly render the catalysts ineffective. If either thermal stress or continued use of leaded fuel occurs, the tiny passageways in the ceramic substrate of the converter can become damaged (restricted), causing excessive exhaust backpressure.

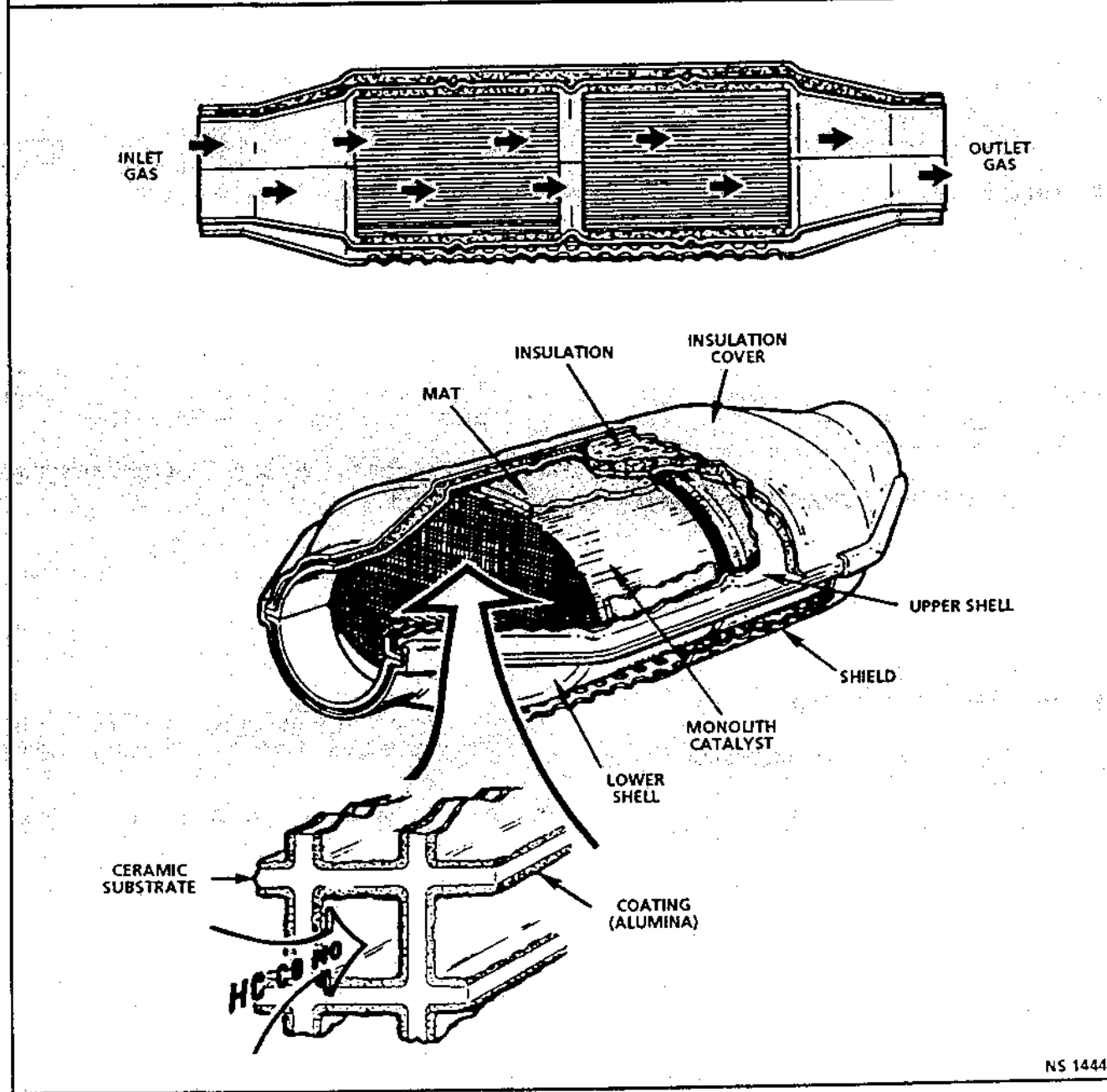
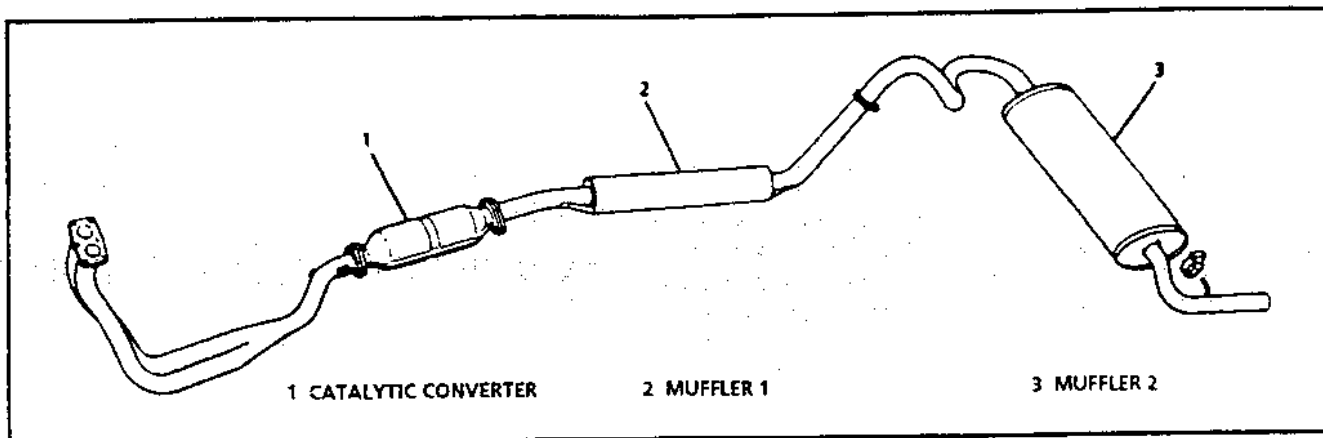

Catalytic Converter and Exhaust System

## 1-4 ENGINE MANAGEMENT SYSTEMS 1.7L THROTTLE BODY INJECTION

### GLOSSARY OF TERMS

Terms used in this manual are listed below in alphabetical order with an explanation.

**ABSOLUTE PRESSURE** - Uses a zero reference point of a total absolute vacuum. An absolute pressure gauge placed into an absolute vacuum would indicate "zero." If left unconnected in a room, the absolute pressure gauge would indicate the atmospheric pressure surrounding the gauge, approximately 100 kPa at sea level. This pressure reading would be a "barometric pressure" reading which will change at different altitudes or with various barometric pressure changes. When connected into an engine intake manifold, the absolute pressure gauge will indicate the "air pressure" in the intake manifold. With the engine stopped, this pressure reading will equal atmospheric pressure. When the engine is running it acts like a vacuum pump, and the intake manifold pressure will be less than the atmospheric pressure. This "engine running" pressure reading is dependent on throttle opening and engine speed.

**AIR/FUEL RATIO** - The amount of air compared to the amount of fuel in the air-fuel mixture. See also **STOICHIOMETRIC RATIO**.

**ANALOG SIGNAL** - An electrical signal that varies in voltage within a given range.

**ASSEMBLY LINE DATA LINK** - Used at the assembly plant to evaluate the engine management system, for service (to flash "Check Engine" light), use of Tech 1 diagnostic tool, and performing other system checks.

**ASSEMBLY LINE DATA LINK DATA STREAM** - An output of the electronic control module. This output is a digital computer-language signal used by assembly plant test equipment and the Tech 1 diagnostic tool. This signal is transmitted to the assembly line data link connector.

**BAROMETRIC PRESSURE** - Atmospheric pressure. May also be called BARO pressure.

**CARBON MONOXIDE** - One of the pollutants found in engine exhaust.

**CHECK ENGINE LIGHT** - Warning indicator with the outline of an engine, located in the instrument panel, and controlled by the electronic control module. Illuminated by the electronic control module when it detects a malfunction in the engine management system, or when the ignition is "ON" with the engine not running (bulb check).

**COOLANT TEMPERATURE SENSOR** - Device that senses the engine coolant temperature, and passes that information to the electronic control module.

**CURRENT OR AMPERAGE** - A measurement of the flow rate or amount of electricity. The rate of flow of electrons is similar to gallons of water per minute flowing in a water pipe.

**DIAGNOSTIC CODE** - See **SELF-DIAGNOSTIC CODE**.

**DIAGNOSTIC DISPLAY MODE** - An electronic control module mode of operation that is used to display stored codes on the "Check Engine" light. This mode is entered by grounding the assembly line data link terminal "B" when the ignition is "ON" and the ENGINE STOPPED - it is similar to the "Field Service" mode but with the engine not running.

**DIAGNOSTIC "TEST" TERMINAL** - "B" terminal of the assembly line data link connector, grounded to flash a trouble code on the "Check Engine" light.

**DIAGNOSTIC TOOL** - See Tech 1.

**DIGITAL SIGNAL** - An electrical signal that can only be either "ON" or "OFF."

**DIGITAL VOLTMETER** - Digital voltmeter with at least 10 million ohms per volt impedance—used for voltage and resistance measurement in electronic systems.

**DIODE** - An electrical device that restricts current flow in one direction.

**DIRECT IGNITION SYSTEM** - The direct ignition system does not use the conventional distributor and coil. This ignition system consists of an ignition module and crankshaft sensor in addition to the related connecting wires and the electronic control module. It is a very reliable and efficient system.

**DRIVER** - An electronic device, usually a power transistor, that operates like a switch; that is, it turns something "ON" or "OFF."

**ELECTRONIC CONTROL MODULE** - A metal cased box containing electronic circuitry which electrically monitors and controls air/fuel and emission systems on the engine management system, and turns "ON" the "Check Engine" light when a malfunction is detected in the system.

## ENGINE MANAGEMENT SYSTEMS 1.7L THROTTLE BODY INJECTION 1-5

**ELECTROMAGNETIC INTERFERENCE OR ELECTRICAL NOISE** - An unwanted signal interfering with another needed signal; like an electric razor upsets a television picture, or driving under high voltage power lines cause static noise in the AM radio in a vehicle.

**ELECTRONIC FUEL INJECTION** - Electronic control module control of fuel delivery, which in this case utilizes a throttle body injection unit.

**ELECTRONIC SPARK TIMING** - Electronic control module controlled timing of ignition spark.

**ENERGIZE/DE-ENERGIZE** - When current is passed through a coil (energized) such as a solenoid, a plunger is pulled or pushed. When the voltage to the solenoid is turned "OFF," (de-energized), a spring raises or lowers the plunger.

**ENGINE CALIBRATOR** - A plug-in memory unit that instructs the electronic control module how to operate for a particular vehicle.

**EVAPORATIVE EMISSIONS CONTROL SYSTEM** - Used to prevent gasoline vapors in the fuel tank from entering the atmosphere. Stores the vapors in a storage canister, located above the left front wheel well. The canister contains activated charcoal, and the vapors are "purged" by engine vacuum during certain operating conditions. This purging action is controlled by the electronic control module.

**FIELD SERVICE MODE** - An electronic control module mode of operation that is used during service. It is operational when the **ENGINE IS RUNNING** and the Assembly line data link diagnostic test terminal "B" is grounded.

**FUEL INJECTION** - Electronic control module fuel control using throttle body fuel injection.

**HARD FAIL** - A term used to indicate the electronic control module is presently detecting an existing malfunction, has turned "ON" the "Check Engine" light, and logged the malfunction code in memory.

**HIGH** - A voltage more than ground or 0. In digital signals, high is "ON" and low is "OFF."

**HIGH IMPEDANCE VOLTMETER** - Has high opposition to the flow of electrical current. Good for reading circuits with low current flow, such as found in electronic systems. Digital voltmeter meets these requirements while older analog "moving needle" meters do not.

**HYDROCARBONS** - One of the pollutants found in engine exhaust.

**IDLE AIR CONTROL** - Installed in the throttle body unit and controlled by the electronic control module to regulate idle air flow, and thus idle rotations per minute.

**IDEAL MIXTURE** - The air/fuel ratio which provides the best performance, while maintaining maximum conversion of exhaust emissions, typically 14.7/1 on Gasoline engines.

**INPUTS** - Information from sensors and switches used by the electronic control module to determine how to control its outputs.

**INTAKE AIR TEMPERATURE SENSOR** - The intake air temperature sensor is a thermistor located in the air cleaner housing. It monitors air temperature passing into the throttle body. The electronic control module uses this information in its fuel delivery calculations.

**INTERMITTENT** - Occurs now and then; not continuously. In electrical circuits, refers to occasional open, short, or ground.

**INSTRUMENT PANEL (I/P)** - Contains instrument gages and indicator lights to indicate performance of the vehicle.

**KILOMETER PER HOUR** - A metric unit measuring distance (1000 meters) in one hour.

**LITER** - A metric unit of capacity.

**LOW** - Electrically operates the same as a ground and may, or may not, be connected to chassis ground.

**MALFUNCTION CODE** - See **SELF-DIAGNOSTIC CODE**

**MANIFOLD ABSOLUTE PRESSURE SENSOR** - Reads intake manifold pressure changes, similar to a vacuum gauge reading manifold vacuum, with pressure readings reversed from a vacuum gauge. See **ABSOLUTE PRESSURE**.

**MERCURY** - A calibration material used as a standard for vacuum or pressure measurement.

**MODE** - A particular state of operation.

**NEWTON METERS (TORQUE)** - A metric unit which measures force.

**NORMALLY OPEN** - Switch contacts that are not connected, or not together, when no outside forces (temperature, pressure, position) are applied.

## 1-6 ENGINE MANAGEMENT SYSTEMS 1.7L THROTTLE BODY INJECTION

**NORMALLY CLOSED** - Switch contacts that are connected, or together, when no outside forces (temperature, pressure, position) are applied.

**NITROGEN, OXIDES OF** - One of the pollutants found in engine exhaust. Nitrogen that combines with oxygen to form oxides of nitrogen.

**OCTANE ADJUST POTENTIOMETER** - An ignition timing adjustment potentiometer which is used as an input signal by the electronic control module. This is a "dealer only" adjustment which requires use of the Tech 1 diagnostic tool, and is used to define a spark retard condition which allows for low octane fuel.

**OUTPUT** - Functions, typically solenoids and relays, that are controlled by the electronic control module.

**OXYGEN SENSOR** - Monitors the oxygen content of the exhaust gases and generates a voltage signal to the electronic control module.

**PORT FUEL INJECTION** - Injection is controlled by the electronic control module to supply the precise air/fuel ratio. Fuel is injected at each cylinder near the intake valve.

**PROGRAMMABLE READ ONLY MEMORY** - An electronic term used to describe the engine calibration unit, and a part of the engine calibrator.

**PULSE WIDTH MODULATED** - A digital signal turned "ON" and "OFF" for a percentage of available "ON-plus-OFF" cycle time, such as 30% "ON" and 70% "OFF" would be called a 30% "ON" pulse width modulated signal.

**QUAD DRIVER** - A "chip" device in the electronic control module, capable of operating four separate outputs. Outputs can be either "ON-OFF" or pulse width modulated.

**RESISTANCE** - The ability of a circuit to limit current flow; like a restriction in a water pipe.

**REVOLUTIONS PER MINUTE** - A measure of engine rotation speed.

**SCAN TOOL** - See Tech 1.

**SELF-DIAGNOSTIC CODE** - Also known as "trouble code," or "malfunction code." The electronic control module can detect malfunctions in the engine management system. If a malfunction occurs, the electronic control module turns "ON" the "Check Engine" light, and a two-digit code number will set in the electronic control module's memory.

A diagnostic code can be obtained from the electronic control module through the "Check Engine" light, or with the Tech 1 diagnostic tool. This code will indicate the area of the malfunction. Properly following the workshop manual diagnostic procedures for the engine management system will locate the source of the problem. *NOTE: Code 12 is NOT a trouble code, but does verify that the electronic control module's diagnostic ability is operational.* Code 12 means "no crankshaft reference signal," which is normal when the engine is not running.

**STOICHIOMETRIC RATIO** - The ideal air fuel ratio when all of the air and all of the fuel is burned in the cylinder. The stoichiometric ratio is the best compromise between a rich air-fuel ratio for best power, and a lean air-fuel ratio for best economy. Also called the Ideal Air-Fuel Ratio.

For Pure Gasoline vehicles the ideal air fuel ratio is 14.7/1.

**TACHOMETER** - A device for indicating speed for rotation.

**TECH 1 (ALSO CALLED TECH 1 SCAN TOOL OR TECH 1 DIAGNOSTIC TOOL)** - A hand-held diagnostic tool, containing a microprocessor to interpret the electronic control module's assembly line data link data stream. A display panel displays the electronic control module's input signals and output commands. The Tech 1 is CRUCIAL for diagnosis and servicing of the fuel injection system.

**THROTTLE BODY INJECTION UNIT** - Is controlled by the Electronic control module to supply precise air/fuel mixture into the intake manifold. The throttle body injection unit is a single point fuel injection unit. It contains one fuel injector centrally located above the throttle valve. The unit is mounted on the intake manifold and replaces the conventional carburetor. It also contains the fuel pressure regulator, throttle position sensor, and idle air control device which regulates idle speed.

**THROTTLE POSITION SENSOR** - Device that tells the electronic control module the current throttle position, and when it is moving, the rate of throttle opening/closing.

**TROUBLE CODE** - See SELF-DIAGNOSTIC CODE

**VACUUM, MANIFOLD** - Vacuum source is the engine.

**VACUUM, PORTED** - Vacuum source from a small "port" in the throttle body. With the throttle closed, there would be no vacuum measured, because the port is on the air cleaner side of the throttle blade, and is exposed to engine vacuum only after the throttle is open.

**VEHICLE IDENTIFICATION NUMBER** - Appears on a plate attached to the dash.

**VEHICLE SPEED SENSOR** - A "Hall Switch" device that sends signal pulses to the electronic control module to be interpreted as vehicle speed (road speed).

**VOLT** - A measurement of electrical pressure.

**VOLTAGE** - The pressure of force pushing the current in a circuit; like pressure in a water pipe.

**WIDE OPEN THROTTLE** - Refers to the throttle valve or accelerator pedal when fully open or depressed.

## 1.1 ELECTRONIC CONTROL MODULE AND SENSORS

### ELECTRONIC CONTROL MODULE

The electronic control module (Figures 1.1-1 and 1.1-2), located behind the front left footspace trim panel, is the control center of the fuel injection system. It constantly monitors information from various sensors, and controls the systems that affect exhaust emissions and vehicle performance. The electronic control module performs the diagnostic function of the system. It can recognize operational problems, alert the driver through a "Check Engine" light, and store a code(s) which identifies problem areas to aid the technician in making repairs. See "Diagnosis," Section "2" for more information on using the diagnostic functions of the electronic control module.

The electronic control module supplies either 5, 8, or 12 volt signal voltages to various sensors or switches. This is done through resistances in the electronic control module which are so high in value that a test light will not light when connected to the circuit. In most cases, an ordinary shop voltmeter will not give an accurate reading because the meter's internal resistance is too low. *A 10 Million Ohm input impedance digital voltmeter is required to assure accurate voltage readings.* See "Special Tools," Section "6."

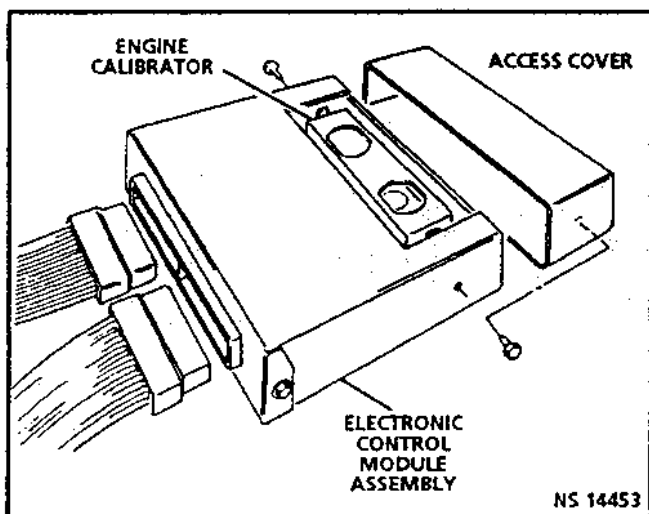

Figure 1.1-1 - Electronic Control Module

### ELECTRONIC CONTROL MODULE FUNCTION

The electronic control module controls output circuits such as the fuel injector, electronic spark timing system, idle air control, and various relays by controlling the ground circuit through transistors in the electronic control module. The only exception to this is the fuel system relay control circuit. The fuel system relay is the only electronic control module-controlled circuit where the electronic control module controls the +12 volts sent to the coil of the relay. The ground side of the fuel system relay coil is connected to engine ground.

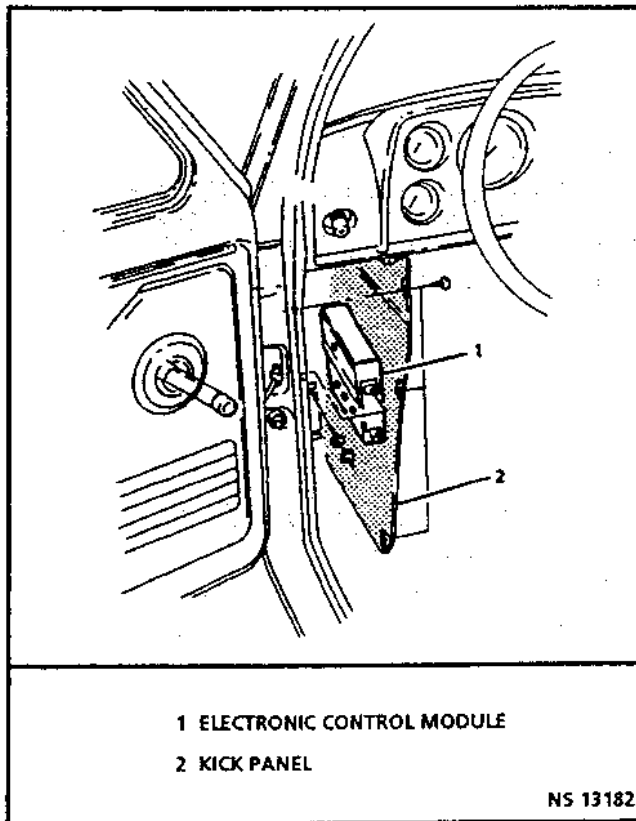

Figure 1.1-2 - Electronic Control Module Location

## ENGINE CALIBRATOR

To allow one model of electronic control module to be used for different vehicles, a device called an "Engine Calibrator" unit is used (see Figure 1.1-3).

The engine calibrator is located inside the electronic control module and has information on the vehicle's weight, engine, transmission, axle ratio and several other factors. While one electronic control module part number may be used by different vehicles, an engine calibrator is specific. For this reason, it is very important to check the latest parts catalog and Technical Information Bulletin for the correct part number when replacing an engine calibrator.

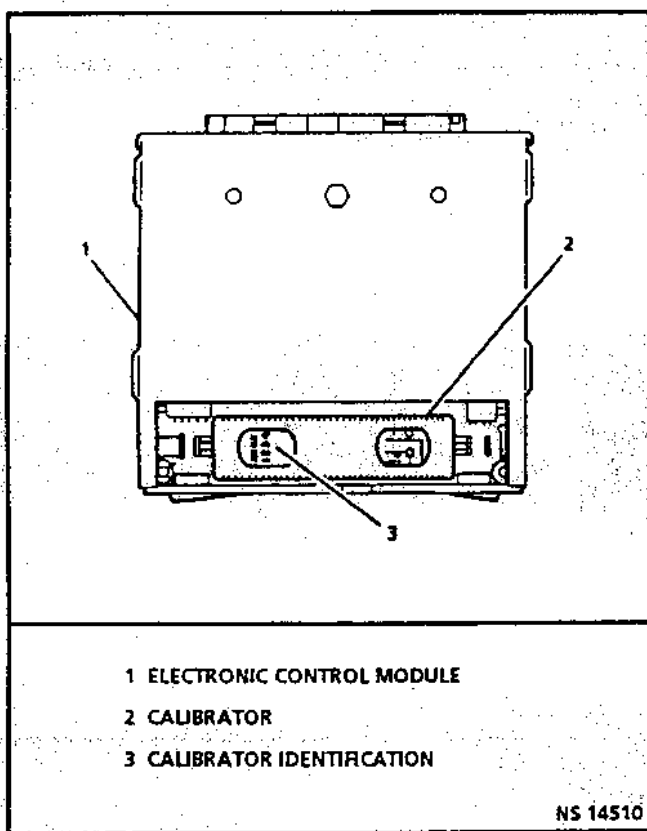

Figure 1.1-3 - Engine Calibrator

## MEMORY

There are three types of memory storage within the electronic control module: Read only memory, random access memory, and programmable read only memory.

### Read Only Memory

Read only memory is a permanent memory that is contained within the engine calibrator assembly, which is removable from the electronic control module. The read only memory contains the overall computer program, called "control algorithms" and is the set of operating instructions. Because it contains the control algorithms, the electronic control module cannot function without the calibrator installed.

Once the read only memory is programmed, it cannot be altered. The read only memory is nonvolatile, and does not need power to be retained.

### Random Access Memory

Random Access Memory is the "scratch pad" portion of the microprocessor, which is located on the circuit board of the electronic control module. Random access memory is generally used to calculate and temporarily store values that will be used in other calculations. The microprocessor can write into, or read from this memory as needed. This memory is volatile and needs a constant supply of voltage to be retained. If the voltage is lost, any stored trouble codes and calculated values are erased.

### Programmable Read Only Memory

Programmable read only memory contains the different engine calibration information that is specific to vehicle model, and emission regulations to be satisfied. The programmable read only memory is only read, or used, by the electronic control module. The programmable read only memory is nonvolatile, and does not need power to be retained.

The programmable read only memory is contained within the engine calibrator assembly and is removable from the electronic control module. The engine calibrator should be retained with the vehicle following electronic control module replacement.



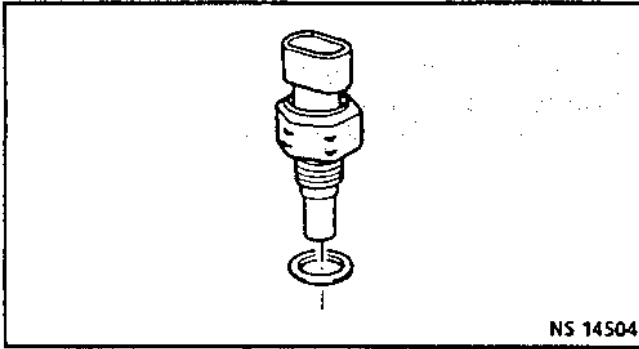

Figure 1.1-4 - Coolant Temperature Sensor

**INFORMATION SENSORS**

**Coolant Temperature Sensor**  
*Figures 1.1-4 and 1.1-5*

The coolant temperature sensor is a thermistor (a resistor which changes resistance based on temperature) mounted in the engine coolant stream. The thermistor inside the sensor is a "negative temperature coefficient" thermistor. That is, its resistance goes down as it gets hotter. High temperature causes low resistance (70 ohms at 130°C), while low coolant temperature produces a high resistance (100,700 ohms at -40°C).

The electronic control module supplies a 5 volt signal to the coolant temperature sensor through a fixed value resistor inside the electronic control module. By measuring the voltage drop across the variable resistance sensor, the electronic control module calculates the engine coolant temperature. The voltage will be high when the engine is cold, and low when the engine is hot. Engine coolant temperature affects most systems the electronic control module controls.

If a problem occurs in the coolant temperature sensor circuits, after a period of time the electronic control module will store a code in its memory and turn on the "Check Engine" light, indicating there is a problem. If this occurs, the electronic control module will calculate a "substitute" coolant temperature, based on either the signal from the intake air temperature sensor, or a substitute value stored in the electronic control module's memory.

A failure in the coolant temperature sensor circuits should set either a Code 14 or 15. Remember, these codes indicate a failure in the circuit, so proper use of the diagnostic chart will lead to either repairing a wiring problem or replacing the sensor to properly repair a problem.

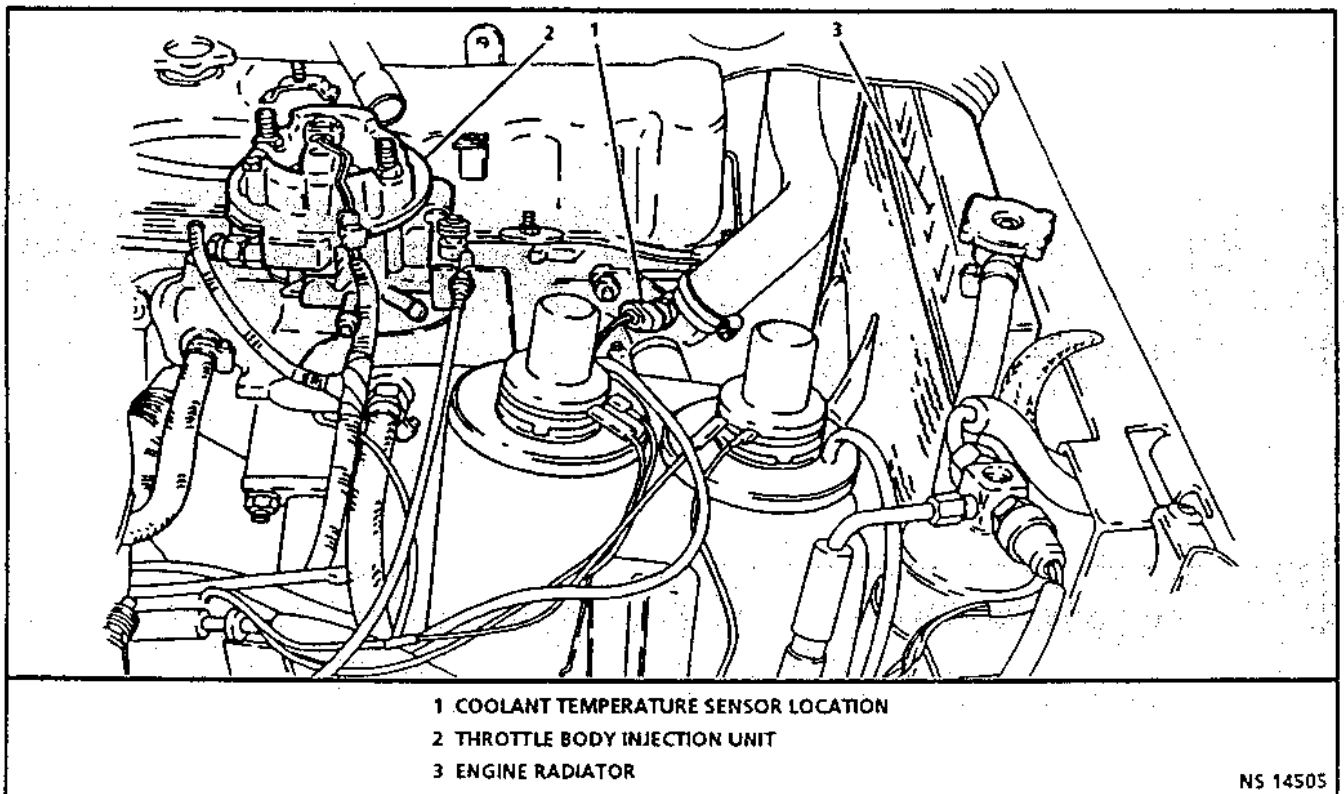

- 1 COOLANT TEMPERATURE SENSOR LOCATION
- 2 THROTTLE BODY INJECTION UNIT
- 3 ENGINE RADIATOR

NS 14505

Figure 1.1-5 - Coolant Temperature Sensor Location View

**Intake Air Temperature Sensor**  
**Figures 1.1-6 and 1.1-7**

The intake air temperature sensor is a thermistor (a resistor which changes value based on temperature) mounted in the bottom of the air cleaner, on the 1.7L engine. The thermistor inside the sensor is a "negative temperature coefficient" thermistor. That is, its resistance goes down as it gets hotter. High temperature causes low resistance (70 ohms at 130°C), while low air temperature produces a high resistance (100,700 ohms at -40°C).

The electronic control module supplies a 5 volt signal to the intake air temperature sensor through a fixed value resistor inside the electronic control module. By measuring the voltage drop across the variable resistance sensor, the electronic control module calculates the intake air temperature. The voltage will be high when the air is cold, and low when the air is hot.

Intake air temperature affects most systems the electronic control module controls.

If a problem occurs in the intake air temperature sensor circuits, after a period of time the electronic control module will store a code in its memory and turn on the "Check Engine" light, indicating there is a problem.

If this occurs, the electronic control module will calculate a "substitute" intake air temperature, based on either the signal from the coolant temperature sensor, or a substitute value stored in the electronic control module's memory.

A failure in the intake air temperature sensor circuits should set either a Code 23 or 25. Remember, these codes indicate a failure in the circuit, so proper use of the diagnostic chart will lead to either repairing a wiring problem or replacing the sensor, to properly repair a problem.

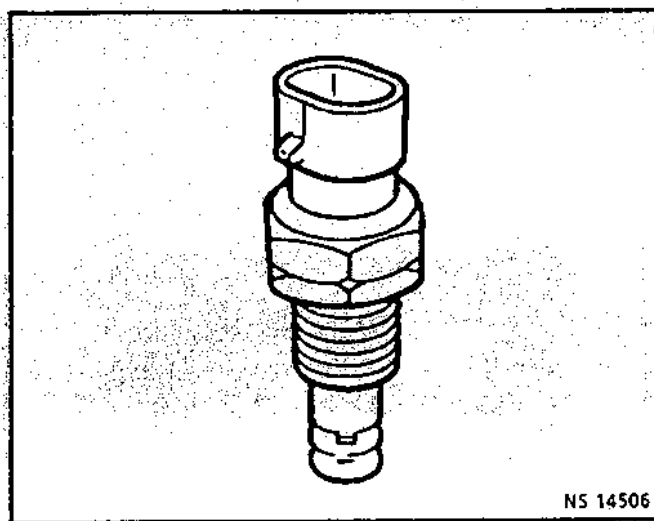
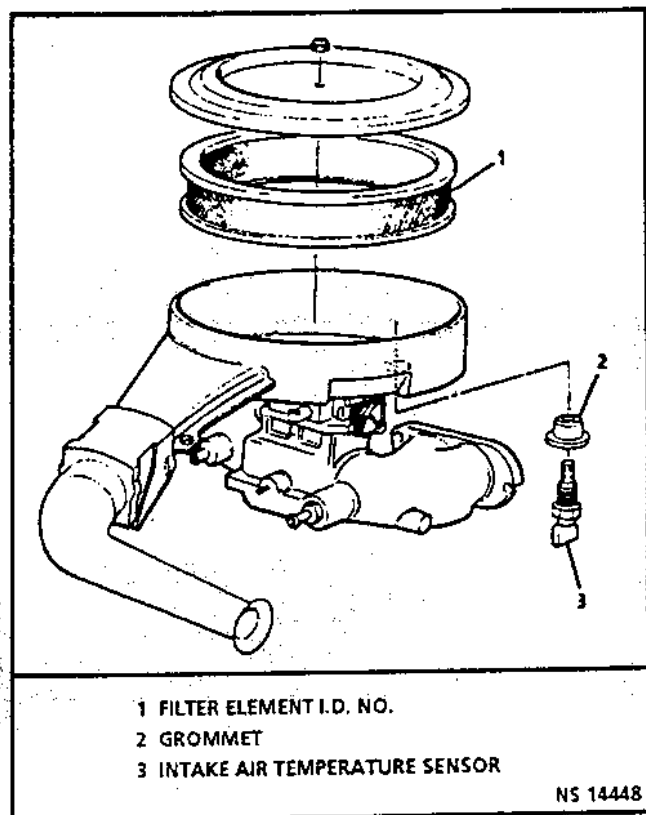

Figure 1.1-6 - Intake Air Temperature Sensor



- 1 FILTER ELEMENT I.D. NO.
- 2 GROMMET
- 3 INTAKE AIR TEMPERATURE SENSOR

Figure 1.1-7 - Intake Air Temperature Sensor Location View

**Manifold Absolute Pressure Sensor**  
**Figures 1.1-8 and 1.1-9**

To understand this sensor's operation, it is first required to understand the principle of absolute pressure measurement.

Most pressure gauges, when not connected to anything, indicate a "zero" reading. However, there is actually an atmospheric pressure surrounding the gauge. If an *absolute* pressure gauge is observed when not connected to anything, its reading would be about 100 kPa, or 1 bar, at sea level. That is because an absolute pressure gauge's "zero" point is an absolute vacuum, or the total absence of any pressure.

To further this explanation, absolute pressure measurement uses the zero reference point of a total absolute vacuum. An absolute pressure gauge would read "zero" only when placed into a vacuum chamber evacuated to an absolute, total vacuum. Any "pressure" above this absolute vacuum reference point will indicate a positive pressure. If left unconnected in a room, the absolute pressure gauge would indicate the atmospheric pressure surrounding the gauge, approximately 100 kPa at sea level. This pressure reading would be a "barometric" pressure reading which will change at different altitudes or with changes in barometric pressure.

When connected into an engine's intake manifold, the absolute pressure gauge will indicate the absolute pressure inside the manifold. With the engine stopped, this pressure reading will equal atmospheric pressure. With the engine running, its pumping action acts like a vacuum pump, and the intake manifold pressure will be less than atmospheric pressure. This "engine running" pressure reading is dependent on throttle opening and engine speed.

By using an absolute pressure gauge, the electronic control module can monitor for atmospheric pressure changes that normally occur with barometric pressure changes and/or changes in altitude. This "barometric" pressure is measured when the ignition is first turned "ON," before the engine begins cranking. The electronic control module can also "update" this barometric pressure reading during engine operation, when the throttle is nearly wide open at low engine speed.

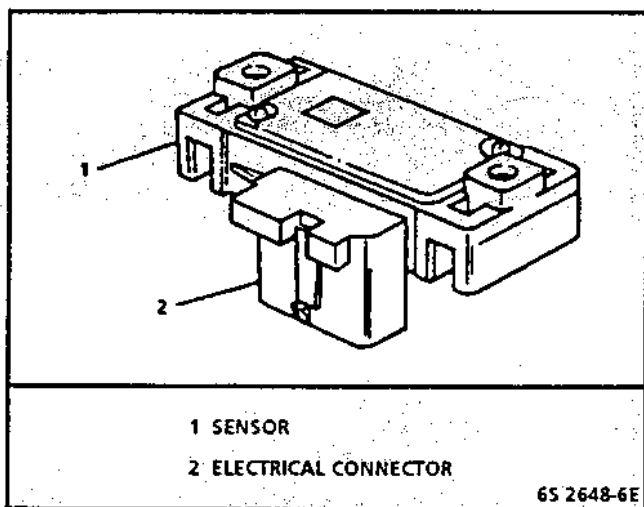

Figure 1.1-8 - Manifold Absolute Pressure Sensor

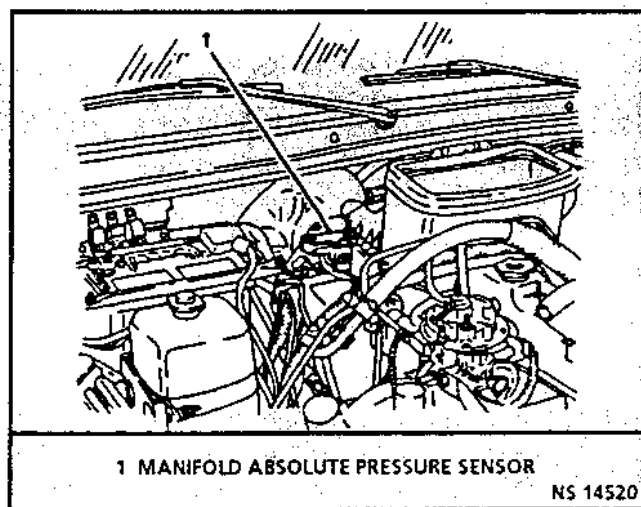

Figure 1.1-9 - Manifold Absolute Pressure Sensor Location View

The manifold absolute pressure sensor (Figure 1.1-8 and 1.1-9), is a pressure transducer that measures the changes in the intake manifold pressure. A small hose connecting the sensor to the intake manifold (or throttle body) allows the sensor to measure the absolute pressure inside the manifold. The pressure changes as a result of engine load and speed change, and the manifold absolute pressure sensor converts this to a voltage output signal.

The electronic control module sends a 5 volt reference voltage to the manifold absolute pressure sensor. As the manifold pressure changes, the 0-5 (zero to five) volt output signal of the sensor also changes in direct relation to the pressure.

A closed throttle on engine coastdown would produce a relatively low manifold absolute pressure output voltage, while a wide-open throttle would produce a high manifold absolute pressure output voltage. This high output voltage is produced because when the throttle is wide open, the pressure inside the manifold is nearly the same as atmospheric pressure.

By monitoring the sensor's output signal, the electronic control module calculates the manifold pressure. A higher pressure requires more fuel, while a lower pressure requires less fuel.

The electronic control module uses the manifold absolute pressure sensor signal as one of its most important input signals to control fuel delivery and ignition timing.

If a problem occurs in the manifold absolute pressure sensor circuits, after a period of time the electronic control module will store a code in its memory and turn on the "Check Engine" light, indicating there is a problem. If this occurs, the electronic control module will calculate a "substitute" manifold pressure, based on engine speed and throttle opening.

A failure in the manifold absolute pressure sensor circuits should set either a Code 33 or 34. Remember, these codes indicate a failure in the *circuit*, so proper use of the diagnostic chart will lead to either repairing a wiring problem or replacing the sensor, to properly repair a problem.

The table below shows the relationship of absolute pressure values to the sensor's output signal.

|     |                                   |     |     |     |     |     |     |     |     |     |                 |
|-----|-----------------------------------|-----|-----|-----|-----|-----|-----|-----|-----|-----|-----------------|
|     | Atmospheric pressure at sea level |     |     |     |     |     |     |     |     |     |                 |
|     |                                   |     |     |     |     |     |     |     |     |     | Absolute vacuum |
| BAR | 1.0                               | 0.9 | 0.8 | 0.7 | 0.6 | 0.5 | 0.4 | 0.3 | 0.2 | 0.1 | 0               |
| kPa | 100                               | 90  | 80  | 70  | 60  | 50  | 40  | 30  | 20  | 10  | 0               |
| V   | 4.9                               | 4.4 | 3.8 | 3.3 | 2.7 | 2.2 | 1.7 | 1.1 | 0.6 | 0.3 | 0.3             |
|     | Sensor output signal voltage      |     |     |     |     |     |     |     |     |     |                 |

Absolute Pressure Values to Sensors Output Signals Relationship Table

5-11-92  
NS 14975

**Throttle Position Sensor**  
**Figures 1.1-10 and 1.1-11**

The throttle position sensor is mounted on the side of the throttle body opposite the throttle lever assembly. Its function is to sense the current throttle valve position and relay that information to the electronic control module. Knowledge of throttle position is needed by the electronic control module to calculate the injector control signals (pulses). Should the throttle position sensor sense a wide open throttle, a voltage signal indicating this is sent to the electronic control module. The electronic control module will then widen the injector pulses, permitting increased fuel flow.

As the throttle valve rotates in response to movement of the accelerator pedal, the throttle shaft transfers this rotational movement to the throttle position sensor. When this occurs, the throttle position sensor output voltage changes. The electronic control module will use a rapidly increasing throttle position sensor signal voltage as an indication of increased fuel requirements, signaling the electronic control module to add extra injector control pulses. This simulates an accelerator pump in a carburetor.

The sensor is a potentiometer type of resistor, with one end connected to a 5 volt reference voltage from the electronic control module, and the other end to electronic control module ground. A third wire connects from a movable contact in the throttle position sensor to the electronic control module, allowing the electronic control module to measure the signal voltage from the throttle position sensor.

As the throttle is moved (accelerator pedal moved), the output signal from the movable contact inside the throttle position sensor changes. At a closed throttle position, the output of the throttle position sensor is below 1.25 volts. As the throttle valve opens, the output increases so that at a wide-open throttle position, the output voltage should be above 4 volts.

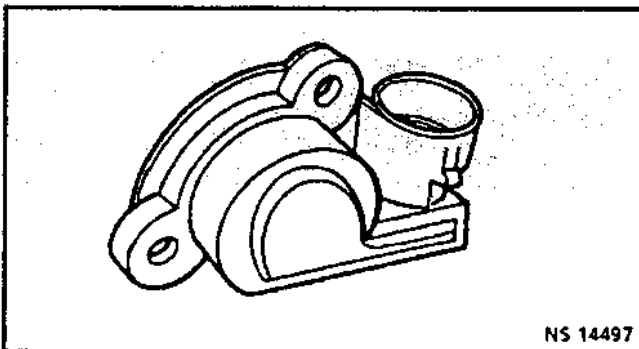

Figure 1.1-10 - Throttle Position Sensor

By monitoring the output voltage from the throttle position sensor, the electronic control module can determine the present throttle valve angle (driver demand). By monitoring for a *changing* voltage, the electronic control module can determine if the throttle valve is either opening or closing. A broken or loose throttle position sensor can cause intermittent bursts of fuel from the injector, and an unstable idle, because the electronic control module would calculate that the throttle is moving.

If a problem occurs in the throttle position sensor circuits, after a period of time the electronic control module will store a code in its memory and turn on the "Check Engine" light, indicating there is a problem. If this occurs, the electronic control module will calculate a "substitute" throttle position, based on engine speed.

A failure in the throttle position sensor circuits should set either a Code 21 or 22. Remember, these codes indicate a failure in the *circuit*, so proper use of the diagnostic chart will lead to either repairing a wiring problem or replacing the sensor, to properly repair a problem.

The throttle position sensor is not adjustable. The electronic control module uses the lowest signal voltage reading at idle for the zero reading (0% throttle), so no adjustment is necessary.

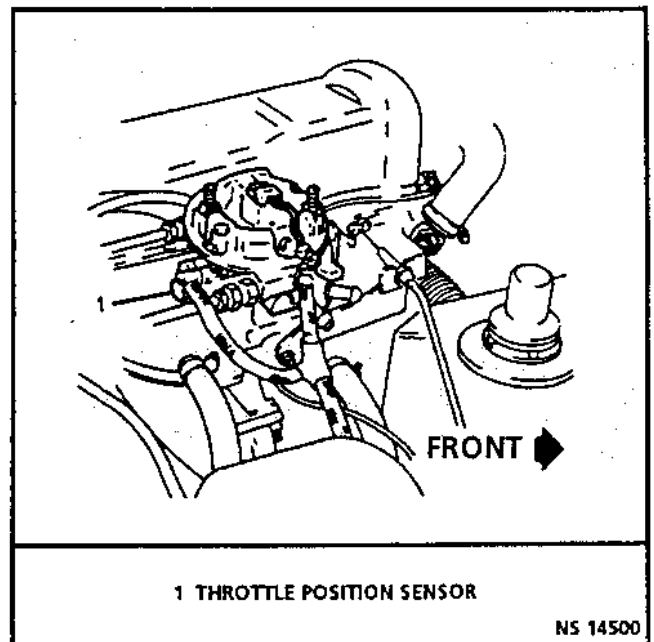

Figure 1.1-11 - Throttle Position Sensor Location View

**Oxygen Sensor (Electrically Heated)**  
**Figures 1.1-12 and 1.1-13**

For the most efficient emissions control, the best air/fuel mixture for a gasoline fueled engine is 14.6–14.7:1. This is called the “stoichiometric” ratio. With this combination of air and fuel, the catalytic converter is very efficient at reducing amounts of hydrocarbons, carbon monoxide, and oxides of nitrogen coming out of the engine’s exhaust. In order to keep the exhaust gases optimized so that the catalytic converter is in its most efficient operating range, a closed loop fuel control system is used.

The electronic control module initially calculates the fuel injector pulsewidth from other input signals, such as manifold absolute pressure, engine speed and coolant temperature, intake air temperature, and so on. After the fuel is injected into the engine, the exhaust gas oxygen sensor signal can be used to adjust or correct the fuel injector pulsewidth calculations.

The exhaust gas oxygen sensor is the key to “Closed-Loop” fuel control. This sensor is what allows the fuel injection control system to give a “Closed Loop” “feedback” signal to the electronic control module, as to how accurate its fuel injector pulsewidth calculations were. The electronic control module uses information from the oxygen sensor to precisely fine-tune its fuel injector pulsewidth calculations, based on the unused, “left-over” oxygen content in the exhaust.

The oxygen content in the exhaust reacts with the oxygen sensor to produce a voltage output, similar to a variable-voltage battery. This signal voltage could be thought of like a type of gauge, ranging from approximately 0.1 volt (high oxygen content - lean exhaust) to 0.9 volt (low oxygen content - rich exhaust).

Because the sensor acts like a gauge, it is only indicating how rich or lean the exhaust is. The sensor does not cause things to happen, it only indicates what has already happened.

The sensor is mounted in the exhaust manifold, with the sensing portion exposed to the exhaust gas stream. When the sensor has reached an operating temperature of more than 360°C, it acts as a voltage generator, producing a rapidly changing voltage of between 10 - 1000 millivolts. This voltage output is dependent on the oxygen content in the exhaust gas, as compared to the sensor’s atmospheric oxygen reference cavity. This reference cavity is exposed to the atmosphere through a small “vent” hole located under the sensor’s external metal vent cover.

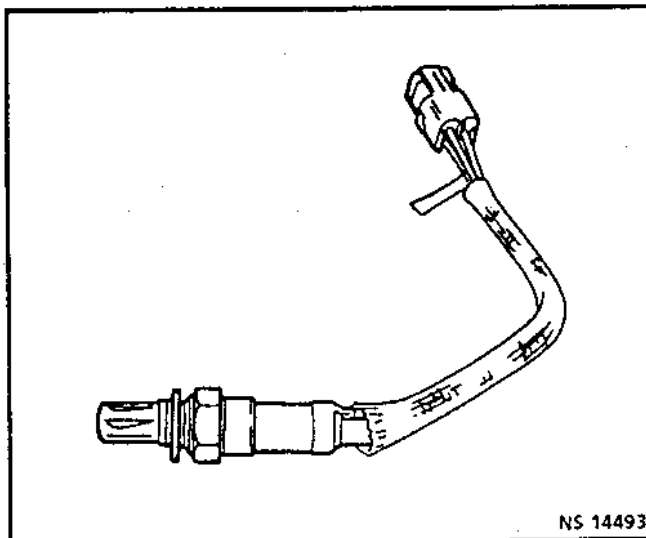

Figure 1.1-12 - Oxygen Sensor

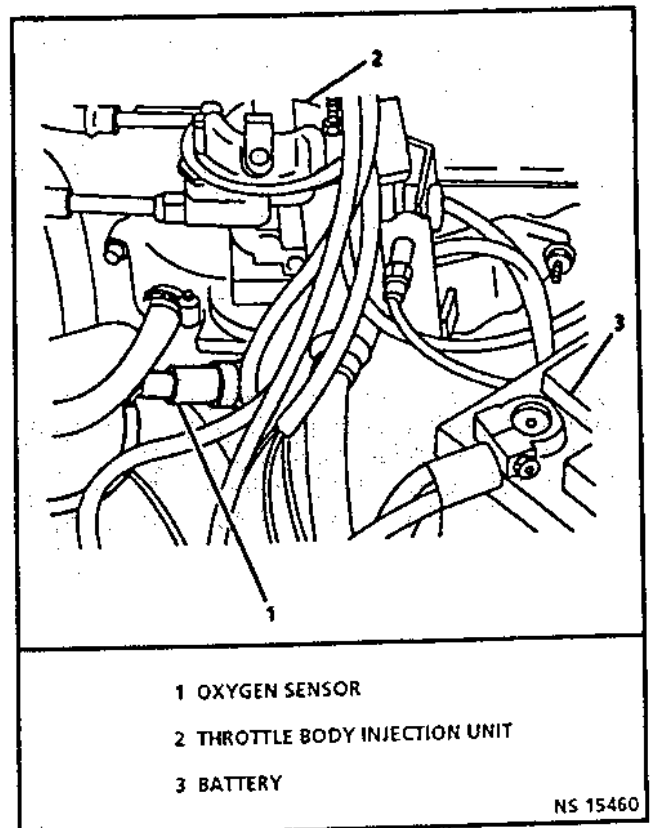

Figure 1.1-13 - Oxygen Sensor Location View

## 1-16 ENGINE MANAGEMENT SYSTEMS 1.7L THROTTLE BODY INJECTION

(Refer to Following Page for Additional Information When Reading Text Below)

When the sensor is cold, it produces either no voltage, or an unusable, slowly changing one. Also when cold, its internal electrical resistance is extremely high—many million ohms.

Because the sensor must be at least 360°C to operate effectively, it is equipped with an internal electric heating element to quickly heat the sensor after starting the engine. This heating element is powered from the vehicle's electrical system, any time the ignition is "ON."

The electronic control module always supplies a steady 450 millivolt, very low current "reference" voltage to the oxygen sensor circuit. When the sensor is cold and not producing any voltage, the electronic control module "sees" only this steady reference voltage. As the sensor begins heating and the engine is running, its internal resistance decreases and it begins producing a rapidly changing voltage that will overshadow the electronic control module-supplied steady reference voltage. When the electronic control module "sees" the changing voltage, it knows the sensor is hot and its output is ready to be used for the "fine-tuning" job. The electronic control module monitors the "changing," or going above and below a mid-range voltage band (approximately 300–600 millivolts), to help decide when to operate in the closed-loop mode. The Tech 1 diagnostic tool can display this ready status as "OXY-GEN SENSOR READY—NO / YES."

When the fuel system is correctly operating in the closed-loop mode, the sensor voltage output is rapidly changing several times per second, going above and below a rich/lean "switch point."

### Oxygen Sensor Poisoning

Oxygen sensors can be poisoned by either the use of leaded fuel, or assembling the engine parts with room temperature vulcanizing gasket sealer containing high amounts of high-volatility silicon. If the silicon volatility of a gasket sealer is very high, the silicon vapors will be drawn into the crankcase ventilation system, and introduced into the combustion process. These two elements, lead and silicon, can render the oxygen sensor inoperative over a period of time.

If the oxygen sensor circuitry has an open sensor signal circuit or ground circuit, or a defective, contaminated, or cold sensor, it could cause the signal voltage to stay within a 350–550 millivolt band too long, keeping the fuel control system in open-loop and storing a Code 13.

If the electronic control module receives a signal voltage indicating the exhaust gases have been lean for a long time, a Code 44 will store in the memory. One cause of a lean exhaust indication could include air leaks in the exhaust manifold or gasket, or low fuel pressure. A *false* indication of a lean exhaust could also include a grounded signal circuit between the oxygen sensor and the electronic control module.

If the electronic control module receives a signal voltage indicating the exhaust gases have been rich for a long time, a Code 45 will store in the memory. One cause of a rich exhaust indication could include high fuel pressure. A *false* indication of a rich exhaust could also include a signal circuit between the oxygen sensor and the electronic control module that has somehow become connected to another voltage source.

Any of the Codes 13, 44, or 45 will cause the fuel control system to remain in, or revert to, open loop operation.

# ENGINE MANAGEMENT SYSTEMS 1.7L THROTTLE BODY INJECTION 1-17

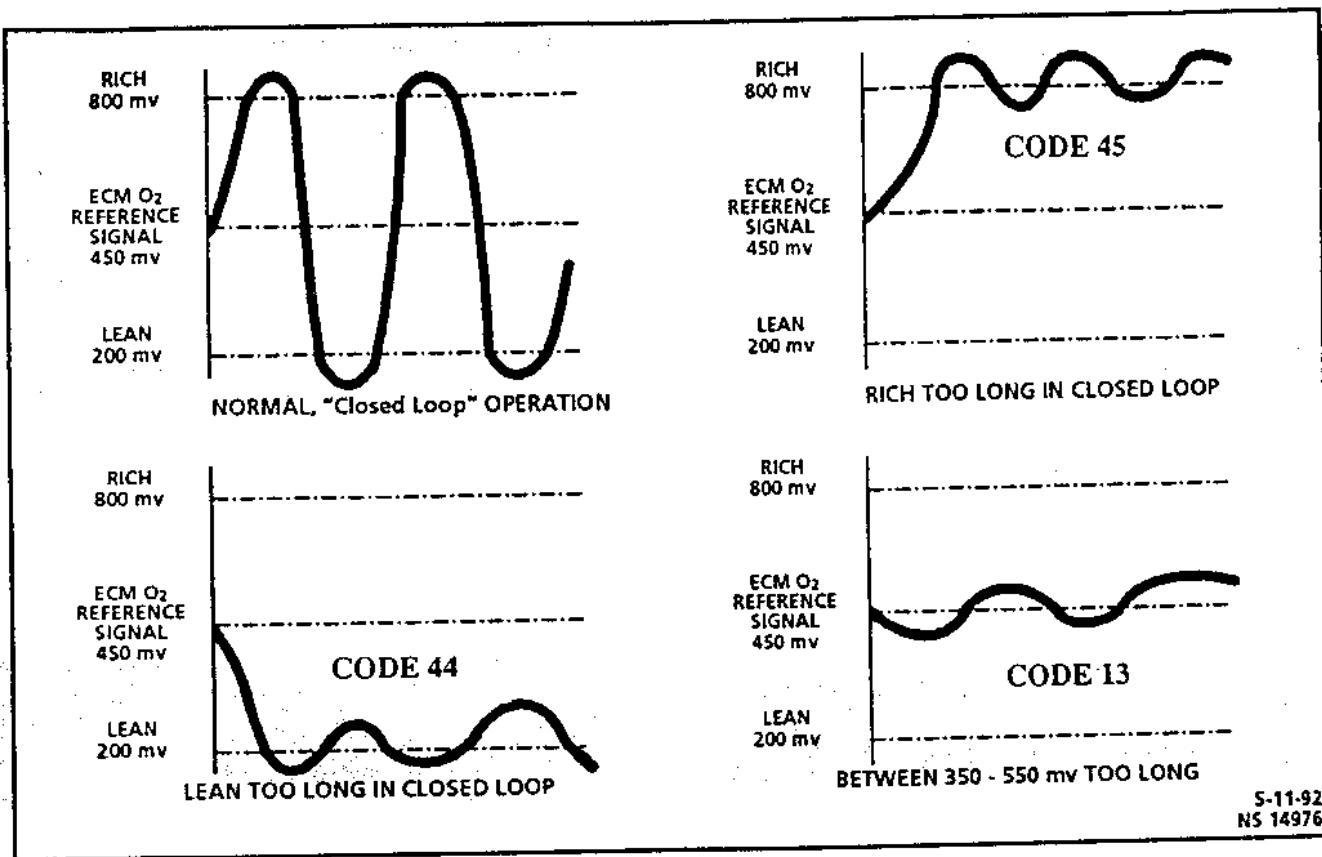

Oxygen Sensor Voltage Curves

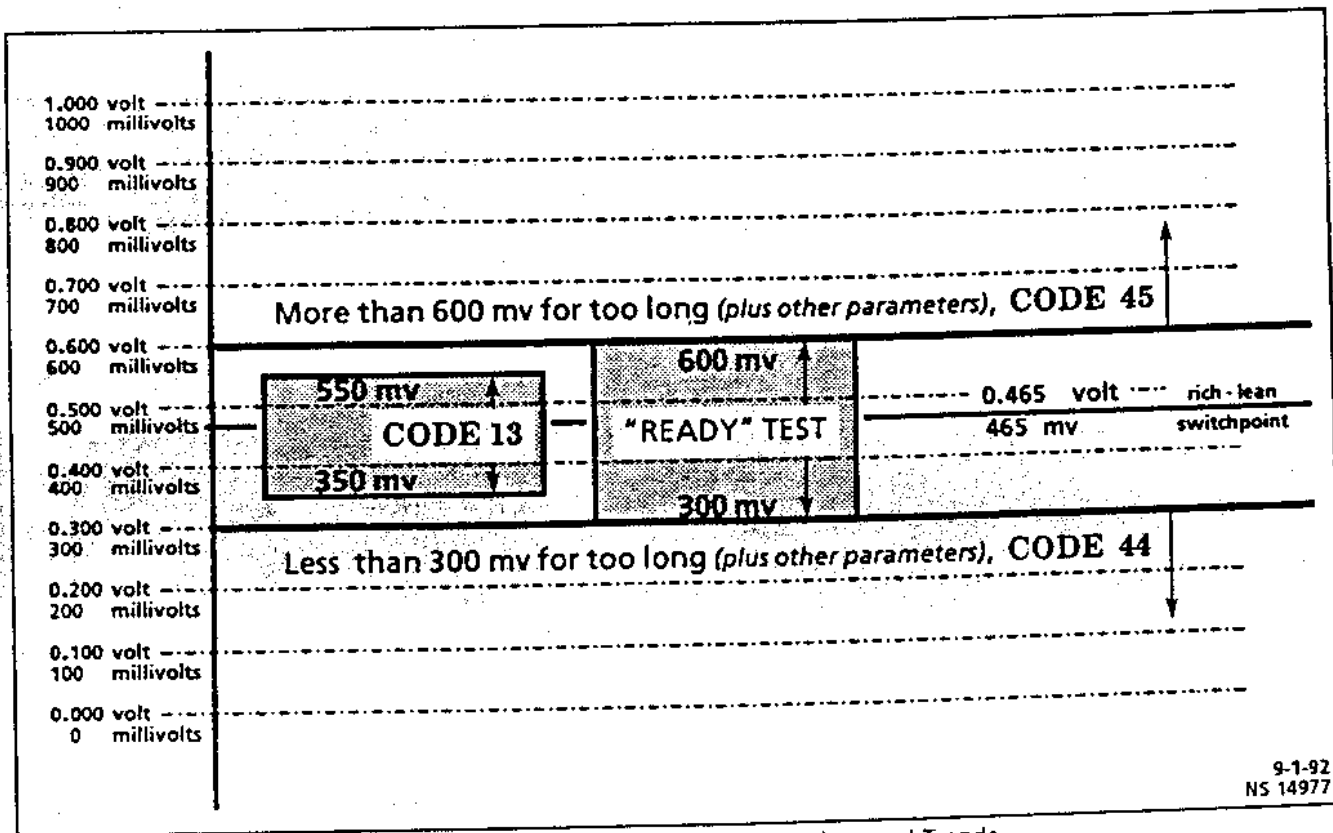

Normal Oxygen Sensor Voltages, and Abnormal Trends



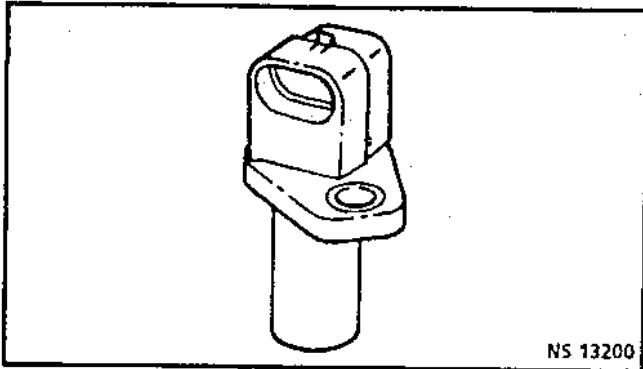

Figure 1.1-14 - Crankshaft Sensor

**Crankshaft Position Reference Signal**  
**Figures 1.1-14 and 1.1-15**

The ignition system sends this signal to the electronic control module to tell it engine speed and crankshaft position. This signal is a repeating series of low voltage electrical pulses generated by the ignition module.

The electronic control module initiates fuel injector pulses based on the crankshaft reference signal pulses.

If a problem occurs in the crankshaft reference signal circuit from the ignition module to the electronic control module, the engine will not run. The electronic control module must receive this signal to initiate any fuel injector pulses. If the signal is absent, no fuel injector pulses will be sent to the injector. Proper diagnosis of this problem is fully explained in Section 2 of this manual, titled "Diagnostics." As explained in Section 2, all system diagnosis begins with the "Diagnostic Circuit Check."

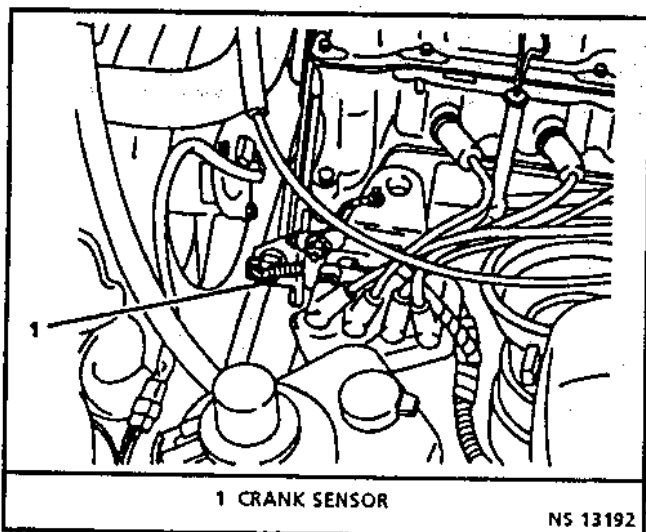

Figure 1.1-15 - Crankshaft Sensor Location View

**Vehicle Speed Sensor**  
**Figures 1.1-16 and 1.1-17**

The vehicle speed sensor is a pulse type input that informs the electronic control module at what road speed the vehicle is being driven. The vehicle speed sensor system uses a Hall Switch to send electrical pulses to the electronic control module. The sensor is mounted at the output shaft of the transfer gear case to produce a frequency proportional to the speed of the drive wheels. This sensor assists in controlling the idle air control.

If a problem occurs in the vehicle speed sensor circuits, after a period of time the electronic control module will store a Code 24 in its memory, and turn "ON" the "Check Engine" light, indicating there is a problem. Remember, this code indicates a failure in the *circuit*, so proper use of the diagnostic chart will lead to either repairing a wiring problem or replacing the sensor to properly repair a problem.

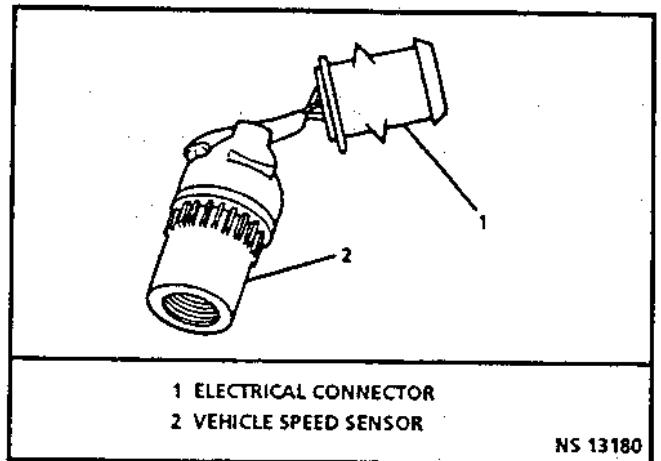

Figure 1.1-16 - Vehicle Speed Sensor

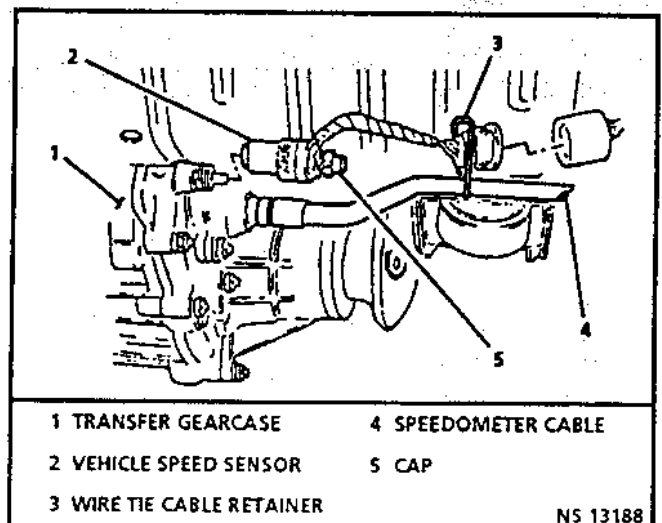

Figure 1.1-17 - Vehicle Speed Sensor Location View

**OCTANE ADJUSTMENT****Figures 1.1-18 and 1.1-19**

The octane adjustment potentiometer is a spark adjust input signal which is used by the electronic control module to select a spark retard condition to allow for the use of low octane fuel. This is a "dealer only" adjustment, and can only be adjusted with the use of the Tech 1 diagnostic tool.

When the vehicle is assembled, this adjustment is usually set to a "no retard" value, shown on the Tech 1 diagnostic tool F0: data list parameter "octane adjust" as "0°". This will mean that the octane adjustment potentiometer has been adjusted for premium octane fuel, and the appropriate values for spark advance will be used.

If a lower octane fuel is to be used, the dealer would use the Tech 1 diagnostic tool to adjust the potentiometer for some appropriate value of less spark advance, to compensate for the low octane fuel. The display on the Tech 1 will show negative numbers as the potentiometer has been turned further away from its initial setting of 0°

As an example for explanation purposes, let's say that the total spark advance for premium octane fuel is 35° before top dead center at some specified revolutions per minute and engine load. If a mechanic wanted to adjust the total spark advance for 8° less total advance, after making the adjustment using the Tech 1, the tool would display "octane adjustment" of -8°, and total spark advance would now be only 27° before top dead center.

If a problem occurs in the octane adjustment potentiometer circuits, after a period of time the electronic control module will store a code in its memory and turn "ON" the "Check Engine" light, indicating there is a problem. If this occurs, the electronic control module will calculate a "substitute" value of ignition timing retard to accommodate the lowest octane fuel, based on a substitute value stored in the electronic control module's memory.

A failure in the octane adjustment potentiometer circuits should set a Code 54. Remember, this code indicates a failure in the *circuit*, so proper use of the diagnostic chart will lead to either repairing a wiring problem or replacing the potentiometer, to properly repair a problem.

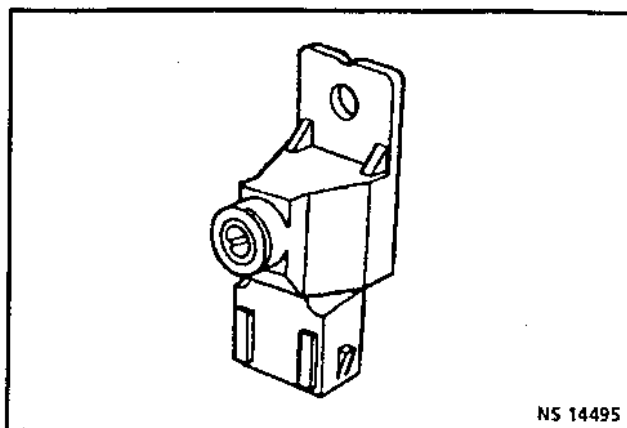

Figure 1.1-18 - Octane Adjustment Potentiometer

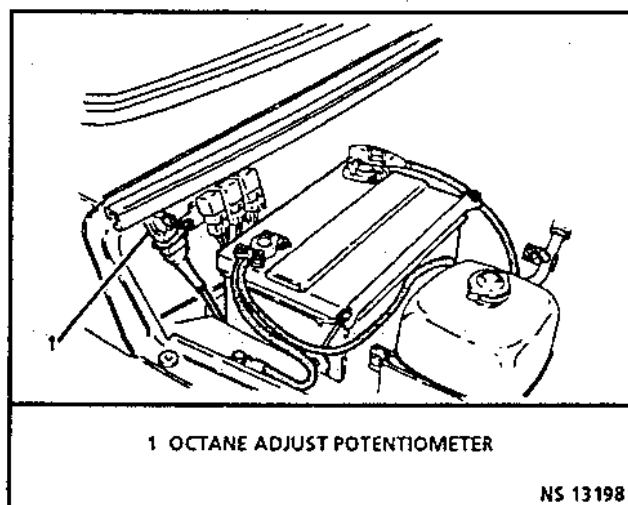

Figure 1.1-19 - Octane Adjust Potentiometer Location View

**Air Conditioning Request Signal**

When received, this signal tells the electronic control module that the driver wants the air conditioning to operate. The signal originates at the instrument panel air conditioning switch, but must pass through several temperature and pressure switches before arriving at the electronic control module. The electronic control module uses this signal to ① adjust the idle air control position to compensate for the additional load placed on the engine by the air conditioning compressor, and then ② energizes the air conditioning control relay, to operate the air conditioning compressor.

## 1.2 FUEL CONTROL SYSTEM

### GENERAL DESCRIPTION

The basic function of the fuel control system is to control fuel delivery to the engine.

The fuel control system (Figure 1.2-1) starts with the fuel in the fuel tank. An electric fuel pump located inside the fuel tank pumps fuel through the in-line fuel filter and fuel supply line to the throttle body injection unit. The pump is designed to provide pressurized fuel at considerably above 190 kPa (27.6 psi, 1.9 bar). A pressure regulator in the throttle body injection unit keeps fuel available to the injector at a constant pressure between 190 kPa (27.6 psi, 1.9 bar) and 210 kPa (30 psi, 2.1 bar). Fuel in excess of injector needs is returned to the fuel tank by a separate return line.

The injector, located in the throttle body injection unit, is controlled by the electronic control module. It delivers fuel in one of several modes as described later in this section.

### COMPONENTS

The fuel control system is made up of the following parts:

- Fuel system electrical control relay
- Fuel pump
- Fuel filter
- Fuel lines
  - Pressure (supply)
  - Return
- Fuel pressure test fitting
- Throttle body injection unit
  - Fuel injector
  - Fuel pressure regulator
  - Idle air control valve
  - Throttle position sensor

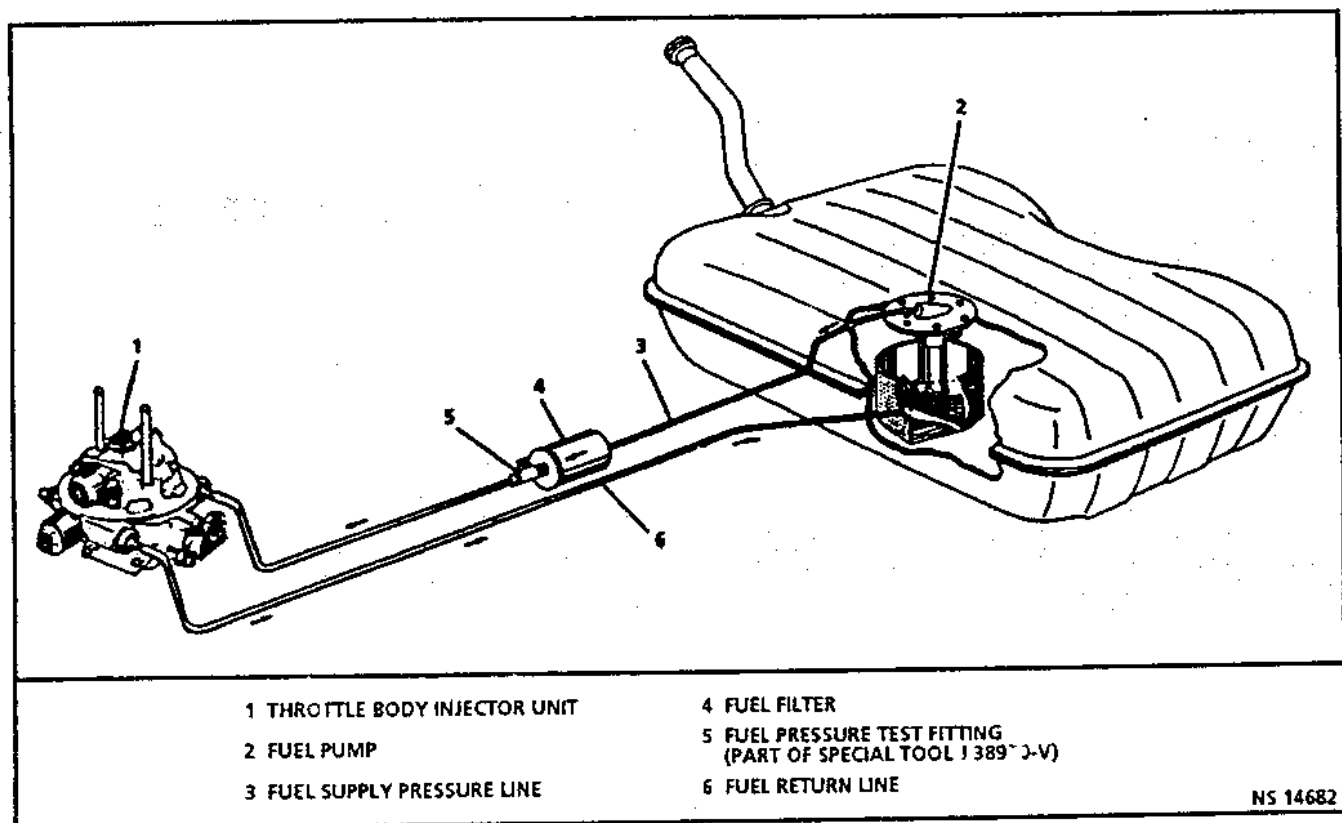

Figure 1.2-1 - Throttle Body Injection Fuel Supply System

**FUEL PUMP**

**Figure 1.2-2**

The fuel pump is an electric roller vane type pump. Fuel is pumped at a positive pressure of more than 190 kPa (27.6 psi, 1.9 bar) from the fuel pump through the in-line fuel filter to the throttle body injection unit. Excess fuel above the regulated pressure is routed through the pressure regulator in the throttle body injection assembly, to the fuel tank through the fuel return line.

Vapor lock problems are reduced when using an electric in-tank fuel pump because the fuel is under pressure rather than under a vacuum, as is the case with an engine mounted mechanical fuel pump.

**FUEL FILTER**

**Figure 1.2-3**

The fuel filter is mounted in the engine compartment under the spare tire. The filter is located in the fuel pressure (supply) line, between the fuel pump and the throttle body injection assembly. The filter housing is constructed of steel, with threaded fittings on both ends. The filter element is made of paper, and is designed to trap particles in the fuel that may damage the injection system.

When the ignition switch is turned to "ON" or "CRANK" after having been "OFF" for at least 15 seconds, the electronic control module will immediately energize the fuel system relay to operate the fuel pump. This builds up the fuel pressure quickly. If the engine is not cranked within two seconds, the electronic control module will shut the relay "OFF" and wait until the engine is cranked. As soon as the engine begins cranking, the electronic control module will sense the engine turning from the crankshaft position reference signal, and turn the relay "ON" again to run the fuel pump.

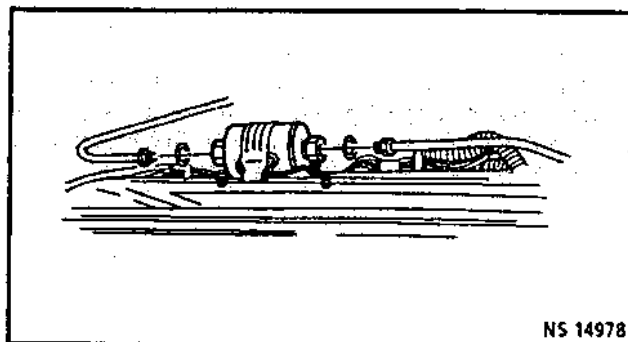

Figure 1.2-3 Fuel Filter

**FUEL SYSTEM ELECTRICAL CIRCUITS**

**Figure 1.2-4**

In order to properly control the fuel supply, the electric fuel pump is operated by the fuel system relay. This relay also supplies +12 volts to the fuel injector. The relay is controlled by the electronic control module.

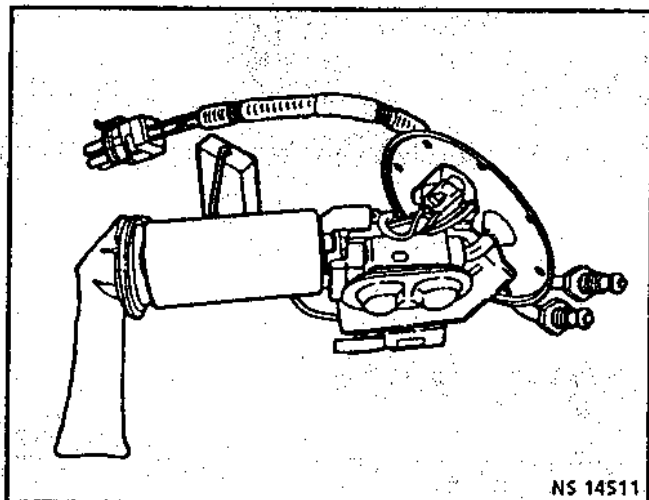

Figure 1.2-2 Electric In-Tank Fuel Pump

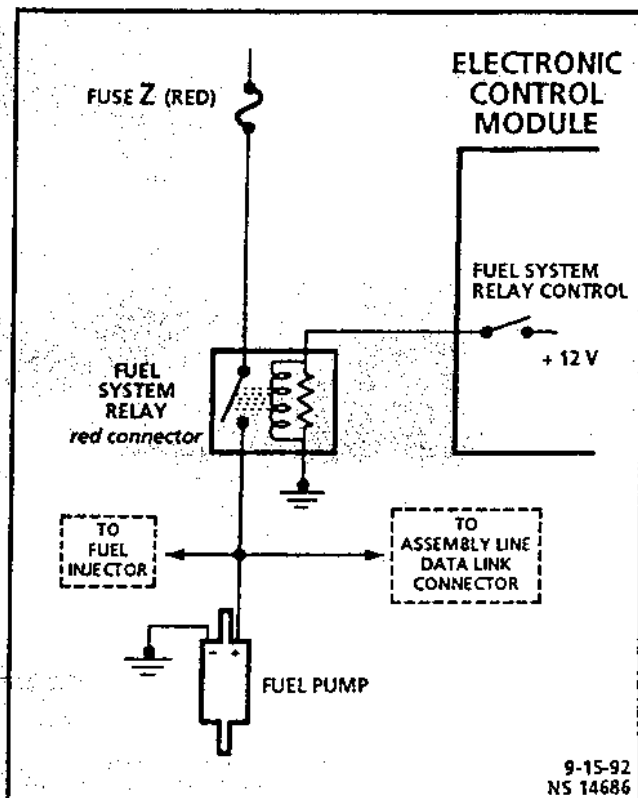

Figure 1.2-4 Fuel System Electrical Circuits

**THROTTLE BODY INJECTION UNIT**

**Figure 1.2-5**

Fuel is delivered into the engine by a throttle body injection unit. The throttle body injection unit, Model 700, is located centrally on the intake manifold, and consists of two major assemblies:

1. A Throttle Body, with a throttle valve connected to the accelerator pedal linkage, to control air flow.
2. A Fuel Meter Assembly, with an integral fuel pressure regulator and an electrically actuated fuel injector, to supply the required fuel.

Other important assemblies located on a throttle body injection unit include a throttle position sensor, and a device for idle control, the idle air control valve. The throttle body portion also contains ports located in the throttle bore (above and below the throttle valve), which are used to generate the vacuum signals required for operation of the manifold absolute pressure sensor and the evaporative emissions storage canister.

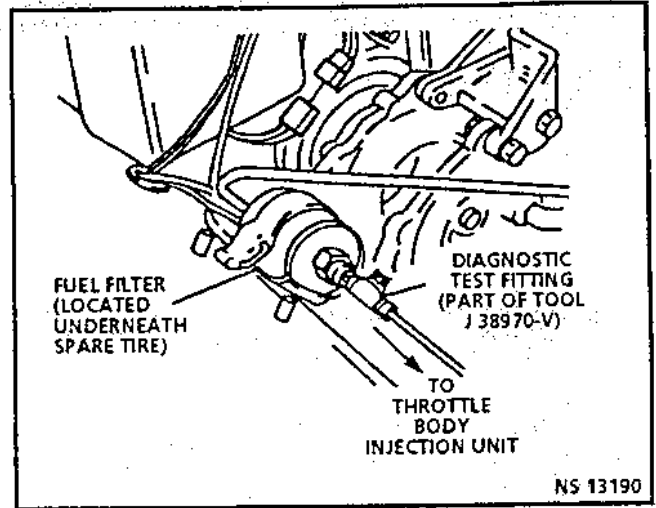
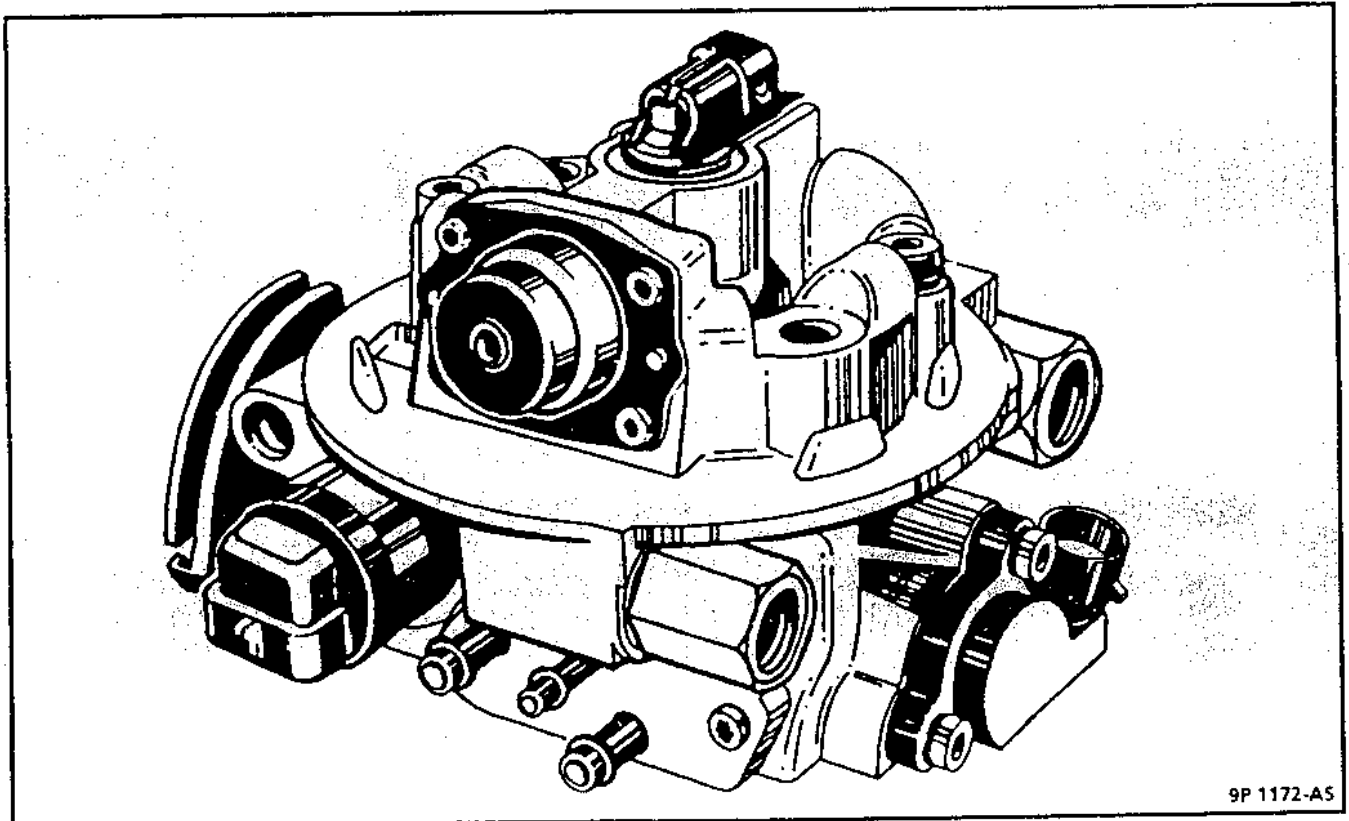

**Figure 1.2-6 - Fuel Pressure Diagnostic Fitting**

**Fuel Pressure Diagnostic Fitting**

**Figure 1.2-6**

Some diagnostic service procedures require that a fuel pressure test be performed. Special tool J 38970-V includes a diagnostic test fitting. During testing, this fitting is temporarily installed in the fuel pressure supply line at the outlet fitting of the fuel filter. This fitting provides a convenient location to connect a fuel pressure gauge, to determine the fuel pressure being delivered to the fuel injector.



**Figure 1.2-5 - Model 700 Throttle Body Injection Unit**

**Fuel Injector**  
**Figure 1.2-7**

A fuel injector is an electromagnetic device containing a solenoid which upon receiving an electrical pulse from the electronic control module pulls the plunger or core piece upward allowing the spring-loaded ball valve to come off the valve seat permitting fuel to flow through a fine screen filter to the atomizer or spray nozzle. The fuel, under pressure, is directed in a conical spray pattern at the walls of the throttle body bore above the throttle valve. When the electrical pulse is complete, the electromagnet is deenergized, and the spring-loaded ball valve closes, shutting "OFF" the fuel spray.

The injector when turned "ON" (energized) by the electronic control module has full system voltage applied to the solenoid coil until the current rises to a reference level of 4 amperes. Current regulation by the electronic control module then takes over maintaining a hold current of 1 ampere until the injector is turned "OFF." This allows a fast pull-in of the solenoid during turn-"ON" and a low energy holding state which prevents the solenoid coil from overheating. This current limiting feature is used due to the low resistance of the throttle body injection 700 fuel injector solenoid coil. Nominal resistance is 1.52 ohms  $\pm$  0.1 at 22°C.

**Fuel Pressure Regulator**  
**Figure 1.2-7**

Fuel is supplied to the throttle body injection unit from a constant flow fuel pump. A filter in the fuel supply line protects the precision components within the throttle body injection unit from damage by fuel borne solids.

A diaphragm controlled flow valve within the fuel meter assembly maintains fuel pressure within specified limits. Regulation is achieved by balancing fuel pump pressure against the preset tension of the pressure regulator spring.

Should fuel pressure drop below the design limit, the pressure regulator spring forces the diaphragm and valve against the valve seat. With the regulator valve closed, fuel returning back to the fuel tank is stopped, and inlet pressure is allowed to increase. Fuel pressure above the design limit overcomes the pressure regulator spring tension, pushing open the valve to bleed excess pressure into the fuel return line.

Fuel flow calibration is based on holding the system's fuel pressure within specified limits. To accomplish this, the fuel pump must produce sufficient pressure to overcome the pressure regulator preset tension.

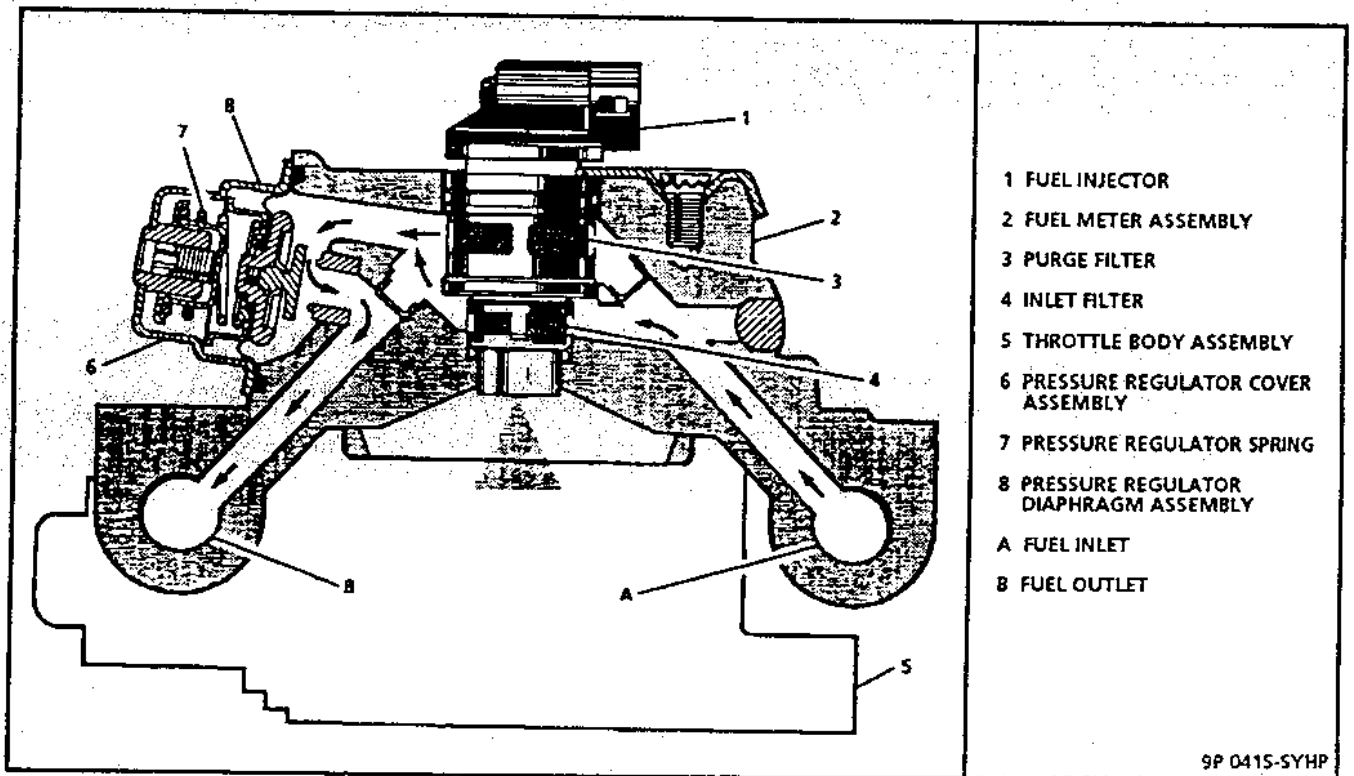

Figure 1.2-7 Fuel Injector and Pressure Regulator, Shown in the Fuel Meter Assembly

## Fuel Metering Figure 1.2-7

Accurate fuel metering in the Model 700 throttle body injection unit results from the precise regulation of fuel pressure and injector timing. An injector control signal consisting of a series of "ON" and "OFF" pulses originates from the electronic control module in response to engine fuel needs. This series of pulses is usually synchronized with engine speed signal (crankshaft reference) pulses that are sent to the electronic control module from the ignition system. The injector control signal when applied to the injector, energizes the injector's solenoid. The solenoid opens a normally closed ball valve releasing a conical spray of pressurized fuel into the throttle bore just above the throttle valve.

Since fuel pressure is held constant by the regulator, the volume of fuel flow is proportional to the length of time that the injector is held open (pulse width) and the frequency (repetition rate) of the applied pulses. By varying the pulse width, the electronic control module maintains the optimum air/fuel ratio. Increasing the pulse width results in a greater fuel flow (enriched air/fuel ratio). A reduction in pulse width decreases the fuel flow resulting in a leaner air/fuel ratio. The repetition rate is generally determined by engine speed. The electronic control module initiates injector pulses by monitoring engine speed from a crankshaft position reference signal to the electronic control module from the ignition system.

The electronic control module modifies pulse width to meet the changes in engine fuel demand (such as cold starts, altitude, acceleration, deceleration, et cetera).

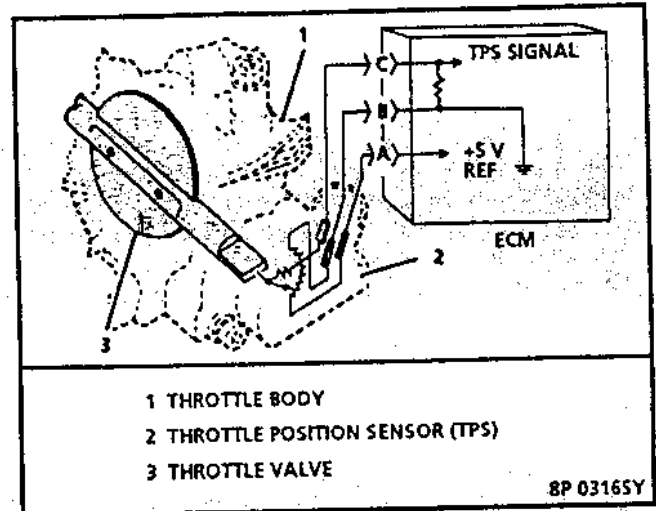

Figure 1.2-8 Throttle Position Sensor Circuits

## Throttle Position Sensor Figure 1.2-8

The throttle position sensor is a part of the throttle body injection unit. It is mounted on the side of the throttle body opposite the throttle lever assembly. As the throttle valve rotates in response to movement of the accelerator pedal, the throttle shaft transfers this rotational movement to the throttle position sensor. When this occurs, the throttle position sensor output signal voltage changes. More information about the throttle position sensor is available in Section 1.1 "Electronic Control Module and Sensors," of this manual.

**IDLE AIR CONTROL VALVE**

**Figure 1.2-9**

The idle air control valve assembly consists of a two-coil, bi-polar stepper motor connected to a tapered pintle valve. Seated in the idle air bypass channel of the throttle body injection unit (Figure 1.2-9), the idle air control valve pintle extends or retracts in response to control signals supplied by the electronic control module. The idle air control valve adjusts idle speed by controlling the amount of bypass air around the closed throttle valve.

When fully extended (seated = zero (0) steps), the pintle valve blocks the flow of bypass air around the throttle valve. Retracting the pintle allows bypass air to flow in proportion to the number of steps the pintle moves away from its seat (fully retracted = 255 steps).

Since the electronic control module can command the idle air control valve to move any number of steps (0-255 from fully extended to fully retracted), the volume of idle bypass air (and ultimately, engine revolutions per minute) is adjusted to meet closed throttle engine loading.

Closed throttle desired engine speed (in revolutions per minute) is programmed into the electronic control module for normal engine conditions. The idle air control valve, under control of the electronic control module, allows an increase or decrease in idle speed as engine conditions warrant.

Besides controlling idle speed, the idle air control valve helps to reduce emissions. When the throttle is closed during vehicle deceleration from road speed, the idle air control valve allows an increased bypass air flow to go around the closed throttle valve, producing a leaner air/fuel mixture. This reduces hydrocarbon and carbon monoxide emissions that occur during rapid throttle closing.

There is no direct signal to the electronic control module as to the actual position of the idle air control valve. The electronic control module "resets" the idle air control valve each time the ignition is turned "OFF." This is accomplished by causing the idle air control valve to fully extend to a seated, shut position (0 steps) after the engine stops. At this position, the control module "knows" the valve is at a "zero" position. The control module then retracts the valve a calculated number of steps, to allow sufficient air for subsequent engine starts.

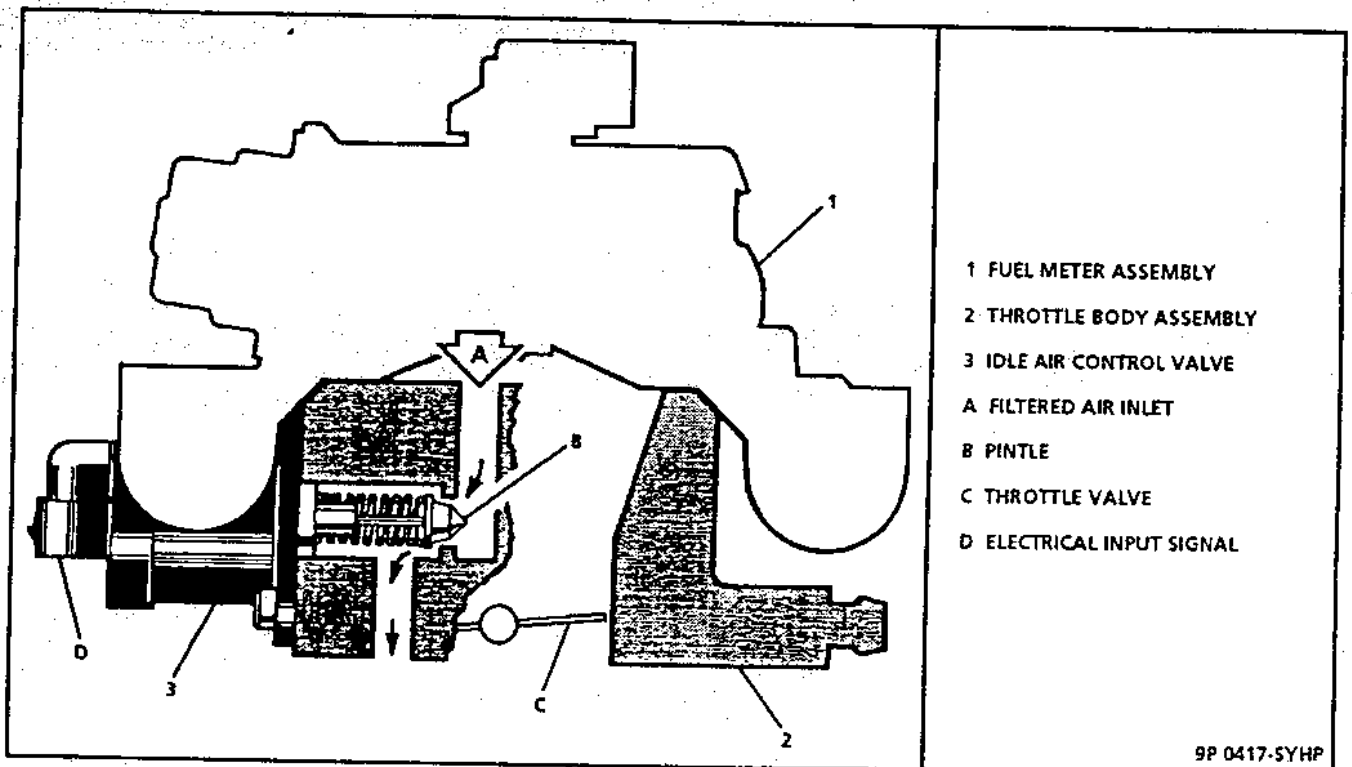

Figure 1.2-9 Idle Air Control System



### SPEED-DENSITY FUEL CONTROL

The NIVA 1.7L throttle body injection engine management system uses what is called a "speed-density" method of calculating the correct fuel requirements, for any engine operating condition. An air/fuel mixture can be expressed as an air/fuel ratio.

In order to deliver the correct amount of fuel, the airflow going into the engine must be known. These two factors: engine speed, and air density in the intake manifold, are used together to calculate the total airflow into the engine, so that the correct amount of fuel may be delivered to maintain the desired air/fuel mixture.

This method of airflow calculation begins in an engine dynamometer laboratory. First, an actual 1.7L NIVA engine, fully equipped with the complete throttle body fuel injection system, is fitted onto a dynamometer. Then, the engine is run at all possible combinations of engine speed and load.

While this test is being performed in the laboratory, information is being entered into a laboratory computer's memory about actual engine speed, intake manifold absolute pressure, and intake air temperature. (These last two, intake manifold absolute pressure and air temperature, combine to form the "air density" factor, explained later.)

With these three pieces of information, several "lookup tables" of information are developed in the memory of the laboratory computer. One of these is called a "volumetric efficiency" lookup table, and is a comparison of the theoretical airflow through the engine based on cylinder displacement and engine speed, as compared to the calculated airflow based on intake manifold absolute pressure, intake air temperature and engine speed. Various factors of the basic engine design affect volumetric efficiency, such as camshaft lift, duration, and overlap, intake and exhaust valve size, air induction and exhaust system design, combustion chamber design, exhaust backpressure, et cetera.

Knowing what the volumetric efficiency is at any engine speed, plus knowing the air density of the available air in the intake manifold, it is possible to calculate the airflow into the engine.

These "lookup tables" of information are permanently programmed into the on-car electronic control module's memory. Equipped with the lookup tables of engine volumetric efficiency at any engine speed, plus on-vehicle measurements of intake manifold absolute pressure, intake air temperature, and actual engine speed, the vehicle's electronic control module can calculate engine airflow.

Now, on any vehicle equipped with exactly the same type engine as was measured and documented in the dynamometer laboratory, the airflow of a particular vehicle's engine can be calculated by using the lookup table of information, along with inputs from the sensors that are a part of that engine.

## SPEED-DENSITY CALCULATION

As described previously, to calculate the airflow going into the vehicle's engine, the electronic control module uses two factors—engine speed and air density. Engine speed is obtained directly from a signal coming from the ignition module. The second factor, air density, is calculated from two other sensor input signals.

### Speed

The engine speed signal comes from the ignition system, and goes to the electronic control module on its crankshaft reference input signal circuit. The electronic control module uses this information to determine the "engine speed" factor for fuel and ignition management. This engine speed signal is *the single most important input signal* to the electronic control module. Without it, the electronic control module cannot calculate any fuel injector pulses, and the engine can not run.

### Density

The density of the air, or how tightly packed are the molecules of oxygen in the intake manifold, is an indicator of how much oxygen is available to be used for combustion inside the engine. Air density can change according to atmospheric pressure, air temperature, and throttling of the incoming air on a running engine. Denser air means more molecules of oxygen, and more fuel would be required to maintain the correct air/fuel ratio. Also, less dense air requires less fuel for a proper air/fuel ratio.

The manifold absolute pressure sensor monitors the actual intake manifold absolute pressure which results from changes in engine speed and throttling, and atmospheric pressure. The manifold absolute pressure sensor sends to the electronic control module an electrical signal, with the level of voltage depending on the manifold pressure measured. Remember, higher pressure means more air and more oxygen, while lower pressure means less air and less oxygen.

As intake manifold pressure increases (such as during wide open throttle), the air density in the intake manifold also increases, and the manifold absolute pressure sensor sends this voltage signal to the electronic control module. Under these conditions the electronic control module increases the amount of fuel injected by increasing the injector pulse width.

Conversely, as manifold pressure decreases, the amount of required fuel also decreases. The manifold absolute pressure sensor's output voltage is reduced, and the injector pulse width is decreased by the electronic control module.

To complete the air density factor, the temperature of the incoming air must be known. Just as the pressure of the air in the intake manifold is an indicator of how much oxygen is available for combustion, air temperature is also an indicator. Lower air temperature is "denser," meaning it has more oxygen, while hotter air has less oxygen.

Located into the underneath side of air cleaner, the intake air temperature sensor constantly measures the temperature of the air entering the intake manifold and converts the temperature into an electrical signal sent to the electronic control module.

These three input signals: engine speed, manifold absolute pressure, and intake air temperature, are the major determinants of the "engine running" air/fuel mixture delivered by the fuel injection system. The remaining sensors provide electrical inputs to the electronic control module which are used for minor modification of the air/fuel mixture, as well as for other electronic control module control functions.

### Note about air density's effect on maximum available engine power.

For those of you who have experienced driving a vehicle at high altitude, knowing about this air density factor should help explain why the engine seems to be less powerful at high altitudes than when operated at sea level. There is less available oxygen in the less dense air found at higher altitudes! The same holds true for a hot day compared to a cool day. Needless to say, most record holders of vehicle speed records have recorded their highest speeds while operating their engines at lower altitudes on cool days, when the density of the air (and available oxygen for combustion) is at its highest possible level.

**MODES OF FUEL CONTROL OPERATION**

As discussed previously in this section, the amount of fuel delivered by the injector is controlled by an electrical signal from the electronic control module. Injection pulses normally occur once for each crankshaft position reference pulse sent from the ignition system to the electronic control module. For a four cylinder engine, these crankshaft reference pulses (and synchronous injector pulses) occur twice per crankshaft revolution (Figure 1.2-10).

The electronic control module monitors a number of engine operating conditions, calculates the fuel requirements, and determines the proper fuel injector delivery time. This delivery time is called "injector pulse width," and can be observed using the Tech 1 diagnostic tool. To increase the amount of fuel delivered, the pulse width is lengthened. To reduce the amount of fuel delivered, the pulse width is shortened. Pulse width is modified by the electronic control module for various operating conditions such as cranking, high altitude, power enrichment, or deceleration.

The electronic control module monitors several sensors to determine how much fuel the engine needs. The fuel is delivered in one of two different methods; either *synchronous*: in time with, or initiated from crankshaft reference input signal pulses (Figure 1.2-10), or *asynchronous*; independent of, or not timed with crankshaft position reference pulses (Figure 1.2-11).

Synchronous fuel delivery (that is, synchronized with or in time with crankshaft reference pulses) is the most used method of fuel delivery. Asynchronous fuel delivery is primarily used when extra fuel is required due to rapid throttle opening, as seen by the throttle position sensor. Asynchronous fuel pulses are similar to the extra fuel delivered by a carburetor accelerator pump, when the throttle is opened quickly.

Regardless of the delivery method, fuel is controlled under one of several conditions, called "modes." All of the modes are electronic control module controlled, and are described in the next few paragraphs.

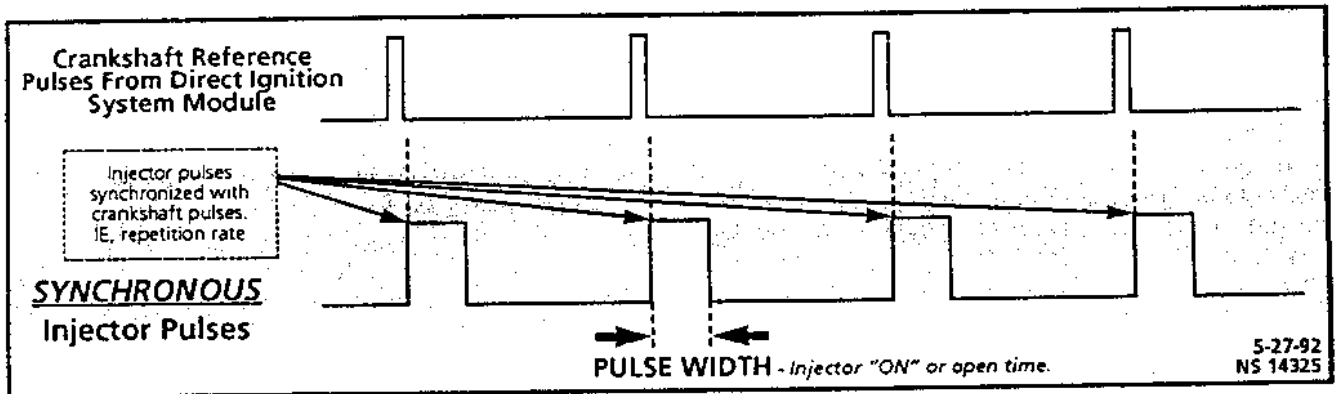

Figure 1.2-10 Crankshaft Reference -AND- Injector Pulses – SYNCHRONOUS Fuel Delivery

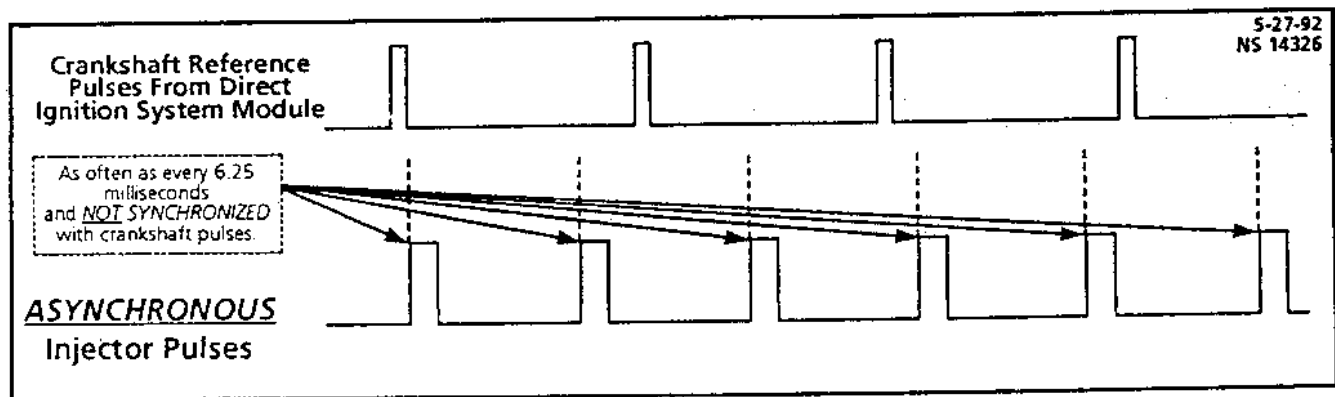

Figure 1.2-11 Crankshaft Reference -AND- Injector Pulses – ASYNCHRONOUS Fuel Delivery

### Starting Mode

When the ignition is first turned "ON," the electronic control module will turn "ON" the fuel system relay for two seconds, and the fuel pump will build up pressure to the throttle body injection unit. The electronic control module checks the coolant temperature sensor to determine the proper air/fuel ratio for starting.

When cranking begins, the electronic control module will operate in the "Starting" mode until engine revolutions per minute are more than 420, -or- the "Clear Flood" mode is enabled.

### Clear Flood Mode

If the engine floods (that is, spark plugs wetted with liquid fuel), it can be started by opening the throttle fully while cranking the engine. The electronic control module then pulses the injector with only a 26:1 air/fuel ratio (about a 2 millisecond pulse width), which should "clear" a flooded engine. The electronic control module holds this pulse width as long as the throttle position sensor input indicates the throttle is nearly wide open (more than 85%), and revolutions per minute are below 420.

If the throttle is held wide-open while attempting to make a normal start with a non-flooded engine, the engine may not start. A 26:1 air/fuel mixture may not be enough fuel to start a non-flooded engine, especially if it is cold.

### Run Open Loop Mode

After the engine is running (revolutions per minute more than 420), the electronic control module will operate the fuel control system in the "Open Loop" mode. In "Open Loop," the electronic control module calculates the injector pulse width without the use of the oxygen sensor. Calculations are based on inputs from the crankshaft reference signal (revolutions per minute input) and these sensors: manifold absolute pressure, intake air temperature, coolant temperature, and throttle position sensor.

In "Open Loop," the calculated pulse width may give an air/fuel ratio other than 14.7 to 1. An example of this would be when the engine is cold, because a richer mixture is needed to ensure good driveability.

The system will stay in the "Open Loop" mode until *all* the following conditions have been met:

1. The oxygen sensor has a varying voltage output, indicating that it is hot enough to operate properly. This is described fully in the previous section on electronic control module and sensor operation.

2. The engine coolant temperature is more than 32°C.
3. The engine has been running more than a period of time, since the engine was started. The time can vary between 6 seconds up to 5 minutes, based on the coolant temperature when the engine was started. At the extremes, if engine coolant temperature was less than 18°C at startup, then 5 minute would apply. If the coolant temperature was more than 75°C at startup, the 6 second delay would apply.

### Run "Closed Loop" Mode

In "Closed Loop" mode, the electronic control module initially calculates injector pulse width based on the same sensors used in "Open Loop." The difference is that in "Closed Loop," the electronic control module uses the exhaust gas oxygen sensor signal to modify and precisely fine tune the fuel pulse width calculations in order to precisely maintain the 14.6 to 14.7: 1 air/fuel ratio that allows the catalytic converter to operate at its maximum conversion efficiency.

### Acceleration Enrichment Mode

The electronic control module looks at rapid increases in throttle position and manifold pressure, and provides extra fuel by increasing the injector pulse width. If the increased fuel requirements are great enough due to rapid throttle opening, the electronic control module may add extra asynchronous fuel injection pulses between the synchronous injector pulses that normally occur once per crankshaft position reference pulse.

The acceleration enrichment mode is for transitional (when the throttle is moving) fueling needs only.

### Power Enrichment Mode

The electronic control module monitors the throttle position sensor and engine speed to determine when maximum engine power is being requested by the driver. Maximum engine power output requires a richer mixture (more fuel) than 14.7 to 1. When the power enrichment mode is active, the electronic control module changes the air/fuel ratio to approximately 12 : 1. When this mode is active, the oxygen sensor signal is ignored, since its signal would be indicating a rich exhaust. The status of this mode can be observed using the Tech 1 diagnostic tool.

### Deceleration Enleanment Mode

When closed throttle engine deceleration occurs, the fuel remaining in the intake manifold can cause excessive emissions. The electronic control module monitors for a reduction in both throttle position and manifold pressure, and reduces the fuel by decreasing the pulse width.

### Decel Fuel Cut Mode

When closed throttle deceleration from high road speed occurs with the transmission in gear and the clutch engaged, the electronic control module has the ability to cut off fuel pulses completely for short periods. This is called the Decel Fuel Cut mode. The status of this mode can be observed using the Tech 1 diagnostic tool.

The decel fuel cut mode occurs when *ALL* these conditions are met:

1. Coolant temperature above 44°C.
2. Engine revolutions per minute above 3150.
3. Vehicle speed above 42 km/h.
4. Throttle is closed.
5. Manifold absolute pressure input indicates no engine load (less than 24 kPa).
6. Transmission is determined to be "in gear," by a lookup table comparing engine speed with vehicle speed.

When decel fuel cut is in effect, *ANY* one of these can cause injection pulses to restart:

1. Engine revolutions per minute below 2100.
2. Vehicle speed is less than 42 km/h.
3. Throttle is open at least 2%.
4. Manifold absolute pressure input indicates some engine load (more than 25 kPa).
5. Clutch is determined to be "de-clutched," or disengaged. This can be determined if the engine revolutions per minute is dropping very rapidly.

### Battery Voltage Correction Mode

At low battery voltages, the ignition system may deliver a weak spark, and the injector mechanical movement takes longer to "open." The electronic control module will compensate by:

- Increasing ignition coil dwell time if voltage is less than 12 volts.
- Increasing idle engine speed revolutions per minute and injector pulse width, if voltage drops below 8 volts.

### Fuel Cutoff Mode

No fuel is delivered by the injector when the ignition is "OFF." This prevents dieseling. Also, fuel pulses are not delivered if the electronic control module receives no crankshaft reference pulses from the ignition module, which means the engine is not running.

The Fuel Cutoff Mode is also enabled at:

- High engine speed, as an overspeed protection for the engine. When fuel cutoff is in effect due to engine speed of more than 6,500 revolutions per minute, injection pulses will resume after engine speed drops below 6,300.

## Adaptive Adjustment of Fuel Injector Pulsewidth

Adaptive learning is the ability of the on-board computer to measure the results of its calculations and output commands, and then remember and act upon its most recent operating experience. The electronic control module uses this remembered information to "learn from experience," and to make adjustments according to what it learned.

As an example, with respect to "Closed Loop" fuel control, if the fuel supply system were to develop low fuel pressure, the oxygen sensor input signal to the electronic control module would indicate a lean exhaust condition. The electronic control module will immediately adjust the injector control pulse width richer ("Closed Loop Fuel Adjustment") to correct for this exhaust condition, and after a length of time will transfer this *adjustment value* into memory ("Memory Fuel Adjustment"). The electronic control module will use this adjustment in its injector pulsewidth calculations until the fuel pressure problem is repaired.

After repairs have been performed, the electronic control module will eventually relearn to the original preprogrammed injector pulse width. The Closed Loop fuel adjustment, using the oxygen sensor signal, updates or "relearns" the memory fuel adjustment value, when the fuel control system is operating in the "Closed Loop" mode.

Memory fuel adjustment is used during both "Open" and "Closed Loop" fuel control. However, the memory fuel adjustment value is updated, or "relearned" only in "Closed Loop."

Adaptive learning is an on-going process that continues throughout the life of the vehicle.

## Closed Loop Fuel Adjustment

Closed Loop fuel adjustment represents adjustments to the fuel injector pulse width calculations, based on the oxygen sensor input signal to the electronic control module, when the fuel control system is operating in the "Closed Loop" mode.

When the engine is first started, the electronic control module will control the fuel injection pulse width in the "Open Loop" mode, based upon various sensor inputs such as manifold absolute pressure, engine speed, coolant temperature, and throttle position. During this "Open Loop" period, "closed loop fuel adjustment" is disabled and will read 0% on the Tech 1 "Scan" tool.

When the oxygen sensor has come up to its normal operating temperature it will produce a varying voltage to the electronic control module and provide a good indication of what has happened in the combustion chambers. At this time the electronic control module will change from "Open Loop" to "Closed Loop" fuel control, and the Closed Loop fuel adjustment will start to constantly monitor the oxygen sensor signal, so that the electronic control module can calculate and/or modify the fuel injector pulse width with greater accuracy than in "Open Loop."

The "no correction needed" value for Closed Loop fuel adjustment is 0%. Any change from 0% indicates the Closed Loop fuel adjustment is modifying the fuel injector pulse width. If the Closed Loop fuel adjustment value is above 0%, the fuel injector pulse width is being increased, thus adding more fuel. If the Closed Loop fuel adjustment value is below 0%, the fuel injector pulse width is being decreased, thus removing fuel. The normal operating range of Closed Loop fuel adjustment is considered to be between -20% and +20%; any value out of this range is usually caused by a malfunction.

If the exhaust is lean, additional "Closed Loop fuel adjustment" fuel pulsewidth will be added until the oxygen sensor signal voltage indicates the exhaust is rich. The opposite is also true: if the exhaust is too rich, the "Closed Loop fuel adjustment" will reduce the injector pulsewidth until it detects a lean exhaust. If the Closed Loop fuel adjustment continues to see a low or high oxygen sensor signal voltage (lean or rich exhaust), it will continue to try and compensate for the exhaust condition until it reaches its limits of control.

The calibrated limits of Closed Loop Fuel Adjustment are set to allow (from the original calculation) no more than +63% of additional pulsewidth, or to reduce pulsewidth by a maximum reduction of -54%.

These changes in Closed Loop fuel adjustment occur only during "Closed Loop" fuel control, and are used to update the "Memory Fuel Adjustment."

## Memory Fuel Adjustment

"Memory fuel adjustment" is a portion of the electronic control module memory used to adjust fuel delivery across all operating conditions of the engine, even during open loop fuel control. "Memory fuel adjustment" monitors the "closed loop fuel adjustment," and will modify a "learned" memory value of fuel injector pulse width correction, if the Closed Loop fuel adjustment has been high or low for a certain period of time. Memory fuel adjustment is relearned or updated only when the fuel control system is operating in "Closed Loop" mode. A "no correction needed" memory value is 0%, with normal ranges of adjustment being between -10% and +10%.

The calibrated limits of Memory Fuel Adjustment are set to allow (from the original calculation) no more than +50% of additional pulsewidth, or to reduce pulsewidth by a maximum reduction of -38%.

Memory fuel adjustment provides the electronic control module with the ability to make semipermanent changes to its injector pulsewidth calculations, to compensate for normal changes or "build tolerances" in the operating characteristics of all the fuel handling components.

As an example of how the "closed loop fuel adjustment" and "memory fuel adjustment" can compensate for some causes of a too-rich or too-lean exhaust, follow this next example:

If the fuel pressure were to suddenly increase above acceptable limits for any reason, the exhaust gases would quickly change to a rich condition. This happens because with fuel pressure that is too high, the actual delivered fuel from the injector would increase, even though the pulsewidth stayed the same.

If the fuel control system were operating in the "Closed Loop" mode, the "closed loop fuel adjustment" value would immediately decrease to less than 0%, maybe (for example) to -15%, to decrease the injector pulsewidth. If this Closed Loop fuel adjustment value change did not compensate for the subsequent too-rich exhaust, the electronic control module will continue to decrease the Closed Loop fuel adjustment value. The "Closed Loop fuel adjustment" value may decrease as low as its calibrated minimum allowable limit (-54%) if there is a continued rich exhaust indication. (This example could be a real situation, if for any reason the "return fuel" line, needed to return excess fuel pressure back to the fuel tank, were to become pinched shut.)

The "memory fuel adjustment" will monitor the "closed loop fuel adjustment" value as it decreases, but it will not make any changes of its own to the fuel injector pulse width for a period of time. After a period of time has elapsed and the Closed Loop fuel adjustment value has remained low, the memory fuel adjustment will decrease a small amount to (example) -5%, and wait to see if the Closed Loop fuel adjustment has come back up to 0%.

If after this memory fuel adjustment is made, the Closed Loop fuel adjustment continues to be less than 0%, the "memory fuel adjustment" will continue to move down toward its calibrated minimum limit (-38%), attempting to optimize the air/fuel mixture of the fuel injection control system.

When the "Memory Fuel Adjustment" value has sufficiently increased or decreased the injector pulsewidth, meaning that the oxygen sensor indicates the exhaust is now neither too rich or lean, the "Closed Loop Fuel Adjustment" will return to approximately 0%, making no further pulsewidth correction. In our previous example of abnormally high fuel pressure, the hopeful end result is that the "Memory Fuel Adjustment" value might go down to -25%, and the "Closed Loop Fuel Adjustment" would return to 0%.

If both "Memory Fuel Adjustment" and "Closed Loop Fuel Adjustment" have moved to each of their adjustment limits, after a short period of time the fuel control system will be determined to be "out of control." When this occurs, the electronic control module will turn "ON" the Check Engine light and store in its memory either a Diagnostic Trouble Code 44 (lean exhaust) or 45 (rich exhaust), and change back into "open loop" fuel control.

If either the Acceleration Enrichment, Power Enrichment, or Decel Fuel Cut modes are in effect, the electronic control module sets the "Closed Loop fuel adjustment" to 0% and holds it there until these fuel control modes are no longer in effect. This is done so that the memory fuel adjustment will not try to correct for the commanded richness or leanness of any of these three normal modes of fuel control.

### Memory Fuel Adjustment Cell

Figure 1.2-12

The memory fuel adjustment function of the electronic control module is divided up into two different sets of 16 cells, arranged by boundaries of engine load (manifold absolute pressure) and engine speed (revolutions per minute). The two different sets of cells represent two different lookup tables. The choice between the two tables is selected by whether or not the evaporative emissions storage canister solenoid is being commanded "ON" or "OFF." There are two additional "idle" cells, each with selections dependent on air conditioning operation and evaporative emissions purge operation.

Each cell corresponds to a region on the engine load versus engine speed table, shown below. Each region is initially calibrated to a memory fuel adjustment value of 0%. A value of 0% in a given cell indicates no fuel adjustment is needed for that engine speed and load condition. A higher number, for example +3%, indicates that the electronic control module has seen a lean exhaust indication under those conditions, and is adding fuel (increasing fuel injector pulse width) to compensate.

Conversely, a lower number, for example -5%, indicates that the electronic control module has seen a rich exhaust indication under those load conditions, and is subtracting fuel (decreasing fuel injector pulse width) to compensate.

The electronic control module will keep the latest memory values stored in its memory fuel adjustment cells. Manifold absolute pressure sensor pressure readings and engine speed are used by the memory to determine what "adjustment cell" to use. Memory fuel adjustment values are stored in the electronic control module's long term memory, for use each time the engine speed and load matches one of the memory cells. All memory fuel adjustment values are reset to 0% when the electronic control module's "long term memory power supply" is disconnected, as when the negative battery cable is disconnected to clear any stored diagnostic trouble codes.

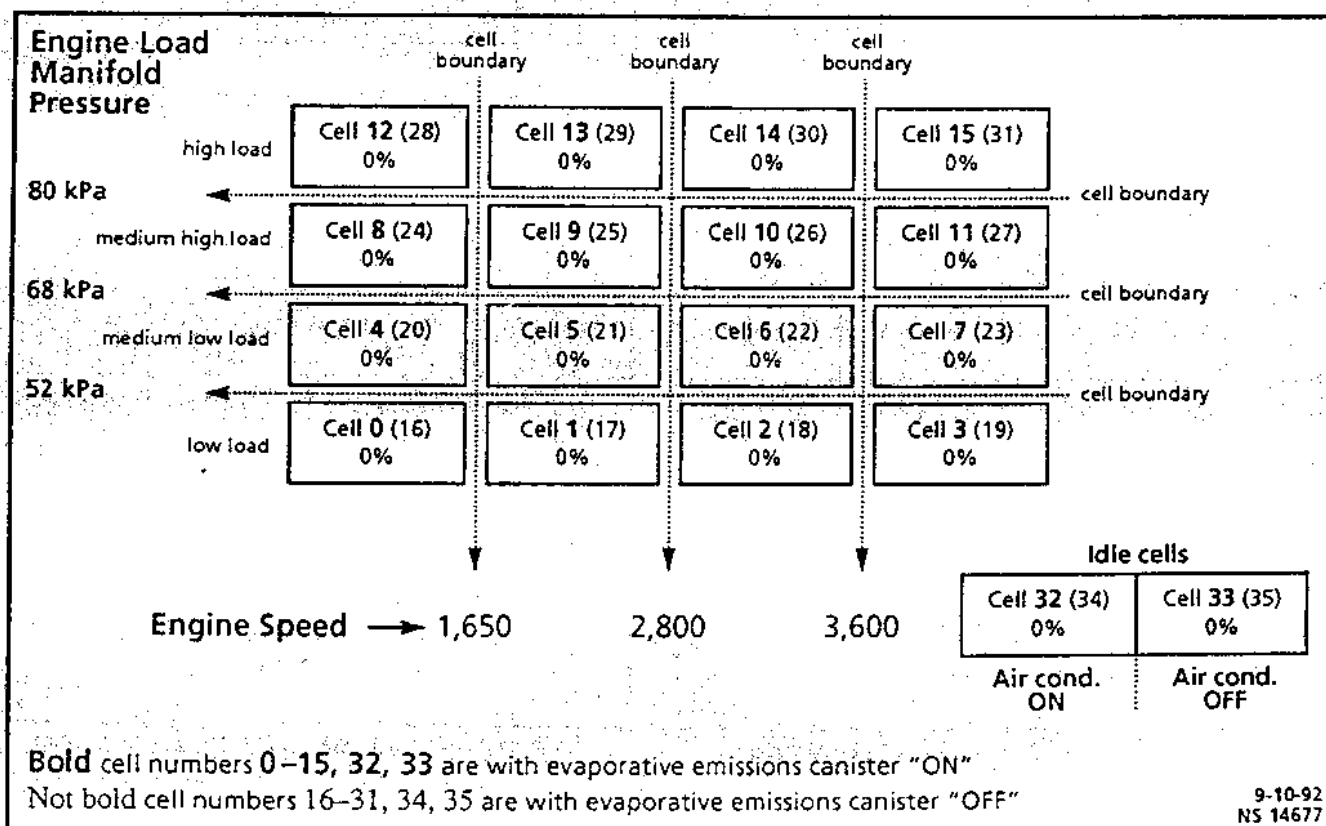

Figure 1.2-12 Memory Fuel Adjustment Cell Matrix



# 1-34 ENGINE MANAGEMENT SYSTEMS 1.7L THROTTLE BODY INJECTION

As the vehicle is driven from a standing stop and accelerated or decelerated from various engine speeds, the memory will change from one cell to another cell. When the engine is idling, it will be in cell #32 – 35. If the engine is operating at 3,000 revolutions per minute and the manifold pressure is at 60 kPa, the electronic control module will be using the memory fuel adjustment value from cell #6/22. Whatever cell the engine is operating in, the electronic control module will read that cell's particular memory fuel adjustment value, and adjust the fuel injector pulse width to compensate for a rich or lean condition in the engine (Figure 1.2-13).

As an example, if an engine has low fuel pressure and the customer has driven the vehicle like this for quite some time, the Closed Loop fuel adjustment value would have been high, and the electronic control module would be compensating for this lean exhaust condition by adding more fuel, by increasing the injector pulsewidth. Because the Closed Loop fuel adjustment value is above 0%, memory fuel adjustment will also be greater than 0% in most of the cells to compensate for the lean exhaust.

If you suspect a driveability problem associated with a rich or lean condition, then use the Closed Loop fuel adjustment value to see what the fuel control system is doing *at the present time*. Use the memory fuel adjustment to identify what the system has "learned" *over a greater period of time* to compensate for the condition. Use the memory cells to determine if the fuel control system is rich or lean throughout the operating range (Figure 1.2-14 and 1.2-15). If it is only rich or lean at idle or part throttle, look for components that would cause problems in these areas.

|                      |                      |                      |                      |
|----------------------|----------------------|----------------------|----------------------|
| Cell 12 (28)<br>+11% | Cell 13 (29)<br>+16% | Cell 14 (30)<br>+7%  | Cell 15 (31)<br>+40% |
| Cell 8 (24)<br>+16%  | Cell 9 (25)<br>+33%  | Cell 10 (26)<br>+18% | Cell 11 (27)<br>+10% |
| Cell 4 (20)<br>+4%   | Cell 5 (21)<br>+15%  | Cell 6 (22)<br>+13%  | Cell 7 (23)<br>+21%  |
| Cell 0 (16)<br>+8%   | Cell 1 (17)<br>+20%  | Cell 2 (18)<br>+14%  | Cell 3 (19)<br>+22%  |
| Cell 32 (34)<br>+10% |                      | Cell 33 (35)<br>+12% |                      |

5-27-92  
NS 14678

Figure 1.2-14 - Example of Lean Exhaust – All Cells

|                     |                     |                     |                     |
|---------------------|---------------------|---------------------|---------------------|
| Cell 12 (28)<br>+1% | Cell 13 (29)<br>+1% | Cell 14 (30)<br>0%  | Cell 15 (31)<br>0%  |
| Cell 8 (24)<br>+1%  | Cell 9 (25)<br>0%   | Cell 10 (26)<br>0%  | Cell 11 (27)<br>-1% |
| Cell 4 (20)<br>+4%  | Cell 5 (21)<br>-1%  | Cell 6 (22)<br>0%   | Cell 7 (23)<br>+2%  |
| Cell 0 (16)<br>0%   | Cell 1 (17)<br>+3%  | Cell 2 (18)<br>+1%  | Cell 3 (19)<br>-2%  |
| Cell 32 (34)<br>+1% |                     | Cell 33 (35)<br>-2% |                     |

5-27-92  
NS 14434

Figure 1.2-13 - Typical Adaptive Memory Values

|                      |                     |                      |                     |
|----------------------|---------------------|----------------------|---------------------|
| Cell 12 (28)<br>-5%  | Cell 13 (29)<br>-4% | Cell 14 (30)<br>-8%  | Cell 15 (31)<br>-3% |
| Cell 8 (24)<br>-9%   | Cell 9 (25)<br>-6%  | Cell 10 (26)<br>-10% | Cell 11 (27)<br>-1% |
| Cell 4 (20)<br>-4%   | Cell 5 (21)<br>-1%  | Cell 6 (22)<br>-7%   | Cell 7 (23)<br>-20% |
| Cell 0 (16)<br>-10%  | Cell 1 (17)<br>-30% | Cell 2 (18)<br>-13%  | Cell 3 (19)<br>-2%  |
| Cell 32 (34)<br>-12% |                     | Cell 33 (35)<br>-24% |                     |

5-27-92  
NS 14980

Figure 1.2-15 - Example of Rich Exhaust – All Cells

## 1.3 EVAPORATIVE EMISSION CONTROL SYSTEM

### GENERAL DESCRIPTION

#### PURPOSE

The evaporative emission control system used is the charcoal canister storage method. This method transfers fuel vapor from the fuel tank to an activated carbon (charcoal) storage device (canister) to hold the vapors when the engine is not operating (Figure 1.3-3). The purpose of the canister purge control system is to control the release of fuel vapors from the vapor collection canister into the engine intake manifold, so they are burned in the combustion process. This control is accomplished by using an electrically operated pulse width modulated solenoid valve. When the solenoid is energized, the purge valve is open, allowing the fuel vapor to enter the intake manifold. When the valve is de-energized, the purge valve is closed.

#### EVAPORATIVE SYSTEM

Gasoline vapors from the fuel tank flow into the tube labeled "FROM FUEL TANK" (Figure 1.3-1). These vapors are absorbed into the granulated carbon. The canister is purged (by electronic control module control) when the engine has been running for a specified amount of time. Air is drawn into the canister through the air inlet port (Figure 1.3-1). The air mixes with the vapor and the mixture is drawn into the intake manifold.

#### OPERATION

The electronic control module operates a pulse width modulated solenoid valve, which controls intake manifold vacuum to the charcoal canister. The solenoid is opened and closed 16 times a second (16 HZ) to meter the purge flow. This is electronic control module controlled, and may occur only during "Closed Loop" fuel control operation. The higher the air flow the more purge flow is allowed. The Tech 1 diagnostic tool has the ability to display the pulse width modulated control signal, in percentage of duty cycle "ON-Time." Zero percent (0%) would indicate the canister is NOT being purged of fuel vapor, 100% would indicate maximum purge is taking place.

The electronic control module turns "ON" the solenoid valve and allows purge when:

- Engine coolant temperature is more than 80°C.
- Fuel control system is operating in "Closed Loop" mode.

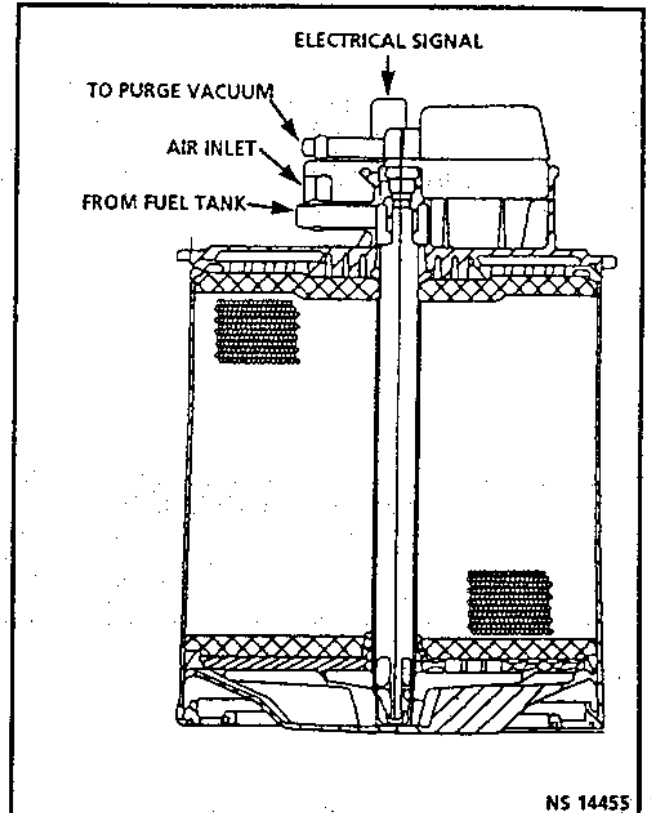

Figure 1.3-1 Vapor Canister

- Vehicle speed is more than 21 km/h. When energized vehicle speed criteria changes to keep purge system active down to 9 km/h.
- Throttle position is more than 2%. Once energized, throttle position will not be a factor unless more than 99%. Then the wide open throttle indicator will de-energize the canister purge solenoid.

#### RESULTS OF INCORRECT OPERATION

- Poor idle, stalling and poor driveability can be caused by:
  - Malfunctioning purge solenoid.
  - Damaged canister.
  - Hoses split, cracked and/or not connected to the proper tubes.
  - Pinched or plugged hose.

#### VISUAL CHECK OF CANISTER

- Solenoid properly mounted and O-ring in place.
- Cracked or damaged, replace canister.
- Fuel leaking from bottom of canister, replace canister and check hoses and hose routing.

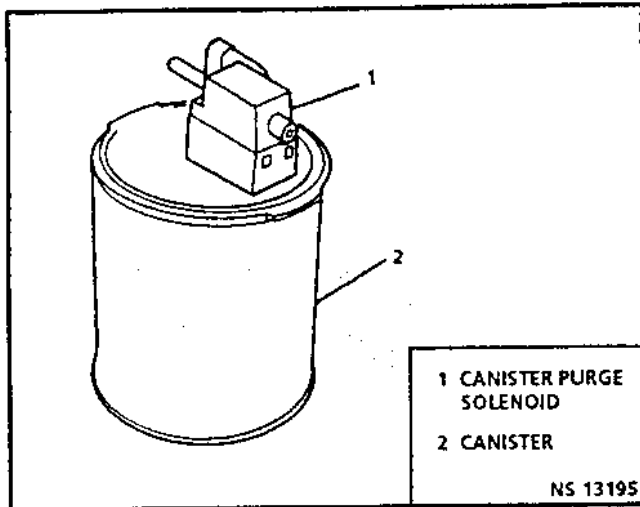
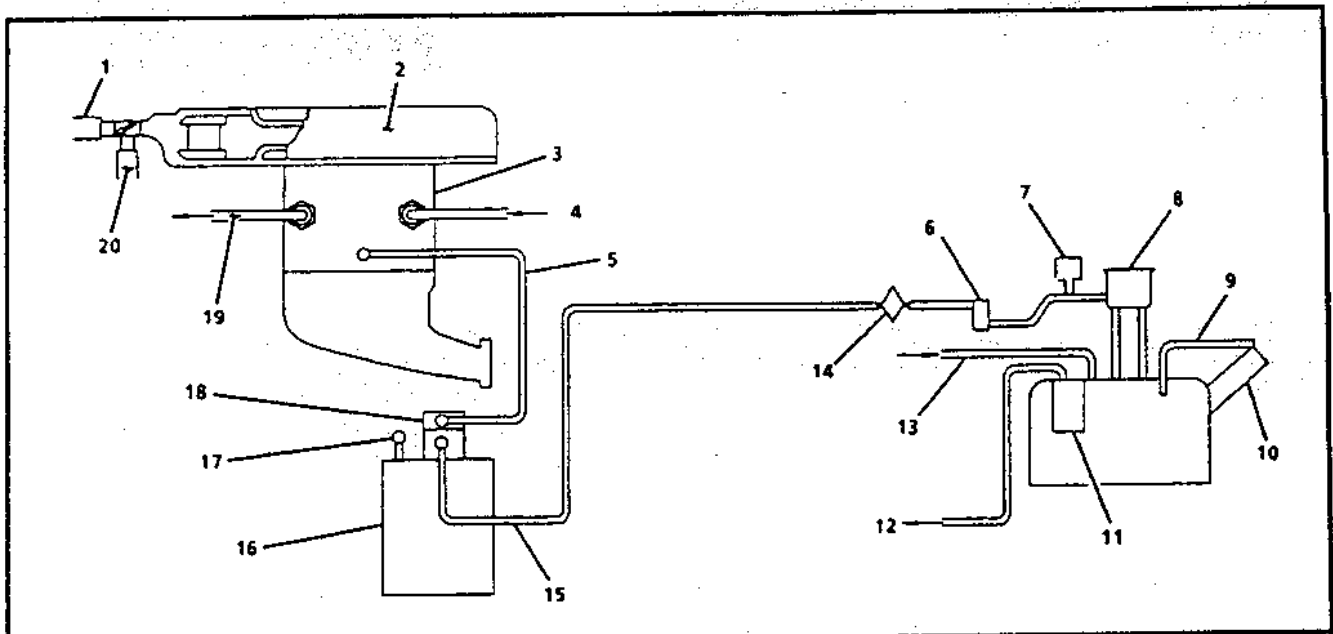

Figure 1.3-2 Canister Purge Solenoid



- |                                |  |
|--------------------------------|--|
| 1 COLD AIR INTAKE              | 11 ELECTRIC FUEL PUMP                            |
| 2 AIR FILTER                   | 12 FUEL INLET TO THROTTLE BODY INJECTION UNIT    |
| 3 THROTTLE BODY INJECTION UNIT | 13 FUEL RETURN FROM THROTTLE BODY INJECTION UNIT |
| 4 FUEL SUPPLY                  | 14 TANK PRESSURE CONTROL VALVE                   |
| 5 CANISTER PURGE               | 15 FUEL TANK VENT TO CANISTER                    |
| 6 ROLLOVER FUEL SHUT OFF VALVE | 16 CANISTER                                      |
| 7 TANK PRESSURE RELIEF VALVE   | 17 FRESH AIR IN                                  |
| 8 SEPARATOR                    | 18 CANISTER ELECTRONIC VALVE                     |
| 9 AIR OUTLET PIPE              | 19 FUEL RETURN                                   |
| 10 FILL PIPE                   | 20 HOT AIR INTAKE                                |

NS 14449

Figure 1.3-3 Evaporative Emission Control System

## 1.4 DIRECT IGNITION SYSTEM

### GENERAL DESCRIPTION

#### SYSTEM OPERATION

The direct ignition system does not use the conventional distributor and ignition coil. This ignition system consists of two separate ignition coils, a direct ignition system ignition module and crankshaft sensor as well as the related connecting wires and the electronic spark timing portion of the electronic control module (Figure 1.4-1). It has no moving parts, and so requires no maintenance. It also has no adjustment, as ignition timing is totally electronically controlled.

A distributorless ignition system such as this one uses a "waste spark" method of spark distribution. Each cylinder is paired with the cylinder that is opposite it (1-4 or 2-3). The spark occurs simultaneously in the cylinder coming up on the compression stroke and in the cylinder coming up on the exhaust stroke.

The cylinder on the exhaust stroke requires very little of the available energy to fire the spark plug. The remaining energy will be used as required by the cylinder on the compression stroke. The same process is repeated when the cylinders reverse roles.

It is possible in a no load condition for one plug to fire, even though the spark plug lead from the same coil is disconnected from the other spark plug. The disconnected spark plug lead acts as one plate of a capacitor, with the engine being the other plate. These two "capacitor plates" are charged as a current surge (spark) jumps across the gap of the connected spark plug. The "plates" are then discharged as the secondary energy is dissipated in an oscillating current across the gap of the spark plug still connected. Because of the direction of current flow in the primary winding, and thus in the secondary winding, one plug will fire from the center electrode to the side electrode while the other will fire from side electrode to center electrode.

This system utilizes the electronic spark timing signal from the electronic control module to control spark timing. Under 500 revolutions per minute, the direct ignition system module controls spark timing (ignition module timing mode) and over 500 revolutions per minute, the electronic control module controls spark timing (electronic spark timing mode).

To properly control ignition timing, the electronic control module relies on the following information:

- Engine speed (revolutions per minute).
- Engine load (manifold absolute pressure).
- Atmospheric (barometric) pressure.
- Engine coolant temperature.
- Intake air temperature.
- Crankshaft position.

### ELECTRONIC SPARK TIMING

#### Figure 1.4-1

Following is a brief description for each of the four electronic spark timing circuits, between the ignition module and electronic control module.

- **Crankshaft Reference Input Signal - Circuit 42.**

The crankshaft sensor generates signals to the ignition module, which results in reference pulses being sent to the electronic control module. The electronic control module uses these signal pulses to calculate crankshaft position and engine speed and injector pulse width.

- **Reference Low - Circuit 58.**

This wire is grounded only through the module and ensures that the ground circuit has no voltage drop between the ignition module and the electronic control module, which could affect performance.

- **Bypass Mode Control - Circuit 39.**

At about 500 revolutions per minute, the electronic control module applies 5 volts to this circuit to switch spark timing control from the direct ignition system module to the electronic control module. This circuit could be considered a "mode control" circuit for the ignition system. The two modes of ignition system operation are ignition module control mode, sometimes called the "bypass mode," and electronic control module mode, sometimes called "electronic spark timing mode."

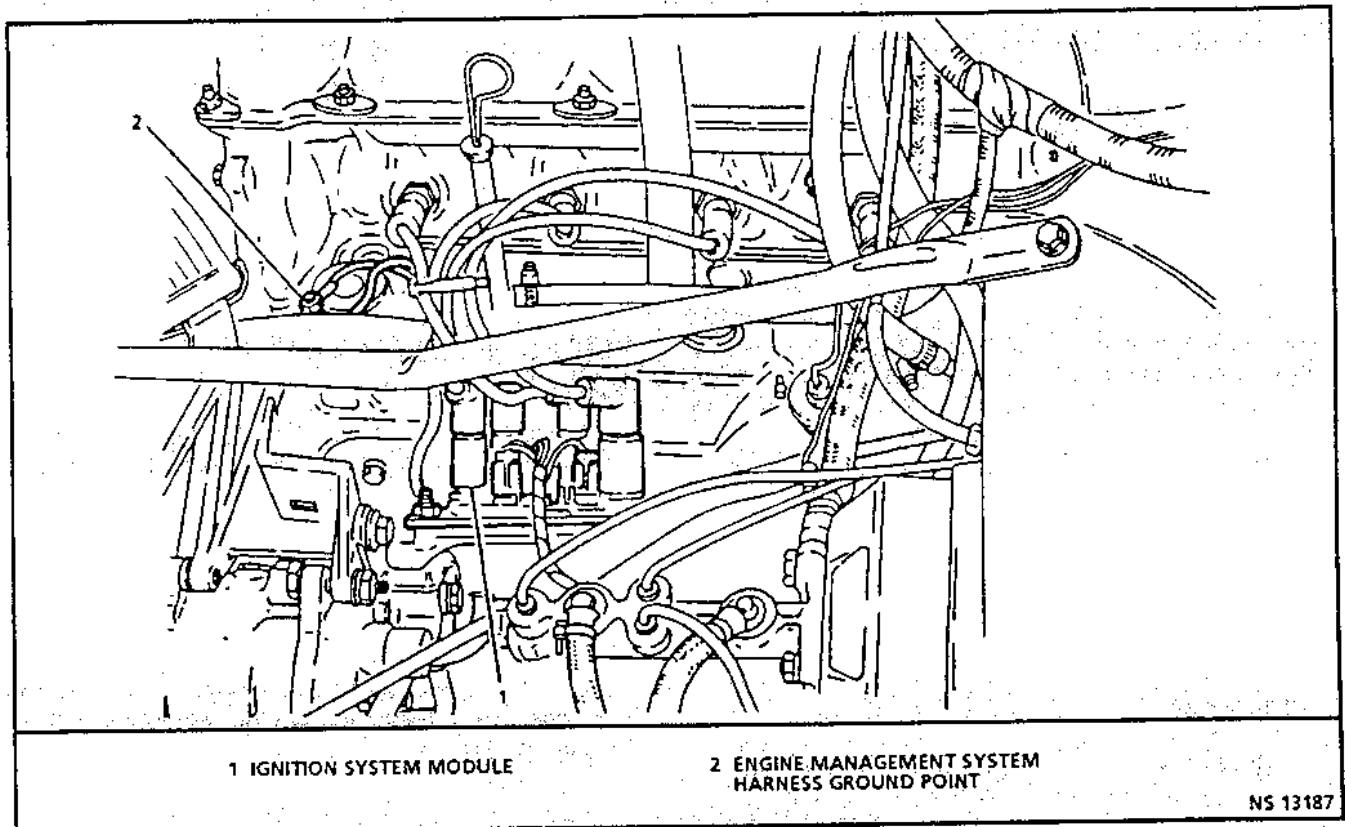

1 IGNITION SYSTEM MODULE

2 ENGINE MANAGEMENT SYSTEM HARNESS GROUND POINT

NS 13187

Figure 1.4-1 Ignition Coils, Wires, Module and Ground Points

- **Electronic Spark Timing Output - Circuit 40.**

The direct ignition system module sends a reference signal to the electronic control module when the engine is cranking. While the engine is under 500 revolutions per minute, the direct ignition system module controls the ignition timing. When the engine speed exceeds 500 revolutions per minute, the electronic control module applies 5 volts to the bypass mode control circuit to switch the ignition system to electronic control module control (electronic spark timing mode). When the ignition system is operating in the "electronic spark timing mode," the output signal on Circuit 40 from the electronic control module to the ignition module is totally responsible for spark timing and ignition dwell time.

### SYSTEM COMPONENTS

#### Crankshaft Sensor

*Figures 1.4-2 and 1.4-3*

This system uses a magnetic crankshaft sensor mounted within approximately 1 mm of the crankshaft reluctor. The reluctor is a special wheel attached to the front of the crankshaft with seven slots machined into it, six of which are equally spaced (60° apart). A seventh slot is spaced 10° from one of the other slots and serves

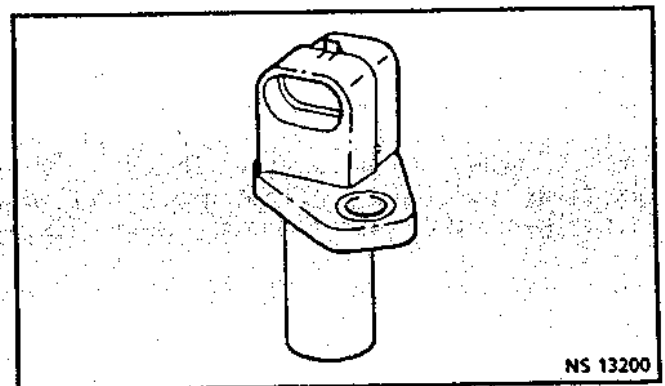

NS 13200

Figure 1.4-2 Crankshaft Sensor

to generate a "synchronization-pulse." As the reluctor wheel rotates as part of the crankshaft, the slots change the magnetic field of the sensor, creating an induced voltage pulse.

Based on the crank sensor pulses, the direct ignition system module sends reference signals to the electronic control module which are used to indicate crankshaft position and engine speed. The direct ignition system module will continue to send these reference pulses to the electronic control module at a rate of one per each 180° of crankshaft rotation.

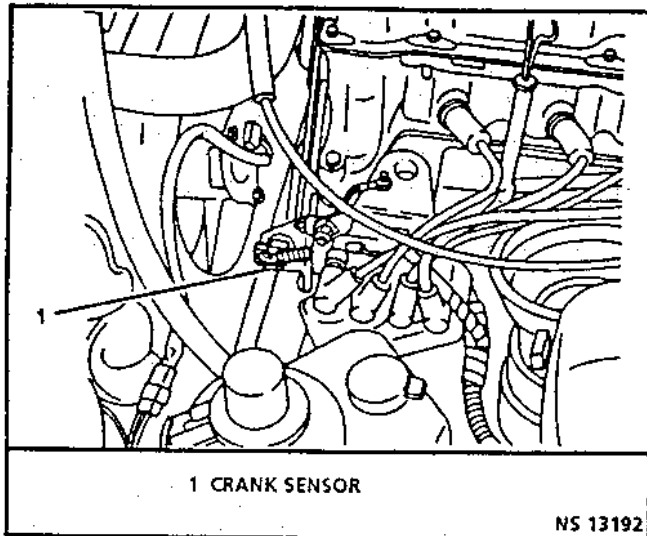

Figure 1.4-3 Crankshaft Sensor Location View

The electronic control module will activate the fuel injector based on the recognition of each reference pulse sent from the ignition module. By comparing the time between pulses, the direct ignition system module can recognize the pulse representing the seventh slot (synchronization pulse) which starts the calculation of ignition coil sequencing.

The second crank pulse following the "synchronization-pulse" signals the direct ignition system module to fire the #2/3 ignition coil and the fifth crank pulse signals the module to fire the #1/4 ignition coil.

### Ignition Coils

Two separate coils are mounted to the module assembly. Each coil provides the spark for two plugs simultaneously (Waste Spark Distribution). Each coil can also be replaced separately (Figure 1.4-4).

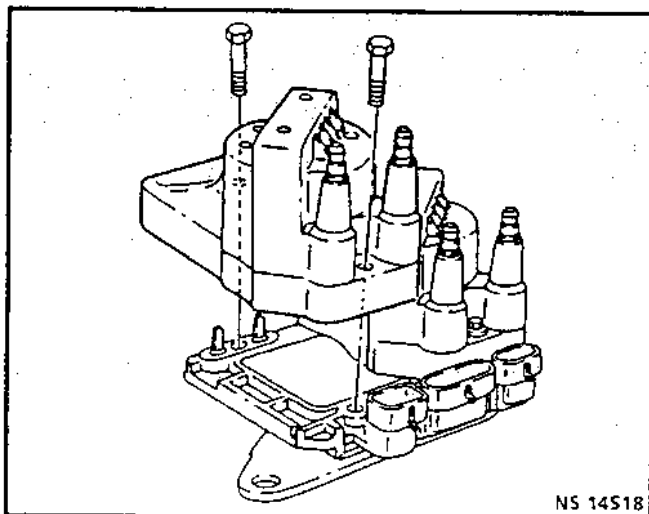

Figure 1.4-4 Ignition Coil Replacement

### Direct Ignition System Module

The direct ignition system module monitors the crank sensor signals and based on these signals sends a reference signal to the electronic control module so that correct spark and fuel injector control can be maintained during all driving conditions. During cranking, the direct ignition system module monitors the "synchronization-pulse" to begin the ignition firing sequence. Below 500 revolutions per minute the ignition module controls spark advance by triggering each of the two coils at a predetermined interval based on engine speed only. Above 500 revolutions per minute the electronic control module controls the spark timing (electronic spark timing mode) and compensates for all driving conditions. The direct ignition system module must receive a "sync-pulse" and then a crank signal in that order to enable the engine to start.

The direct ignition system module has no moving parts and therefore is not repairable. If the module is found to be defective it can be replaced. When a module is replaced, the remaining direct ignition system components including the ignition coils (Figure 1.4-4) must be transferred to the new module.

## DIAGNOSIS

### SYMPTOM DIAGNOSIS

An open or ground in the electronic spark timing output circuit will result in the engine continuing to run, but in ignition module control mode at a calculated timing value and the "Check Engine" light will not be "ON." If the electronic spark timing output circuit fault is still present the next time the engine is restarted, a Code 42 will be set and the engine will operate in the ignition module control mode. This may cause poor performance and reduced fuel economy.

### How Code 42 Is Determined

The electronic spark timing output circuitry in the electronic control module issues electronic spark timing output pulses *anytime* crankshaft reference signal input pulses are being received. When the ignition system is operating in the ignition module mode (no voltage on the bypass mode control circuit), the ignition module grounds the electronic spark timing pulses sent from the electronic control module. The ignition module will remove the ground path for the electronic spark timing pulses only after switching to the electronic spark timing mode. *(The electronic control module commands the switching between ignition module and electronic spark timing modes, via the bypass mode control circuit to the ignition module.)*

## 1-40 ENGINE MANAGEMENT SYSTEMS 1.7L THROTTLE BODY INJECTION

The electronic control module monitors its electronic spark timing output, and expects to see no pulses on the electronic spark timing output circuit when it has not supplied the 5 volts on the bypass mode control circuit.

When the correct engine speed for electronic spark timing operation is reached (*more than 500 revolutions per minute*), the electronic control module applies 5 volts to the bypass mode control circuit, and the electronic spark timing pulses should no longer be grounded by the ignition module. The electronic control module constantly monitors its electronic spark timing output circuit, and should "see" the electronic spark timing pulses only when in the "electronic spark timing mode."

If electronic spark timing output circuit is open, the electronic control module will detect electronic spark timing output pulses while attempting to start the engine (*in the ignition module mode*) due to the ignition module not being able to ground the electronic spark timing pulses. Three things will occur: 1) a Code 42 will set; 2) the electronic control module will not apply 5 volts to the bypass mode control circuit, and 3) the engine will start and run in the ignition module control mode.

If electronic spark timing output circuit is grounded, the electronic control module would not detect a problem until the change to electronic spark timing mode happens. When the electronic control module applies 5 volts to the bypass mode control circuit, the ignition module will switch to the electronic spark timing mode. If the electronic spark timing output circuit is grounded, there would be no electronic spark timing pulses for the ignition module to trigger the ignition coils with and the engine may falter. The electronic control module will quickly revert back to the ignition module mode (*turn "OFF" the 5 volts on the bypass mode control circuit*). Code 42 will set, and the ignition system will operate in the ignition module control mode until the fault is corrected and the engine is stopped and restarted.

If bypass mode control circuit is open -OR- grounded, the ignition module can not switch to the electronic spark timing mode. In this case, the electronic spark timing pulses will stay grounded by the ignition module, and Code 42 will be set. The engine will start and run in the ignition module mode.

### Results of Incorrect Operation

An open or ground in the electronic spark timing or bypass mode control circuit will set a Code 42. If a fault occurs in the electronic spark timing output circuit when the engine is running, the engine may falter or quit running but will restart and run in the ignition module mode. A fault in either circuit will force the ignition system to operate on ignition module mode timing, which will result in reduced performance and fuel economy.

The electronic control module uses information from the manifold absolute pressure and coolant temperature sensors in addition to revolutions per minute to calculate the main spark advance values as follows:

|   |                |
|---|----------------|
| High revolutions per minute .....   | = more advance |
| Low manifold absolute pressure volts<br>( <i>low engine load</i> ) .....      | = more advance |
| Cold engine .....   | = more advance |
| Low revolutions per minute .....  | = less advance |
| High manifold absolute pressure volts...<br>( <i>high engine load</i> ) ..... | = less advance |
| Hot engine .....  | = less advance |

Therefore, detonation could be caused by incorrect low manifold absolute pressure sensor output voltage or incorrect high resistance in the coolant temperature sensor circuit. Poor performance could be caused by incorrect high manifold absolute pressure output voltage or incorrect low resistance in the coolant temperature sensor circuit.

## 1.9 ELECTRONIC CONTROL MODULE-CONTROLLED INTAKE MANIFOLD ELECTRIC HEATER

### GENERAL DESCRIPTION

An intake manifold electric heating element (Figure 1.9-1) is used on the 1.7L throttle body injection engine to provide a source of rapid heat to the engine intake system during cold operation. Rapid heating is desirable because it provides quick fuel evaporation, and a more uniform fuel distribution which aids cold driveability, and reduced exhaust emissions.

The heater is self-current limiting; as its temperature increases, its resistance increases. Increased resistance prevents thermal overheating, with a possible resultant short to ground.

### OPERATION

The manifold heater, mounted into the bottom of the intake manifold directly under the throttle body injection unit, is switched "ON" and "OFF" by the electronic control module (Figure 1.9-2).

The electronic control module switches "ON" the heater by grounding the manifold heater relay control circuit when all the following conditions exist:

- Coolant temperature sensor input is less than 65°C.  
AND
- Intake air temperature sensor input is less than 80°C.  
AND
- Battery voltage is greater than 8 volts.

The above conditions are present in a cold, running engine with minimal accessory load.

The electronic control module switches "OFF" the manifold heater after it has been "ON," if any of the following conditions exist:

- Coolant temperature sensor input is greater than or equal to 65°C.  
OR
- Battery voltage is less than 6 volts
- Intake air temperature input is greater than 80°C.

The above conditions are present in a warm engine and/or with a heavy electrical accessory load.

### SPECIAL NOTE

The manifold heater draws a large amount of electrical current when first energized, as much as 60 amps for a few seconds. The current requirements quickly reduce as the heating element warms and stabilizes at approximately 20 amps. The manifold heater is also energized when the electronic control module is operating in the "Diagnostic Mode." This is described in "Diagnosis," Section "2".

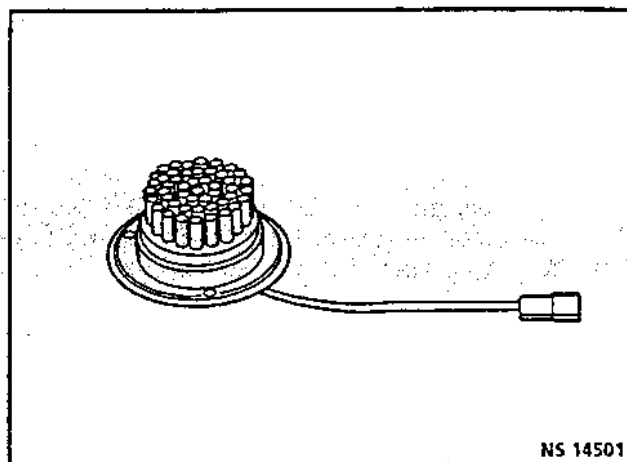

Figure 1.9-1 Intake Manifold Heater

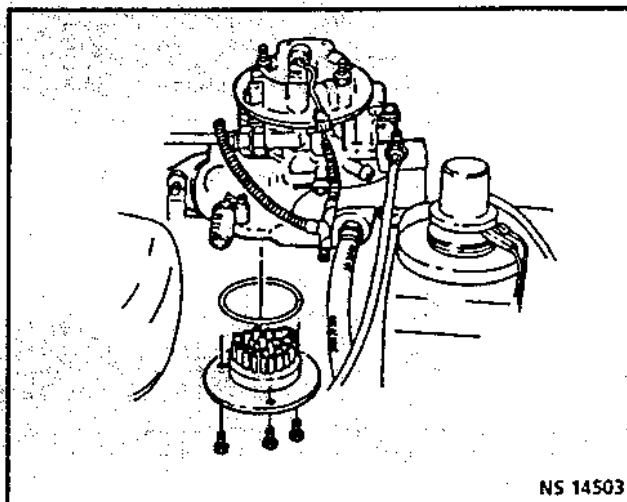

Figure 1.9-2 Intake Manifold Heater Location View



### 1.10 ELECTRONIC CONTROL MODULE-CONTROLLED AIR CONDITIONING

#### GENERAL DESCRIPTION

To improve idle quality and wide open throttle performance, the air conditioning compressor is controlled by the electronic control module (Figure 1.10-1).

The system is made up of an air conditioning cycling switch, high-pressure switch, high coolant temperature switch, air conditioning compressor clutch control relay (relay 2), control unit relay (relay 1), condenser fan relay (relay 3), blower switch, the compressor and instrument panel switch.

The electronic control module monitors the air conditioning evaporative temperature cycling switch, and the air conditioning instrument panel switch and regulates the air conditioning compressor load on the engine through the air conditioning compressor clutch control relay.

The electronic control module can anticipate the air conditioning compressor's load and will remove or delay adding the load if:

- Throttle position sensor is above a set value or angle.
- Coolant temperature sensor is above a set value or temperature.
- The load already on the engine is above a set value based upon vehicle speed and throttle position angle.
- The engine exceeds a certain speed (high revolutions per minute).
- The engine speed is too low to prevent a condition that could cause the engine to stop.

#### Other Special Conditions:

The electronic control module will de-energize the air conditioning clutch via the air conditioning clutch control relay if the battery voltage is greater than 16.9 volts:

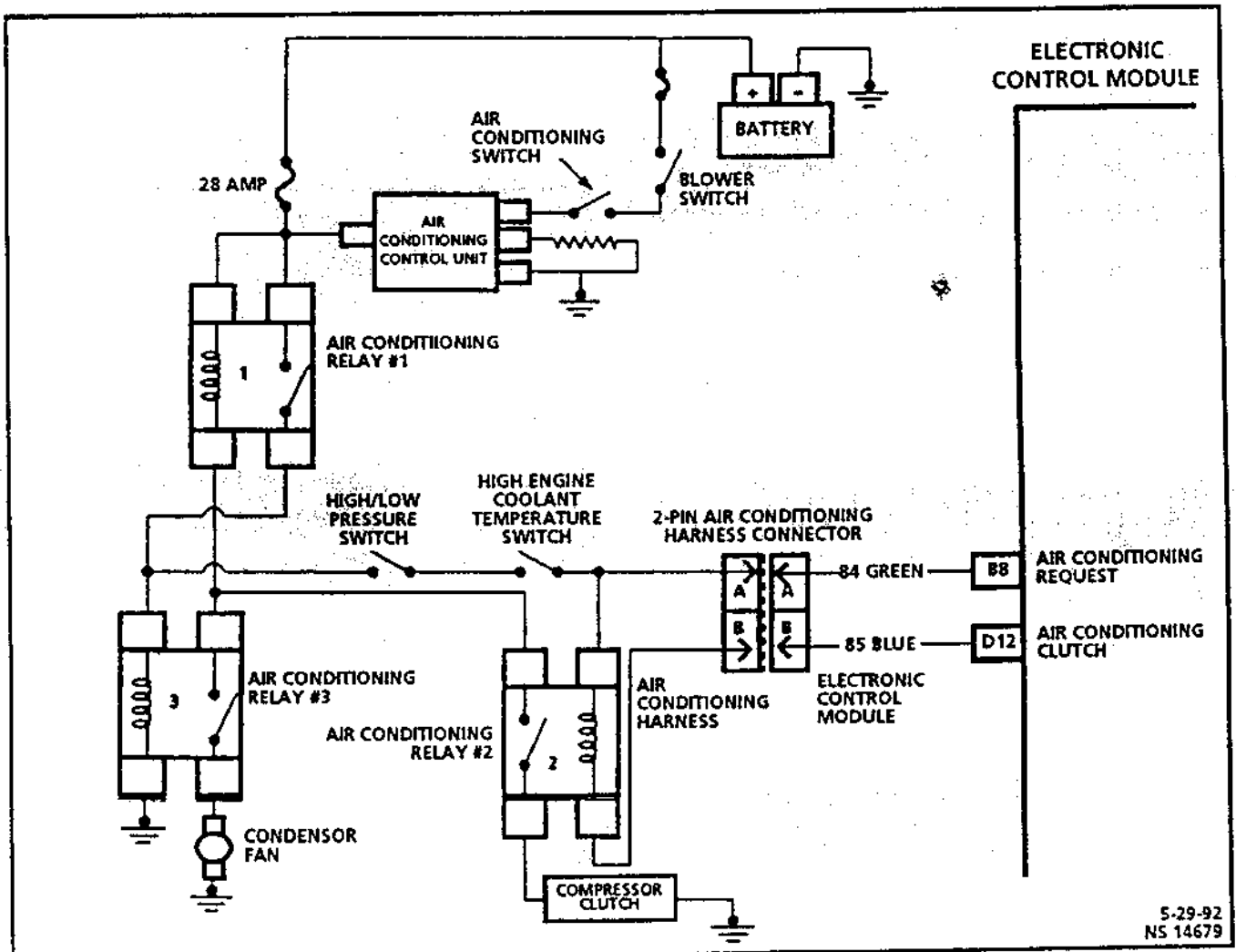

Figure 1.10-1 Electronic Control Module Controlled Air Conditioning Circuit

## 1.13 CRANKCASE VENTILATION SYSTEM

### GENERAL DESCRIPTION

A crankcase ventilation system (Figure 1.13-1) is used to provide more complete scavenging of crankcase vapors. Unlike some ventilation systems, the throttle body injection system does not supply fresh air to the crankcase.

The crankcase ventilation system has two circuits, a primary and secondary circuit. In both circuits the gas and oil vapors from the crankcase are returned to the combustion chambers through an oil separator located on the engine block near the direct ignition system module.

The primary circuit consists of a calibrated orifice fitted into the throttle body injection unit. A small hose runs from this orifice and into the oil separator. A larger (secondary circuit) hose runs from the air cleaner to the oil separator. These hoses make up the two (primary/secondary) circuits of this system.

At idle all crankcase vapors are directed through the primary circuit orifice (small hose), which will be experiencing high manifold vacuum. Under heavy load or wide open throttle conditions, a small amount of the crankcase vapors are passed through the primary system orifice. However, most of the gases pass through the secondary system (large hose) into the air cleaner, through the throttle body injection, and are burned in the combustion chamber.

### RESULTS OF INCORRECT OPERATION

A plugged orifice or hoses may cause:

- Higher than normal idle air control valve steps.
- Oil leaks.
- Oil in air cleaner.
- Sludge in engine.

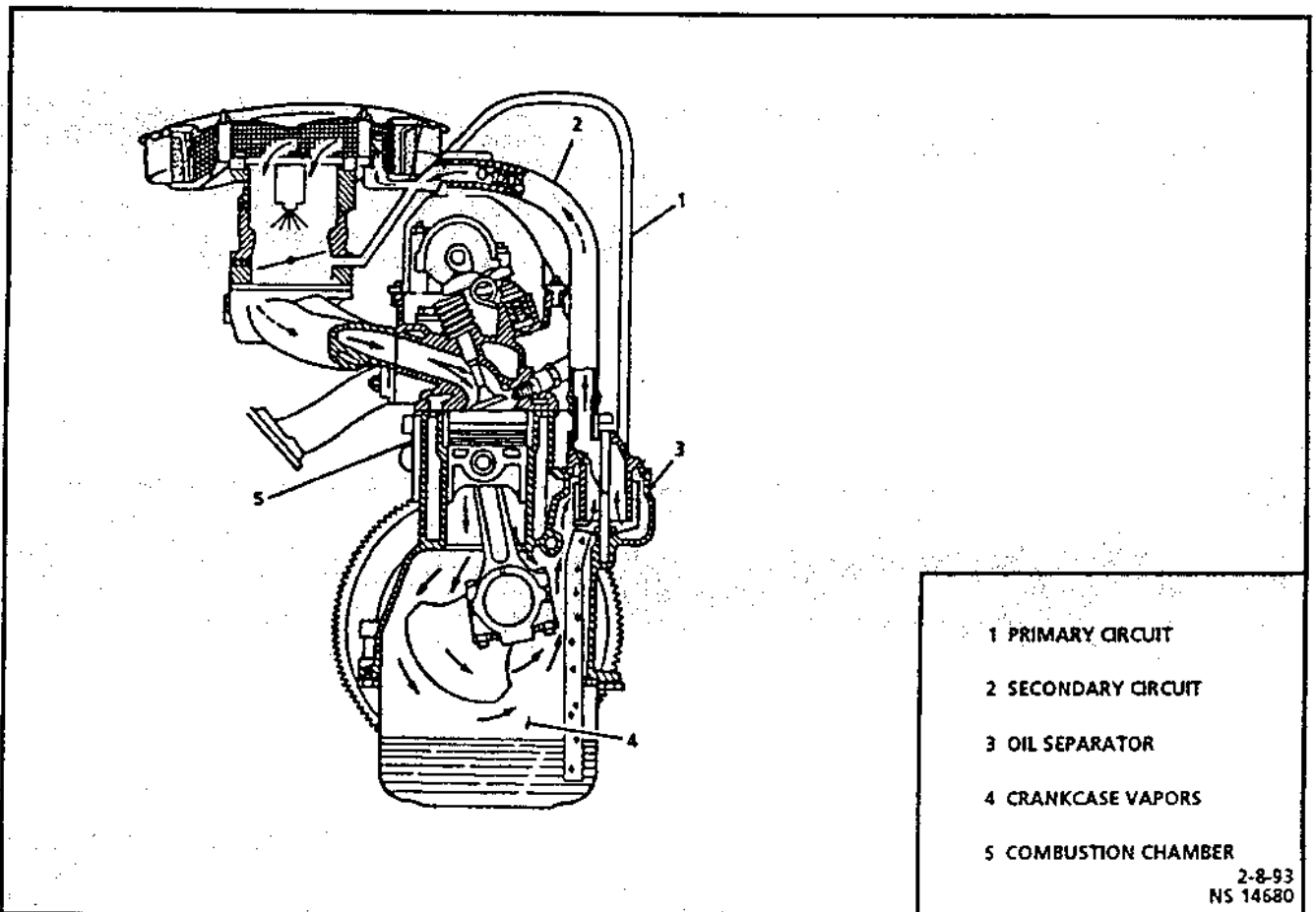

Figure 1.13-1 Crankcase Ventilation System

VAZ SERVICE MANUAL THROTTLE BODY INJECTION NIVA

## 1.14 THERMOSTATIC AIR CLEANER

### GENERAL DESCRIPTION

#### PURPOSE

A heated intake air system is used to give good driveability under varying climatic conditions. By having a uniform inlet air temperature, the fuel system can be calibrated to reduce exhaust emissions and to eliminate throttle valve icing.

#### OPERATION

The THERMOSTATIC air cleaner operates by heated air and a wax pellet motor similar to the one which operates the engine coolant thermostat. Air can enter the air cleaner from outside the engine compartment or from a heat stove built around the exhaust manifold.

- Hot Air Delivery Mode. When the temperature is below 30°C, the wax pellet contracts and the damper door will be shutting off outside air and allowing only heated air from the exhaust manifold to enter the air cleaner.
- Outside Air Delivery Mode. When the temperature is above approximately 55°C, the damper door drops down and only outside air enters the air cleaner.
- Regulating Mode. Between approximately 30°C and 55°C the damper door allows both heated and outside air to enter the air cleaner.

### RESULTS OF INCORRECT OPERATION

- Hesitation during warm-up can be caused by:
  - Heat stove tube disconnected.
  - Door tension spring not operating.
  - Wax pellet not operating.
  - Damper door does not move.
  - Missing air cleaner to throttle body injection seal.
  - Loose air cleaner.
- Lack of power, sluggish, pinging (spark knock or detonation), on a hot engine can be caused by:
  - Damper door does not open to outside air.

### THERMOSTATIC AIR CLEANER FUNCTIONAL CHECK

1. Inspect system to be sure heat stove tube is connected.
2. Check damper door in air cleaner for freedom of movement.
3. Check damper door tension spring is attached, and pulling the damper door to the wax pellet actuator.
4. Check for presence and condition of air cleaner to throttle body injection gasket and cover seal.
5. With air cleaner assembly installed, engine not running, damper door should be open to heat stove air when engine is cold.
6. Start engine. Watch damper door in air cleaner snorkel. When engine is first started, damper door should be closed to outside air. As air cleaner warms up (this will take several minutes depending on temperature), damper door should open slowly to allow outside air in.

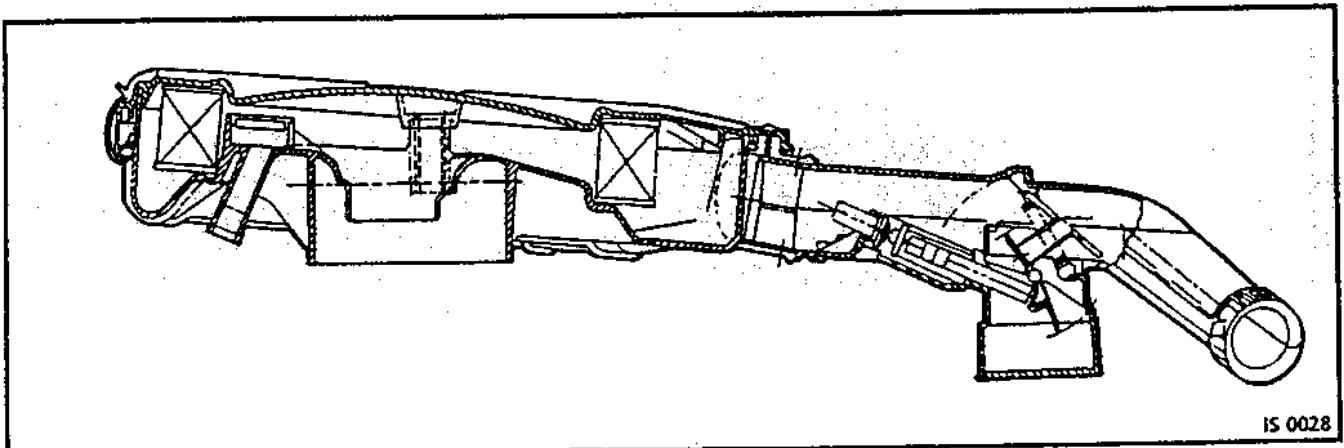

Figure 1.14-1 THERMAC Air Cleaner - Wax Pellet Operated

# **TURBONutter**

Lada Niva 4x4  
Service Manual  
Fuel Injection

This manual and a host of other wonderful Lada Niva documentation is available free of charge at:

<http://www.turbo-nutter.com>

You can do anything you like with this manual except sell it or otherwise make money from it.

While I can't stop you sticking it on your own website I would much prefer you linked to its original location on turbo-nutter.com

You use the information contained with this manual at you own risk. If you're not sure how to do something either don't do it or ask someone who knows about such things. The font of all Lada knowledge can be found at:

<http://www.lada.co.uk/forum>

For Lada parts, advice and general all round Lada wonderfulness these blokes aren't bad:

Lada UK Ltd  
Askew Rigg  
Troutbeck  
Penrith, Cumbria  
CA11 0SZ  
United Kingdom

T: +44 (0) 17 6877 9794  
F: +44 (0) 17 6877 9197  
E: [alan@lada.co.uk](mailto:alan@lada.co.uk)  
W: <http://www.lada.co.uk>

Lada Parts Australia P/L  
42 Aerodrome Road  
Caboolture  
Queensland  
4510  
Australia

T: +61 7 5495 5100  
F: +61 7 5495 5152  
E: [andy@ladaparts.com](mailto:andy@ladaparts.com)  
W: <http://www.ladaparts.com>

## 2. DIAGNOSIS

### INTRODUCTION

Diagnosing the electronic fuel injection and engine management system is fairly straightforward if you use a sound diagnostic procedure.

The first and foremost order of importance, for diagnosing a problem with any type of system, is to understand how that system is supposed to normally operate. Whether it is an automotive system, a heating system for a building, or even a human biological system like your heart or lungs, before attempts are made to repair a problem, it is crucial to understand what is normal and what is not normal.

In other words, to be effective in diagnosing and repairing problems with the electronic fuel injection and engine management system, it is important that you possess a good working knowledge of the system.

Having the proper diagnostic tools and reference materials available, and attendance at training schools is a good method for planning to succeed when diagnosing problems or malfunctions with the engine management system.

This manual has a section specifically written to help in understanding how the system normally operates. The first section of this manual, Section "1", titled "General Description and System Operation," is a good place to begin your understanding of normal system and component operation. Make sure you take the time to read the material contained at least once.

### The Importance of Mechanical Systems

Don't forget, underneath all the wiring, electronics, sensors, and actuators is a basic internal combustion engine. The fuel injection and engine management system assumes that all of the engine's mechanical systems are functioning properly. As a reminder, here are a few "basic engine" items that might cause conditions that could be blamed incorrectly on the "electronics," the engine management system:

- Low compression
- Vacuum leaks
- Exhaust system restrictions
- Incorrect valve timing caused by worn parts or incorrect assembly
- Poor quality fuel
- Ignored regular maintenance intervals

### The Importance of Having the Special Diagnostic Tools

There are certain special diagnostic tools that are called out in the diagnostic procedures and charts. These tools are designed for specific diagnostic uses, and the service manual procedures and charts that call for their use are written to require having these tools available. If the special diagnostic tools are not used where indicated, most efforts to accurately diagnose problems with the engine management system will be extremely difficult, if not impossible. These special diagnostic tools have been carefully designed and selected, and are available as a diagnostic tool kit through Kent-Moore SPX Corporation. Address, FAX, and phone numbers are supplied in Section 6 - "Special Tools," of this manual.

As to special tools, it is important to remember that none of the special diagnostic tools will make you into a diagnostic genius. No tool will ever replace human intellect. Tools can't perform a diagnosis for you, and they don't eliminate the need for diagnostic charts and service procedures. All of the special diagnostic tools are just that—tools.

Tools are used to help perform various tasks. Some tools, such as the Tech 1 diagnostic tool or the digital volt-ohm-amp multimeter, allow us a way to examine what is happening in an electrical or electronic circuit. The Tech 1 diagnostic tool is by itself a small handheld computer, and communicates with the electronic control module. The Tech 1 allows us a way of "seeing" what the electronic control module is interpreting from its various input signals, and a "window" to observe what commands are being sent to the various devices that are controlled and operated by the electronic control module.

### Knowledge required

It is *NOT* required that you fully understand how electronics and computers operate. What is required is a basic working knowledge of applied electrical theory, such as voltage, current, resistance, and what happens in an "open" circuit, and what happens in a "shorted" circuit. You should also be familiar with interpreting a simple wiring diagram. Also, you should be familiar with how to use a digital volt-ohm-amp multimeter in various situations. Of course, it is assumed that you have a good understanding of how a basic automotive engine operates.

## 2-2 ENGINE MANAGEMENT SYSTEMS 1.7L THROTTLE BODY INJECTION

The engine used in this vehicle has controls to reduce exhaust emissions while maintaining good driveability and fuel economy.

An electronic control module is the heart of this control system and has sensors used to get information about engine operation and about the various systems it controls. Details of basic operation are covered in Section "1", "General Description and System Operation."

The electronic control module has the ability to do some diagnosis of the engine management. When it finds a problem, it turns "ON" a "CHECK ENGINE" light on the instrument panel, and a trouble code will be stored in the electronic control module memory. *This does not mean that the engine should be stopped right away, but that the cause of the light coming "ON" should be checked as soon as reasonably possible.*

### DIAGNOSIS PROCEDURE

This portion of Section "2", "Diagnosis" of the manual is divided into 5 parts. They are:

**INTRODUCTION.** This contains general information about how to use this section.

**"A" SECTION AND "A-" CHARTS.** This is where all diagnostic procedures begin. It contains: the all-important "DIAGNOSTIC CIRCUIT CHECK"; charts about the "Check Engine" light; what to do if the engine will not run; and other general charts.

**TROUBLE CODE CHARTS.** If the DIAGNOSTIC CIRCUIT CHECK reveals a trouble code set in the electronic control module's memory, this is where the individual trouble codes are diagnosed. If more than one trouble code is stored, always start with the lowest number before going to the next higher trouble code.

**"B" SECTION. DRIVEABILITY SYMPTOMS.** If no trouble code is stored, or a code is stored but proves to be only an intermittent condition, this part will help the mechanic find the problem. Again, all diagnostic procedures must begin with the DIAGNOSTIC CIRCUIT CHECK.

**"C" SECTION AND "C-" CHARTS (Component Systems).** This part contains general remove and replace information about the individual components in the engine control system. It also contains service information about those components. This is where you would look to find information on: the ignition system; intake manifold electric heater system; the fuel injector; the air conditioning electrical control system; and so on.

## 2.1 DIAGNOSTIC PRECAUTIONS

The following requirements must be observed when working on vehicles:

1. Before removing any electronic control module system component, disconnect the battery ground cable.
2. Never start the engine without the battery being solidly connected.
3. Never separate the battery from the on board electrical system while the engine is running.
4. When charging the battery, disconnect it from the vehicle's electrical system.
5. Never subject the electronic control module to temperatures above 80°C, i.e. paint oven. Always remove control unit first if this temperature is to be exceeded.
6. Ensure that all cable harness plugs are connected solidly and that battery terminals are thoroughly clean.
7. The engine management system harness connectors are designed to fit only one way; there are indexing tabs and slots on both halves of the connector. Forcing the connector into place is not necessary if it is installed with the proper orientation. Failure to match the indexing tabs and slots on the connector can cause damage to the connector, the module, or other vehicle components or systems.
8. Never connect or disconnect the electronic control module connectors when the ignition is switched "ON."
9. Before attempting any electric arc welding on the vehicle, disconnect the battery leads and the electronic control module connectors.
10. When steam cleaning engines, do not direct the steam cleaning nozzle at electronic control module system components. If this happens, corrosion of the terminals can take place.
11. Use only the test equipment specified in the diagnostic charts; other test equipment may give incorrect results or damage good components.
12. Make all voltage measurements using a digital voltmeter with an internal impedance rating of at least 10 million ohms per volt (10 MΩ/volt).
13. When a test light is specified, a "low-power" test light must be used. Do not use a high-wattage test light (i.e.: Headlight). While a particular brand of test light is not suggested, a simple check on any test light will ensure it is safe for electronic control module circuit testing. Connect an accurate ammeter (such as the high-impedance digital multimeter) in series with the test light, and power the test light-ammeter circuit with the vehicle battery.

If the ammeter indicates *less* than 1/4 amp current flow (.25 A or 250 ma), the test light is **SAFE** to use.

If the ammeter indicates *more* than 1/4 amp current flow (.25 A or 250 ma), the test light is **NOT SAFE** to use.

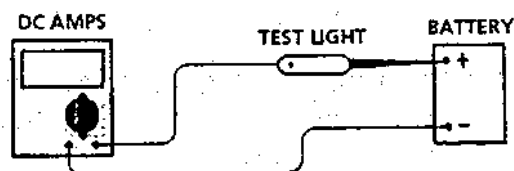

14. Electronic components used in control systems are often designed to carry very low voltage, and are very susceptible to damage from electrostatic discharge. It is possible for less than 100 volts of static electricity to cause damage to some electronic components. By comparison, it takes as much as 4,000 volts for a person to even feel the zap of a static discharge.

There are several ways for a person to become statically charged. The most common methods of charging are by friction and by induction. An example of charging by friction is a person sliding across a car seat, in which a charge of as much as 25,000 volts can build up. Charging by induction occurs when a person with well insulated shoes stands near a highly charged object and momentarily touches ground. Charges of the same polarity are drained off, leaving the person highly charged with the opposite polarity. Static charges of either type can cause damage, therefore, it is important to use care when handling and testing electronic components.

**NOTICE:** To prevent possible Electrostatic Discharge damage:

- Do Not touch the electronic control module connector pins or soldered components on the electronic control module circuit board. Never disassemble the electronic engine control module metal case, except for the calibrator cover.
- When handling an engine calibrator, do not remove the integrated circuit from carrier.

## 2-4 ENGINE MANAGEMENT SYSTEMS 1.7L THROTTLE BODY INJECTION

### 2.2 DIAGNOSTIC GENERAL DESCRIPTION

The diagnostic charts and functional checks in this manual are designed to locate a faulty circuit or component through logic based on the process of elimination. The charts assume the vehicle functioned correctly at the time of assembly and there are no multiple failures.

The electronic control module performs a continual self-diagnosis on certain control functions. This diagnostic capability is aided by the diagnostic procedures in this manual. The electronic control module's language for communicating the source of a malfunction is a system of diagnostic codes. The codes are two digit numbers that range from 12 to 55. When a malfunction is detected by the electronic control module, a code is stored/logged and the "Check Engine" light is turned "ON."

#### "CHECK ENGINE" LIGHT

The light is in the instrument panel and does the following:

- It tells the driver a problem has occurred and the vehicle should be taken for service as soon as reasonably possible. *It does NOT mean the engine should be stopped.*
- It displays diagnostic "Codes" stored by the electronic control module which help the technician diagnose system problems.

As a bulb and system check, the light will come "ON" with the ignition "ON," and the engine not running. When the engine is started, the light will turn "OFF." If the light remains "ON," the self-diagnostic

system has detected a problem. If the problem goes away, the light will turn "OFF" in most cases after 10 seconds, but a diagnostic code will be stored in the electronic control module's memory.

When the light remains "ON" while the engine is running, or when a malfunction is suspected due to a driveability or emissions problem, a "Diagnostic Circuit Check" must be performed. The procedures for these checks are given in "Diagnostic Charts," Section "2.9A". These checks will expose malfunctions which may not be detected if other diagnostics are performed out of order.

#### INTERMITTENT "CHECK ENGINE" LIGHT

In the case of an "intermittent" problem, the "Check Engine" light will turn "ON" for at least ten (10) seconds and then will turn "OFF." However, the matching code will be stored in the memory of the electronic control module until the battery voltage to the electronic control module has been removed or the Tech 1 diagnostic tool has been used to "clear codes." When unexpected codes appear during the code reading process, one can assume these codes were set by an intermittent malfunction and could be helpful in diagnosing the system.

An intermittent code may or may not re-set. *If it is an intermittent failure, a Diagnostic Code Chart is not used.* Consult the "Diagnostic Aids" on the page facing the diagnostic chart corresponding to the intermittent diagnostic code. "Symptom Charts," Section "2.9B" also covers the topic of "Intermittents." A physical inspection of the sub-system often will reveal the problem.

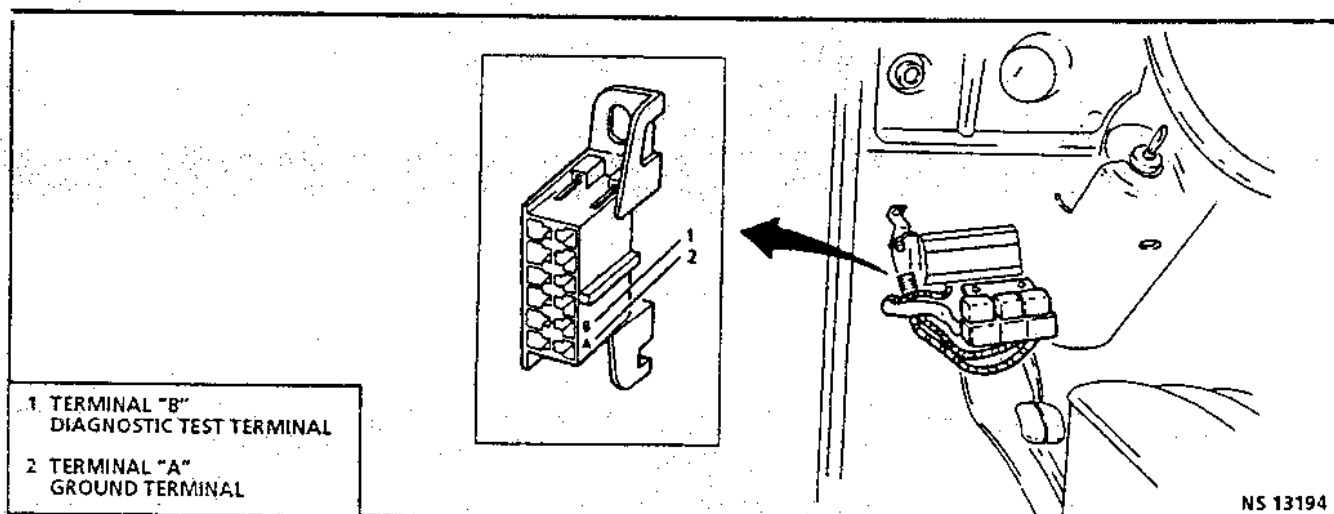

Figure 2.2-1 Assembly Line Data Link Location View



## READING CODES

The provision for communicating with the electronic control module is the assembly line data link connector (see Figure 2.2-1). The assembly line data link connector is used by the assembly plant to receive electronic control module information, and to check the engine before the vehicle leaves the plant. The code(s) stored in the electronic control module's memory can be read either through a Tech 1 (a handheld diagnostic tool plugged into the assembly line data link connector), or by counting the number of flashes of the "Check Engine" light when the diagnostic "test" terminal "B" of the assembly line data link connector is grounded. The assembly line data link connector terminal "B" (diagnostic "test" terminal) is the second terminal from the right of the assembly line data link connector's top row. The terminal is most easily grounded by connecting it to terminal "A" (connected to engine ground), the terminal to the right of terminal "B" on the top row of the assembly line data link connector.

Once terminals "A" and "B" have been connected, the ignition switch must be moved to the "ON" position, with the engine **NOT RUNNING**. At this point, the "Check Engine" light should flash Code 12 three times consecutively. This would be the following flash sequence: "flash, pause, flash-flash, long pause, flash, pause, flash-flash, long pause, flash, pause, flash-flash." Code 12 is not a trouble code. Code 12 merely indicates that the electronic control module's diagnostic system is operating. If Code 12 is NOT indicated, a problem is present within the diagnostic system itself, and should be addressed by consulting the "Diagnostic Circuit Check" chart in "Diagnostic Charts," Section "2.9A".

Following the flashing of Code 12, the "Check Engine" light will flash any trouble codes three times if any diagnostic trouble codes are present, or it will simply continue to flash Code 12. If more than one diagnostic trouble code has been stored in the electronic control module's memory, the codes will flash from the lowest to the highest, with each code displayed three times.

## CLEARING CODES

To clear the codes from the memory of the electronic control module, either to see if the malfunction will occur again or because repair has been completed, there are two methods. Either the electronic control module

power feed must be disconnected for at least ten (10) seconds, or the Tech 1 diagnostic tool also has the ability to "erase" the diagnostic trouble codes from the electronic control module's memory without disconnecting the battery or any fuses. The electronic control module power feed can be disconnected by removing the negative battery terminal. (When the battery terminal is disconnected, other on-board memory data, such as preset electronic radio tuning, is also lost.)

**NOTICE:** To prevent electronic control module damage, the ignition must be "OFF" when disconnecting or reconnecting electronic control module power.

## DIAGNOSTIC DISPLAY MODE

When the diagnostic "test" terminal is grounded (assembly line data link terminal "B" connected to "A") with the ignition "ON" and the ENGINE "STOPPED," the system will enter what is called the "Diagnostic Display" mode. (This can also be done by using the Tech 1 tool in the "F1: Field Service" mode, but with the *engine not running*.) In this mode the electronic control module will:

1. Display a Code 12 by flashing the "Check Engine" light (indicating the system is operating correctly).
2. Display any stored codes by flashing the "Check Engine" light. Each code will be flashed three times, then Code 12 will be flashed again. If no other codes are in the electronic control module's memory, Code 12 will continue to flash as long as the diagnostic display mode is active.
3. Energize the intake manifold heater relay, air conditioning clutch control relay and evaporative canister purge solenoid. This allows checking circuits which may be difficult to energize without driving the vehicle and being under particular operating conditions. These relays and solenoids will remain energized as long as the electronic control module is in the "Diagnostic Display" mode, including the intake manifold electric heater relay, which causes a high electrical load due to the manifold heater operating current.
4. Command the idle air control valve to fully extend to its zero-step position, shutting the idle air passage in the throttle body.

### FIELD SERVICE MODE

If the diagnostic "test" terminal is grounded, or "Field Service" mode is selected from Tech 1 with the **ENGINE RUNNING**, the system will enter the "Field Service" mode. In this mode:

1. The "Check Engine" light will not flash malfunction codes. It will flash in a different manner, telling the technician if the fuel control system is operating in the "Open Loop" or "Closed Loop" mode. If in the "Closed Loop" mode, the flashing of the light will indicate if the exhaust is too rich, too lean, or in control. The explanation of each of the 4 possibilities follow.
  - 1A. Flashing "Open Loop" - The "Check Engine" light will flash "ON" and "OFF" 2.5 times per second (5 times every 2 seconds).
  - 1B. Flashing "Closed Loop" with fuel system operating normally - The "Check Engine" light will flash "ON" and "OFF" at a rate of once per second.
  - 1C. Flashing "Closed Loop" but oxygen sensor input indicates a lean exhaust - The "Check Engine" light will be "OFF" most or all of the time.
  - 1D. Flashing "Closed Loop" but oxygen sensor input indicates a rich exhaust - The "Check Engine" light will be "ON" most or all of the time.
2. The electronic spark timing is fixed at 10° before top dead center when engine revolutions per minute is less than 2,000.
3. The idle air control valve is commanded to a fixed number of steps.
4. Prevent any new diagnostic trouble codes from storing into memory.

See Sections "1.1" or "2.3" for additional information on electronic control module modes of operation.

### ELECTRONIC CONTROL MODULE ADAPTIVE LEARNING ABILITY

The electronic control module has a "learning" ability which allows it to make corrections for minor variations in the engine management system to improve driveability. If the battery is disconnected to clear diagnostic codes or for other repair, the "learning" process resets and begins again. A change may be noted in the vehicle's performance. To "teach" the vehicle, ensure that the engine is at operating temperature. The vehicle should be driven at part throttle, with moderate acceleration and idle conditions until normal performance returns.

**All diagnostic procedures must always begin with the "DIAGNOSTIC CIRCUIT CHECK."**

Diagnostic procedures must begin with the "Diagnostic Circuit Check," which represents an organized approach for identifying system problems.

The "DIAGNOSTIC CIRCUIT CHECK" makes an initial check of the system, and then will direct the mechanic to other charts in the book. It must be used as a starting point for all procedures. The entire book is set up in a specific order, that is, the "DIAGNOSTIC CIRCUIT CHECK" will lead the mechanic to other charts, and those charts may lead to still other charts. **THE SEQUENCE MUST BE FOLLOWED.** The engine control system uses many input signals and controls many output functions. If the correct diagnostic sequence is not followed, incorrect diagnosis and replacement of good parts may happen.

Diagnostic charts incorporate diagnosis procedures using a Tech 1 "Scan" tool where possible. This Tech 1 "Scan" tool is a small hand-held computer in itself. Its job is to give information to a mechanic about what is happening in the engine management system.

The assembly line data link connector is used by the assembly plant to perform end of line tests. This connector can also be used by mechanics to monitor certain inputs and outputs as seen by the electronic control module. The Tech 1 "Scan" tool reads and displays the information (serial data) supplied to the assembly line data link connector from the electronic control module.

## DIAGNOSIS PROCEDURE

In response to the "Check Engine" light or an owner complaint relating to engine performance.

ALL FAULT FINDING SHOULD FOLLOW THE  
DIAGNOSIS CHARTS,

BEGINNING WITH THE

*DIAGNOSTIC CIRCUIT CHECK!*

### DIAGNOSTIC CIRCUIT CHECK

After the visual/physical underhood inspection, the "Diagnostic Circuit Check" in Section "2.9A" is the starting point for all diagnostic procedures or finding the cause of an emissions test failure.

The correct procedure to diagnose a problem is to follow three basic steps.

1. **Are the on-vehicle diagnostics working?** This is determined by performing the "Diagnostic Circuit Check." Since this is the starting point for the diagnostic procedures or finding the cause of an emissions test failure, *always begin here.*

If the on-vehicle diagnostics aren't working, the "Diagnostic Circuit Check" will lead to a diagnostic chart. If the on-vehicle diagnostics are working correctly, the next step is:

2. **Is there a code stored?** If a code is stored, go directly to the numbered code chart. This will determine if the fault is still present. If no code is stored, then:
3. **Observe Serial Data information transmitted by the electronic control module.** This involves reading the information available on the assembly line data link/Serial Data Stream with a Tech 1 "Scan" tool. Information on this tool and the meaning of the various displays can be found in the succeeding paragraphs. Typical data readings under a particular operating condition can be found in: Section "2.9A", "Diagnostic Charts" - Tech 1 "Scan" Tool Typical Data Values.

### 2.3 TECH 1 "SCAN" TOOL DESCRIPTION

#### TECH 1 "SCAN" TOOL

The electronic control module can communicate a variety of information through assembly line data link connector terminal "M". This data is transmitted at a high frequency which requires a Tech 1 "Scan" tool for interpretation.

#### TECH 1 "SCAN" TOOL EXPLANATION

To explain how the "Scan" tool works, let's think for a minute about how a television works. A television is an electronic device that receives and processes information, and sends out information in a form that can be understood by the person watching it. The television receives a signal (from a transmitting station) that is not usable to the person. The television processes it, then sends the signal to a screen. The person can then see the information that the television transmitting station sent out. The "Scan" tool is like the television because it also processes information, sent to it by the electronic control module. The information is sent out of the electronic control module to the assembly line data link connector terminal "M". The "Scan" tool plugs into the assembly line data link connector, and the information is sent to the tool on its cable. The "Scan" tool processes the information, and "sends" the signal to a display screen on the tool. Just like a television, you can select which "station" that you want to see. The difference is instead of seeing the picture on a television, you "see" the display screen, and the "stations" that you can select on a "Scan" tool are the different input and output signals that are being processed by the electronic control module.

#### TECH 1 "SCAN" TOOL USES

The "Scan" tool is a useful and quick way of comparing operating parameters of a poorly operating engine with a known good one. For example, a sensor may shift its value but not set a code. Comparison with a known good vehicle may uncover this problem.

The "Scan" tool allows a quick check of sensors and switches which are inputs to the electronic control module. The electronic control module in the vehicle sends out information to the "Scan" tool at a very fast rate, and the display on the tool can update quicker than a digital voltmeter. The "Scan" tool allows a mechanic to manipulate wiring harnesses or components under the hood while observing the "Scan" readout. This can help in locating intermittent connections.

#### TECH 1 "SCAN" TOOL USE WITH INTERMITTENTS

The Tech 1 "Scan" tool allows manipulation of wiring harnesses or components under the hood with the engine not running, while observing the Tech 1 "Scan" tool readout.

The Tech 1 "Scan" tool can be plugged in and observed while driving the vehicle under the condition when the "Check Engine" light turns "ON" momentarily or when the engine driveability is momentarily poor. If the problem seems to be related to certain parameters that can be checked on the Tech 1 "Scan" tool, they should be checked while driving the vehicle. If there does not seem to be any connection between the problem and any specific circuit, the Tech 1 "Scan" tool can be used to monitor each parameter, watching for a period of time to see if there is any change in the readings that indicates intermittent operation.

The Tech 1 "Scan" tool can capture and store data when the problem occurs, so it can be played back at a slower rate to determine what happened to the system. This is called the "SNAPSHOT" mode.

The Tech 1 "Scan" tool is an easy way to compare the operating parameters of a poorly operating engine with those of a known good one. For example, a sensor may shift in value but not set a diagnostic code. Comparing the sensor's readings with those of a known good vehicle may uncover the problem.

The Tech 1 "Scan" tool saves time in diagnosis and helps to prevent the replacement of good parts. The key to using the Tech 1 "Scan" tool successfully is the technician's ability to understand the system being diagnosed, as well as understanding the Tech 1 "Scan" tool operation and limitations. The technician should read the Tech 1 operating manual to become familiar with the Tech 1 operation.

#### ADDITIONAL TECH 1 FUNCTIONS: "SNAPSHOT"

The Tech 1 tool has the ability to capture and store data parameters as they occur. This data can then be replayed and studied to help you locate current and intermittent problems.

#### "MISCELLANEOUS TESTS"

The Tech 1 "Scan" tool also has the ability to send signals to the electronic control module, instructing the electronic control module to perform various functions or tasks.

This provides a quick way to determine if a device is operational or not. Also included is a command to erase all stored diagnostic trouble codes from the electronic control module's memory.

Briefly stated, one of the Tech 1 menu selections is called "MISCELLANEOUS TESTS." After making that selection, other menu selections can be chosen. Each one is described below.

### OUTPUT TESTS

- Intake manifold heater relay "ON" and "OFF" control. Recommend to observe "SYSTEM VOLTAGE" while commanding the manifold heater to cycle "ON" and "OFF." System voltage should decrease slightly when the manifold heater is "ON," due to large current draw.
- Air conditioning compressor clutch control relay "ON" and "OFF" command can be initiated. Listen for the compressor clutch engagement with the engine at idle and air conditioning controls in the "ON" position.
- "Check Engine" lamp "ON" and "OFF" control.
- Evaporative Emissions storage canister solenoid "ON" and "OFF" control. Recommended to operate engine until fully warm, then observe "CLOSED LOOP FUEL ADJUSTMENT" as "EVAP SOLENOID" is cycled "ON" and "OFF." Percentage of fuel adjustment (XX%) should quickly change as canister is purged of fuel vapors.

### IDLE SYSTEM

- Idle control: To exercise the Idle air control motor, by changing the "desired idle speed" up or down. The idle air control valve should track this command, and engine speed should follow up or down if the idle air control valve is functioning properly.
- Idle reset: To reset the idle air control valve. Should cause the idle air control valve to fully extend to the zero (0) step, fully shut position, then retract to a known position.

### OCTANE ADJUST

- This function instructs the electronic control module to "read, store, and use" the current value of the octane adjustment potentiometer input signal. This adjustment is usually set at the factory to allow using high octane fuel. An adjustment would be performed if the customer desires to use low octane fuel. When the Tech 1 is not commanding this function, the octane adjustment input signal from the

potentiometer is only used to determine if the circuit is good or faulty. Refer to CHART C-15, "Octane Adjustment," for further information.

### CLEAR CODES

- This function will erase all stored diagnostic trouble codes from the electronic control module's memory, without the need to either disconnect the battery or remove power from the electronic control module.

### CRANK TEST

This is a special test that monitors and records the engine cranking speed (revolutions per minute), battery voltage while cranking, and could be useful in diagnosing a "hard start" engine that might be due to low engine cranking speed.

### TECH 1 "SCAN" TOOL LIMITATIONS

The Tech 1 "Scan" tool must receive the signal from the electronic control module in order to display any usable information. If the electronic control module sends no signals to the assembly line data link diagnostic connector, or the connection to the Tech 1 is defective, the Tech 1 "Scan" tool will only display, "NO DATA. RESELECT OR TURN "OFF" AND CHECK ASSEMBLY LINE DATA LINK CONNECTOR." The "DIAGNOSTIC CIRCUIT CHECK" instructs the mechanic what to do if this happens.

The Tech 1 "Scan" tool has a few limitations. If the Tech 1 "Scan" tool is displaying an electronic control module "output" function, it displays only the *command* given by the electronic control module. That does not mean that the desired action took place. This is similar to the dashboard gearshift indicator on a vehicle with an automatic transmission. Just because the gearshift pointer indicates the transmission is in "drive" gear does not mean that the transmission is actually in that gear. To be sure, you must check the linkage and adjustment at the transmission. When using the Tech 1 "Scan" tool to observe one of the electronic control module "output" functions, such as intake manifold heater, idle air control valve, or canister purge, the mechanic must not assume the *indicated* is the same as the *actual*. If the Tech 1 "Scan" tool is displaying manifold heater as being "ON," but the manifold heater relay is disconnected or defective, or if the heater element is burnt out, the electronic control module has no way of knowing it. The display may indicate the command is "ON," but the device may not be operating!

## 2-10 ENGINE MANAGEMENT SYSTEMS 1.7L THROTTLE BODY INJECTION

The Tech 1 "Scan" tool saves time in diagnosis and helps to prevent the replacement of good parts. *The key to using the "Scan" tool successfully for diagnosis is the technician's ability to understand the system being diagnosed, as well as an understanding of the Tech 1 "Scan" tool's limitations.*

The following information will describe all of the Tech 1 "Scan" tool mode F0 data list displays, and how they help in diagnosis.

With an understanding of the data the Tech 1 "Scan" tool displays, and knowledge of the circuits involved, the Tech 1 "Scan" tool is useful in getting information which is difficult or impossible to get with other methods.

The Tech 1 "Scan" tool does NOT make using diagnostic charts unnecessary, nor can it tell you exactly where a problem is in a circuit. Most diagnostic charts incorporate diagnosis procedures that require the use of a Tech 1 "Scan" tool.

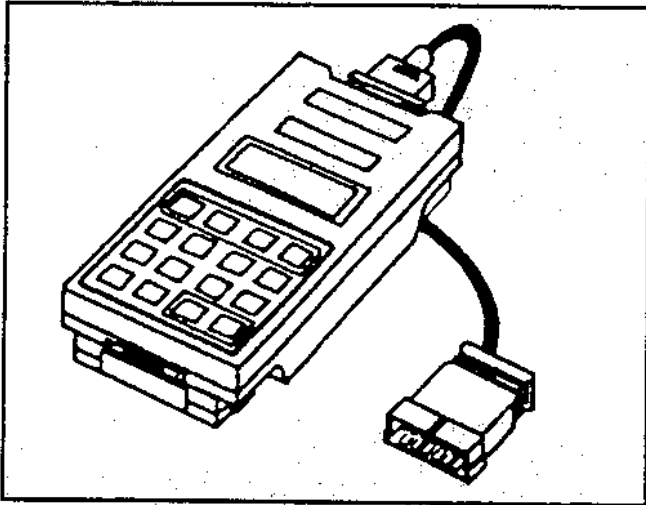

Figure 2.3-1 Tech 1 "Scan" Tool

### DIAGNOSTIC MODES

The electronic control module and the Tech 1 tool have various modes for communicating information between themselves. The following describes system operation in the different modes.

#### DIAGNOSTIC DISPLAY MODE

1. Ignition "ON," engine not running.
2. Tech 1 in the "F1: Field Service" mode, but with the *engine not running*. (This can also be done without the Tech 1 by using a jumper wire to connect the assembly line data link connector terminals "A" and "B" together.)

When in the diagnostic display mode, these actions take place:

- "Check Engine" light flashes codes.
- Certain solenoids and relays are energized.
- Idle air control valve moves to its fully extended position, closing the idle air passage in the throttle body injection unit.
- Diagnostic trouble codes cannot be stored.

#### FIELD SERVICE MODE

Similar to "Diagnostic Display" mode, except with the *engine running*.

1. Engine running.
2. Tech 1 in the "F1: Field Service" mode. (This can also be done without the Tech 1 by using a jumper wire to connect the assembly line data link connector terminals "A" and "B" together.)

When in the "Field Service" mode, these actions take place:

- Electronic spark timing will be fixed at 10° before top dead center when engine revolutions per minute are less than 2,000.
- Idle air control valve will be commanded to a fixed position.
- In the "Field Service" mode, the "Check Engine" light will flash in a different manner. Refer to "Field Service" mode explanation on Page 2-6 for information about how the "Check Engine" light will flash in this mode.

### TECH 1 "F0: DATA LIST" PARAMETERS

#### TECH 1 "F0: DATA LIST"

When the Tech 1 tool is connected and the F0 data list mode is selected, the data parameters are displayed in pairs.

The Tech 1 has preprogrammed data pairs. If custom data pairs are desired, any individual parameter can be paired with any other parameter. Refer to the Tech 1 owner's manual for further information about selecting customized data parameter pairs.

#### ENGINE SPEED

Displays the electronic control module's interpretation of actual engine revolutions per minute, as received from the crankshaft reference input signal.

Often useful to detect if extra reference pulses are suspected. A sudden high engine speed indication while at a steady throttle would indicate electrical interference in the crankshaft reference input signal circuit. This interference is usually caused by electronic control module wires too close to ignition secondary wires or an open crankshaft reference low Circuit 58 wire.

**DESIRED IDLE**

While the engine is idling the electronic control module is controlling idle speed. Desired idle is the closed throttle engine speed that is commanded by the electronic control module.

**COOLANT TEMPERATURE**

Displays the electronic control module's interpretation of coolant temperature in the engine. The coolant temperature sensor is mounted in the engine and is wired to the electronic control module. The electronic control module monitors the difference in voltage between two terminals, and then converts the voltage to a temperature shown in degrees Celsius. The reading should read close to the air temperature when the engine is cold, and rise as the coolant temperature rises. After engine is started the temperature should rise steadily to about 85°C-95°C then stabilize as the thermostat opens.

**INTAKE AIR TEMPERATURE**

Displays intake air temperature as interpreted by the electronic control module. The intake air temperature sensor is a thermistor and is mounted in the air cleaner.

**THROTTLE POSITION**

Displays the throttle position sensor signal input to the electronic control module. Values will be in voltage from which the electronic control module calculates the throttle opening.

The display is the electronic control module's interpretation of the throttle position sensor input voltage. With the throttle fully closed the voltage should be within 0.25-1.25 volts and go up to about 4.5 volts at wide open throttle.

**THROTTLE ANGLE**

Displays the electronic control module computed throttle angle as a function of the throttle position sensor input voltage (see above). 0% refers to a completely closed throttle while 100% is wide open.

**MANIFOLD ABSOLUTE PRESSURE**

Displays the electronic control module's interpretation of the intake manifold absolute pressure. Manifold absolute pressure sensor output voltage range is from zero to five volts, but the normal operating range is from about 0.30 to 4.90 volts. This value on the Tech 1 "Scan" tool cannot change until the engine is started, even though the actual manifold absolute pressure sensor output voltage can change. With the engine running, the voltage will be about 1-2 volts at idle. As engine load increases, this voltage also increases.

**BAROMETRIC PRESSURE**

This parameter represents calculated barometric air pressure, based on the signal from the absolute pressure sensor when the ignition is first switched "ON" before the engine starts. The electronic control module can update its baro pressure calculation when the engine is operating with the throttle nearly wide open at low engine speed. Because barometric air pressure depends on altitude, it may vary from 105 kPa (at or below sea level) to 60 kPa (4300 meters above sea level). On the Tech 1, the calculated barometric pressure is displayed.

**OXYGEN SENSOR VOLTAGE**

Displays oxygen sensor voltage in millivolts. When the sensor is cold this voltage will be close to 450 mV. As the sensor's electric heater begins to heat up the oxygen sensor, the voltage will fluctuate between 100-900 mV when the engine is running. If the engine isn't running but the ignition is "ON," the oxygen sensor voltage will slowly decrease to less than 200 mV.

**EXHAUST GASES (RICH/LEAN)**

This display will indicate if the electronic control module is interpreting a "rich" or "lean" exhaust signal from the oxygen sensor.

**OXYGEN SENSOR READY (YES/NO)**

This display will indicate whether or not the oxygen sensor is in the "ready" state. "Ready" can also be interpreted as "up to temperature."

**"OPEN/CLOSED LOOP" FUEL CONTROL**

Displays either "Open Loop" or "Closed Loop" depending on the state of the fuel control system. Time since start up, oxygen sensor ready status and coolant temperature all contribute to the change from "Open" to "Closed Loop."

## 2-12 ENGINE MANAGEMENT SYSTEMS 1.7L THROTTLE BODY INJECTION

### "CLOSED LOOP" FUEL ADJUSTMENT

This will display corrections made to the fuel injector pulse width based on the rich/lean indication from the oxygen sensor signal. As with memory fuel adjustment, the scale will be -99% to +99%.

### MEMORY FUEL ADJUSTMENT

Indicates what "state" the fuel correction is in. 0% is the middle with no fuel being reduced from or added to the injector pulse width calculations. If fuel is being added to the system the display will read between +1% and +99%. If fuel is being reduced the display will read between -1% and -99%.

### MEMORY FUEL ADJUSTMENT CELL

This display will indicate which memory fuel cell is currently being used.

### AIR FUEL RATIO

The amount of air compared to the amount of fuel in the air-fuel mixture commanded by the electronic control module. See "Stoichiometric Ratio" in glossary.

### POWER ENRICHMENT MODE ACTIVE? (YES/NO)

The display will indicate whether or not the fuel control system is in the power enrichment mode.

### DECEL FUEL CUT MODE IN EFFECT? (YES/NO)

Display indicates when decel fuel cut off mode is in effect.

### EVAPORATIVE EMISSION CANISTER PURGE CYCLE

Displays the pulse width modulation command (0-100%) of the canister purge solenoid.

### FUEL INJECTOR PULSE WIDTH

The injector pulse width is the length of time (in milliseconds) the electronic control module is commanding the fuel injector on. Injector "ON" time is how electronic fuel injection systems control fuel mixture (air/fuel ratio). A longer "ON" time yields more fuel delivered, and a richer mixture.

### SPARK ADVANCE

Displays the final total spark advance delivered to the spark plug.

### OCTANE ADJUST

This will display the voltage that the electronic control module is interpreting from the octane adjust potentiometer. This also displays the value of ignition timing retard as it relates to the voltage mentioned above.

### IDLE AIR CONTROL POSITION (0-255)

Displays the numbers that indicate what position the electronic control module has commanded the idle air control valve to be at. The electronic control module moves the idle air control in steps and these steps are what is displayed on the Tech 1 "Scan" tool. The number of "steps" or "counts" indicate how far open or shut the idle air passageway in the throttle body is. Larger numbers mean a larger opening in the idle air passageway, and a higher idle speed should occur. After the engine starts, the numbers should decrease as the engine warms to normal operating temperature. With the engine idling in "neutral" and the air conditioning not "ON," the numbers should be between 5 and 50 steps. Anything that makes the engine work harder at idle will cause this number to increase. Remember, this position shows the electronic control module *command*. There is no way to verify that the actual idle air control position is equal to the command.

### VEHICLE SPEED

Displays the electronic control module's interpretation of vehicle speed, as received from the vehicle speed sensor. If this position indicates no vehicle speed (zero), but the speedometer shows otherwise, then a Code 24 will eventually set. Also useful in checking speedometer accuracy.

### RADIATOR FAN

This will display "NOT USED" on NIVA vehicles.

### INTAKE MANIFOLD HEATER ("ON/OFF") RELAY

This will display the ("ON/OFF") status of the electronic control module control of this output.

### SYSTEM VOLTAGE

This will display the voltage of the battery, as interpreted by the electronic control module from the terminal which is connected to "Switched + 12V" from the ignition switch.



### AIR CONDITIONING REQUEST (YES/NO)

Displays when the operator has requested air conditioning. The display is the electronic control module's interpretation of the air conditioning request input signal to the electronic control module. The display will show "YES" if the electronic control module has 12 volts on this terminal, indicating that the electronic control module has been requested to turn "ON" the air conditioning compressor clutch. The display will show "NO" if the request signal is not received. The signal is a 12 volt signal from the air conditioning control switches.

Before the signal is received at the electronic control module, it must pass through the air conditioning high-side high-pressure switch, and the air conditioning cycling switch. If the switches are open the Tech 1 will display "NO" even though the air conditioning request switch is closed.

### AIR CONDITIONING ("ON/OFF") CLUTCH

The display will show the electronic control module's command to the air conditioning compressor control relay. It will show "ON" if the electronic control module has commanded the relay to operate the compressor, and "OFF" if the electronic control module has not commanded the relay to operate the compressor. Remember that the electronic control module command to the control relay is just that, a command. Do not assume that the compressor is running just because the command says "ON."

### FUEL PUMP CIRCUIT ("ON/OFF")

Indicates whether or not the fuel pump circuit is energized. This is a valuable display when diagnosing a suspected fuel pump circuit failure.

### CALIBRATION IDENTIFICATION

The programmable read only memory is located inside the electronic control module and has information on the vehicle's weight, engine transmission, axle ratio and other items specific to each vehicle. This identification is used to determine if the engine calibrator is the correct one for a particular vehicle.

### TIME FROM START

Time from start is available and is a measure of how long the engine has been running. If the engine stops, time from start will reset to 0:00:00.

## 2-14 ENGINE MANAGEMENT SYSTEMS 1.7L THROTTLE BODY INJECTION

### 2.4 UNDERHOOD LOCATION VIEW

### 1.7L THROTTLE BODY INJECTION

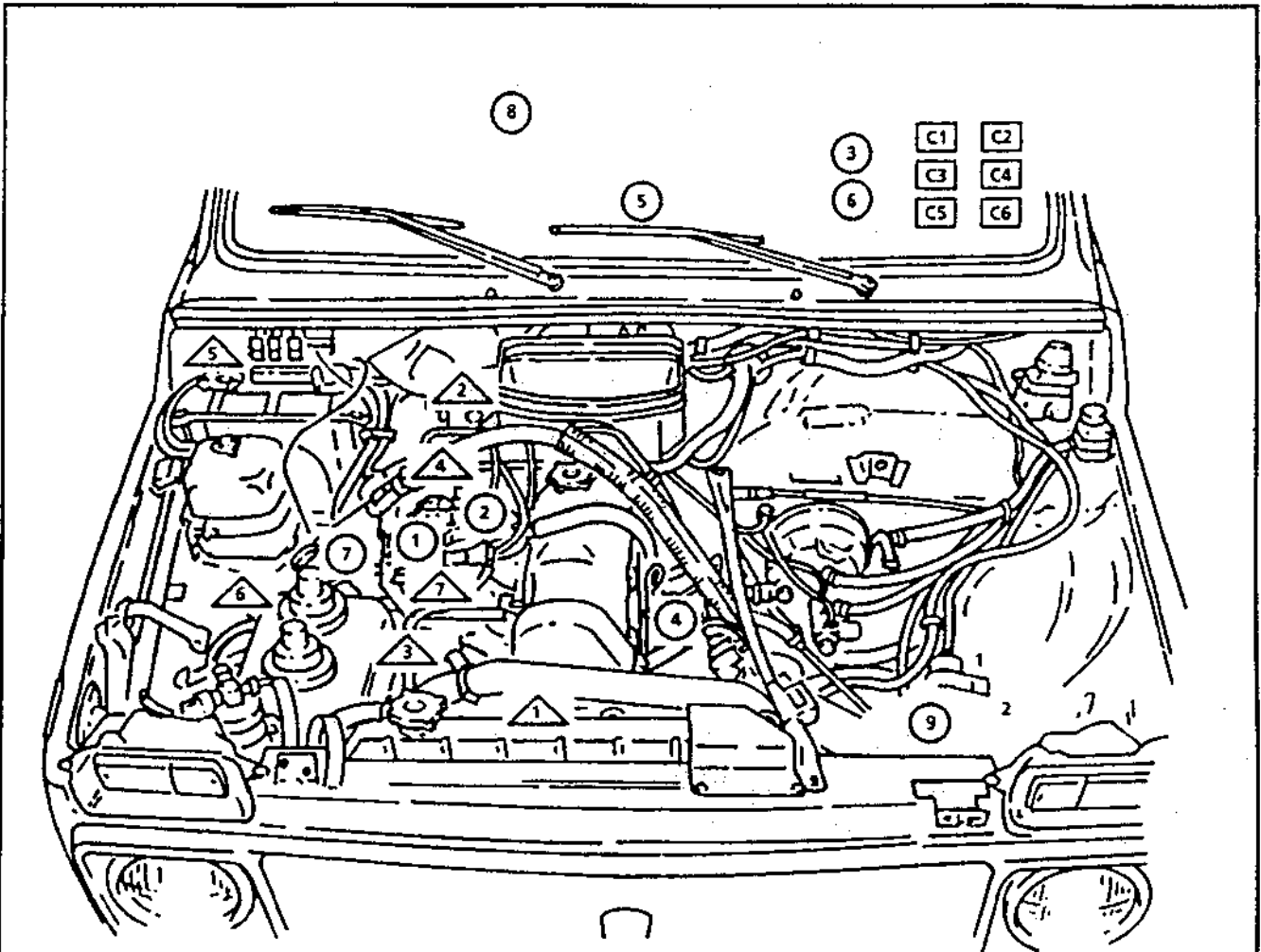

#### □ COMPUTER HARNESS

- C1 Electronic Control Module
- C2 Assembly Line Data Link\*
- C3 Fuse/Relay Block\*
- C4 Cross Car Harness Connector\*
- C5 Fuel Pump to Electronic Control Module Connector\*
- C6 Maxi-Fuse\*

#### MISCELLANEOUS

- 1 Fuel Filter
- 2 Fuel Pressure Tap\*

#### ○ CONTROLLED DEVICES

- 1 Fuel Injector
- 2 Idle Air Control Valve
- 3 Fuel Pump Relay\*
- 4 Ignition System Coils
- 5 Check Engine Light
- 6 Intake Manifold Heater Relay
- 7 Intake Manifold Heater (Under Throttle Body Injection Unit)
- 8 Fuel Pump (Under Access Panel in Storage Area)
- 9 Evaporative Emission Canister (mounted inside of the Engine Compartment near the radiator)

#### △ INFORMATION SENSORS

- 1 Crankshaft Position Sensor (Front of Engine, near end of Crankshaft)
- 2 Manifold Absolute Pressure Sensor
- 3 Coolant Temperature Sensor
- 4 Throttle Position Sensor
- 5 Octane Adjust Potentiometer
- 6 Oxygen Sensor (mounted in Exhaust Manifold below Throttle Body Injection Unit)
- 7 Intake Air Temperature Sensor (mounted in Air Cleaner - not shown)
- 8 Vehicle Speed Sensor (mounted under Vehicle to Transmission - not shown)

\* Actual location may vary.

7-1-92  
NS 14519

2.5 FUSEBLOCK VIEWS

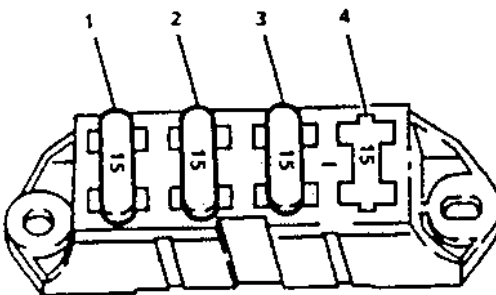

COLORS ARE SHOWN ON UNDERSIDE OF FUSE HOLDER

FUSE IDENTIFICATION CHART

| NUMBER | COLOR  |
|--------|--------|
| 1      | RED    |
| 2      | BLACK  |
| 3      | GREEN  |
| 4      | YELLOW |

7-1-92  
NS 13183

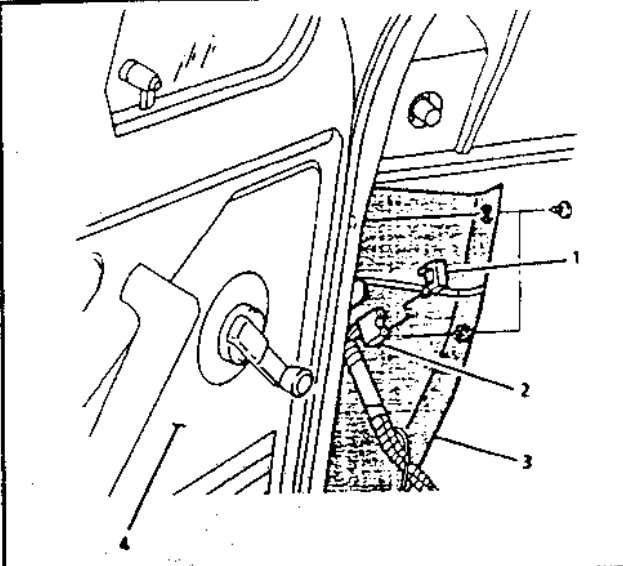

1 MAXI-FUSE  
2 MAXI-FUSE CONNECTOR  
3 KICK PANEL  
4 DRIVER'S DOOR

NS 13193

Maxi-Fuse Location View

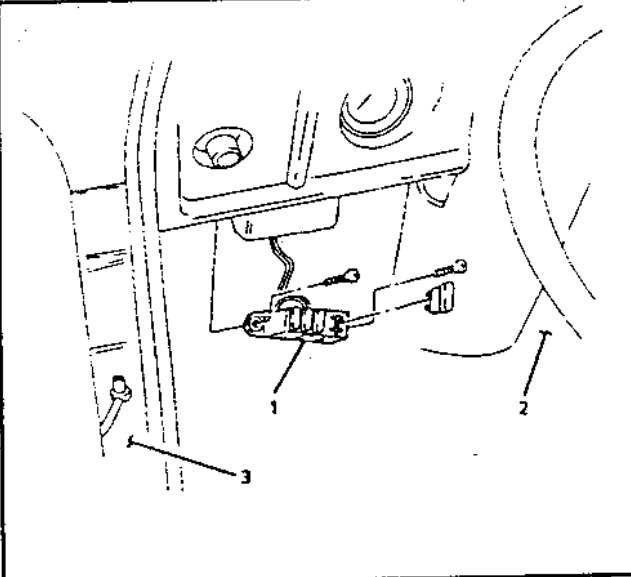

1 FUSEBLOCK  
2 STEERING WHEEL  
3 DRIVER SIDE DOOR

NS 13184

Fuse Block Location View

2.6 RELAY CALLOUT AND LOCATION VIEW

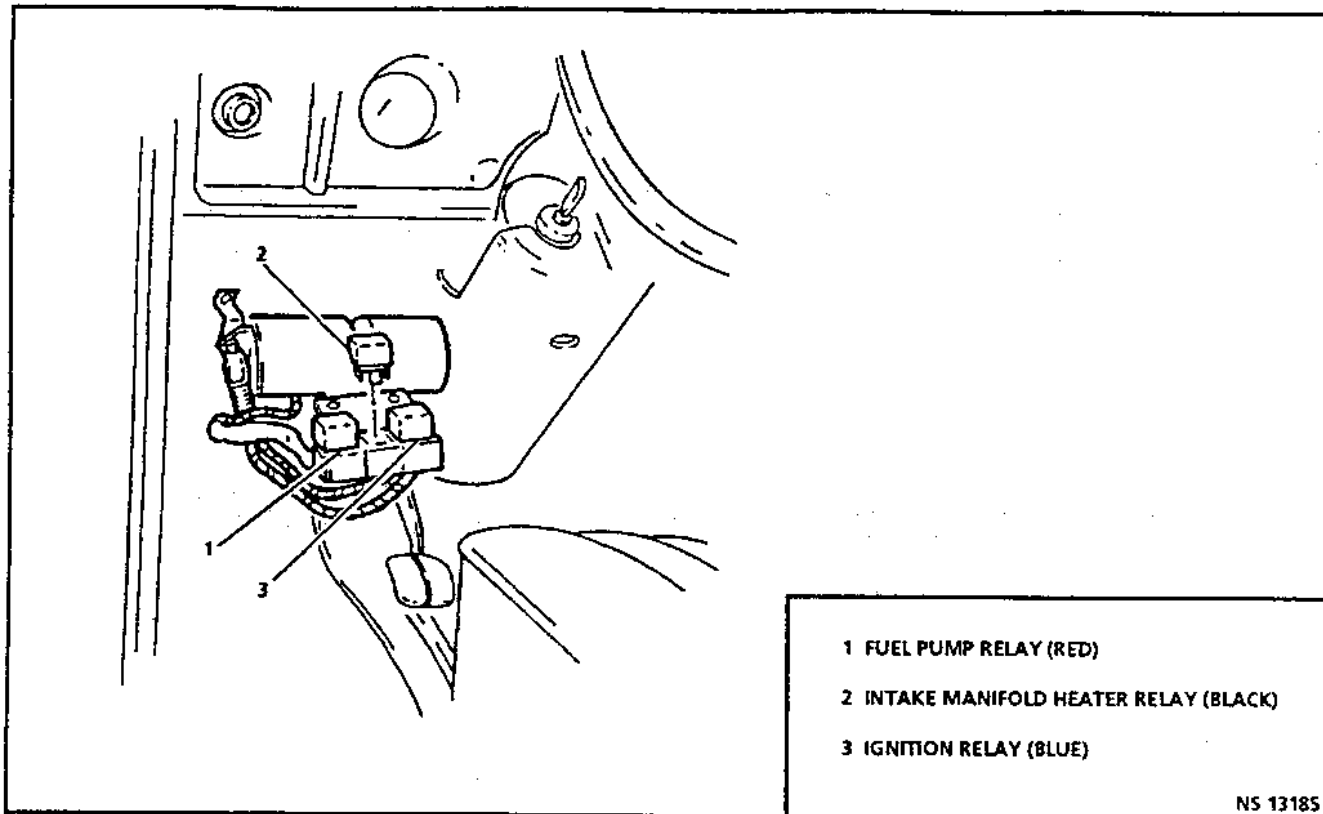

ENGINE MANAGEMENT SYSTEMS 1.7L THROTTLE BODY INJECTION 2-17

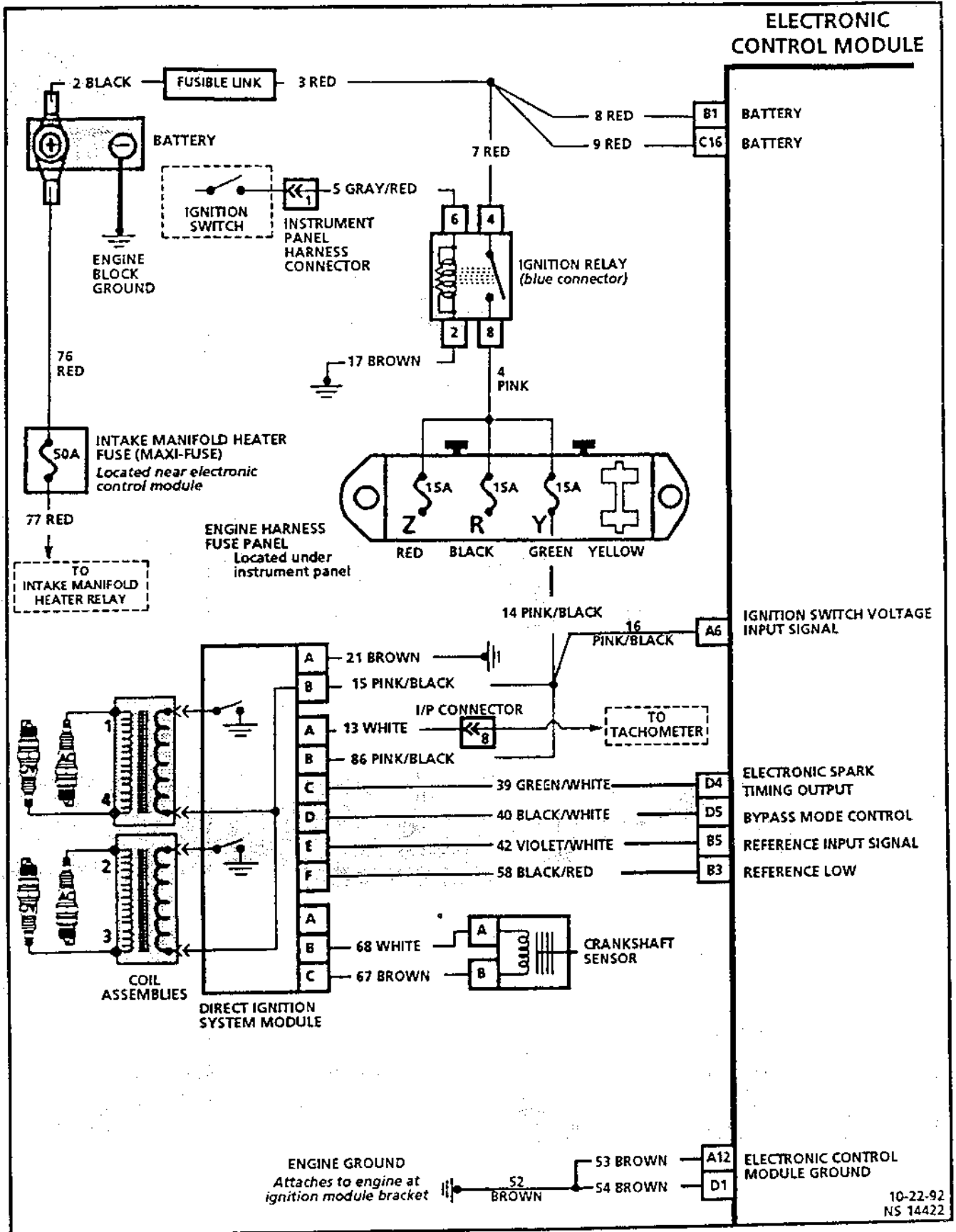

Engine Management System Wiring Diagram 1.7L Throttle Body Injection NIVA (1 of 5)

2-18 ENGINE MANAGEMENT SYSTEMS 1.7L THROTTLE BODY INJECTION

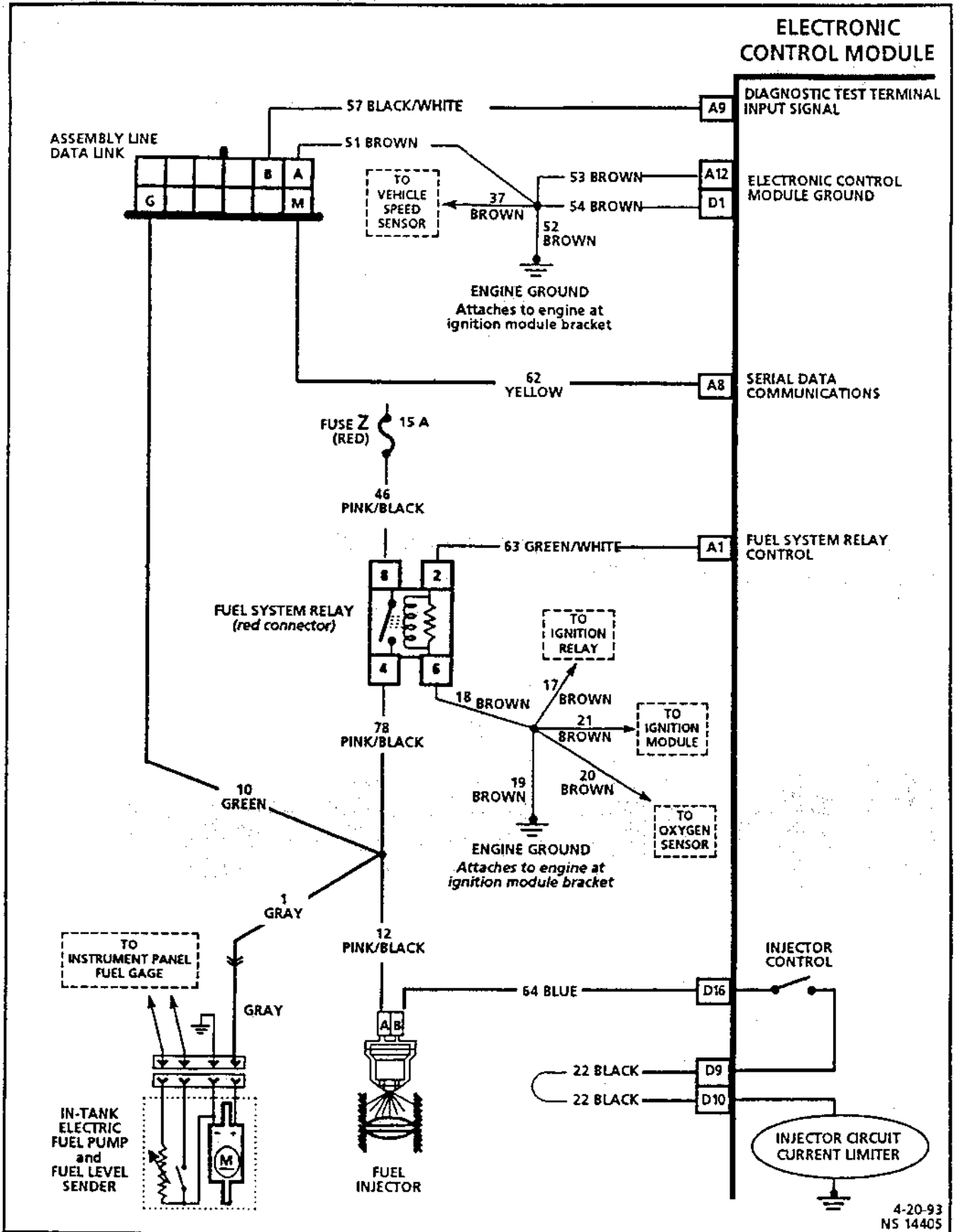

4-20-93  
NS 14405

Engine Management System Wiring Diagram 1.7L Throttle Body Injection NIVA (2 of 5)

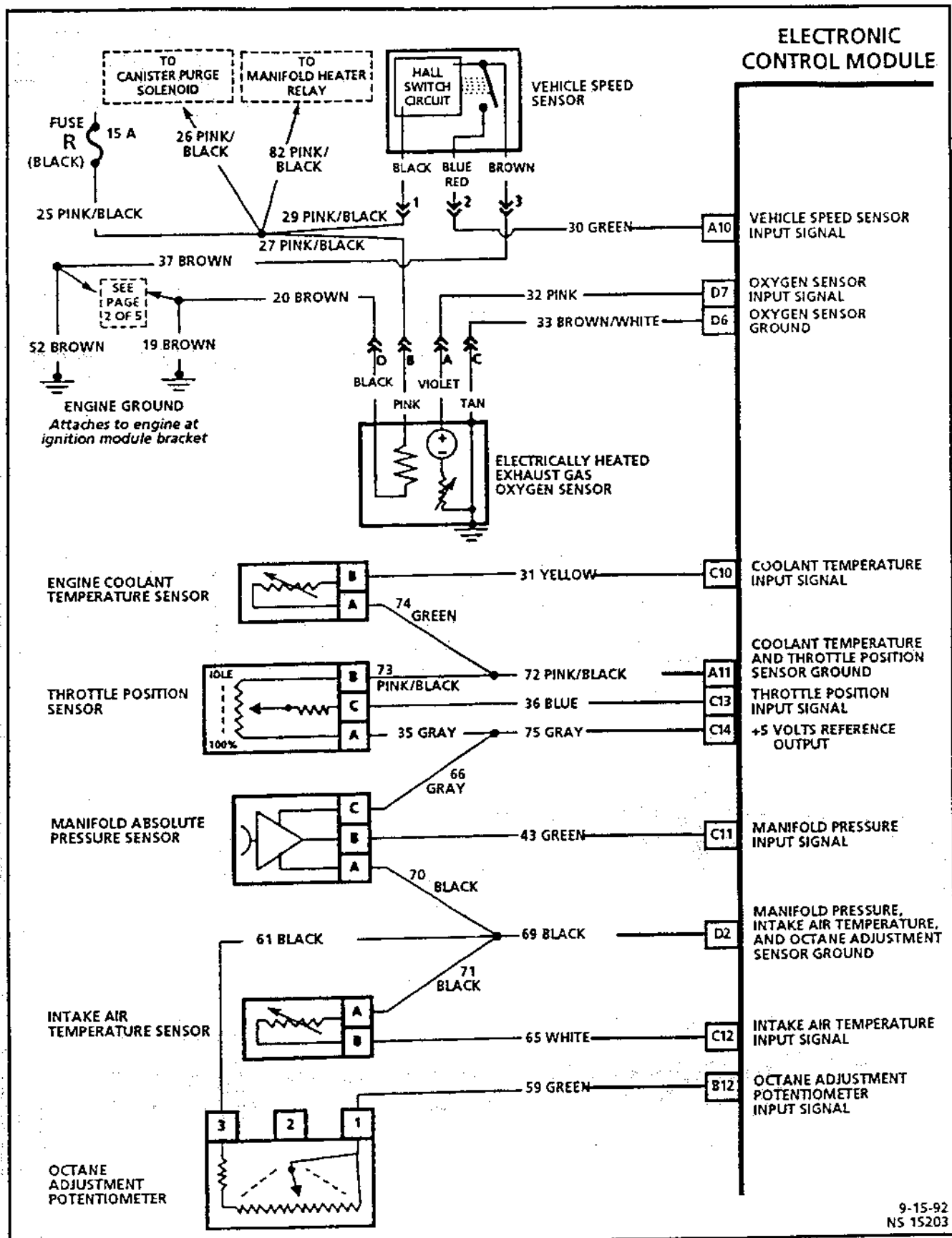

9-15-92  
NS 15203

Engine Management System Wiring Diagram 1.7L Throttle Body Injection NIVA (3 of 5)

2-20 ENGINE MANAGEMENT SYSTEMS 1.7L THROTTLE BODY INJECTION

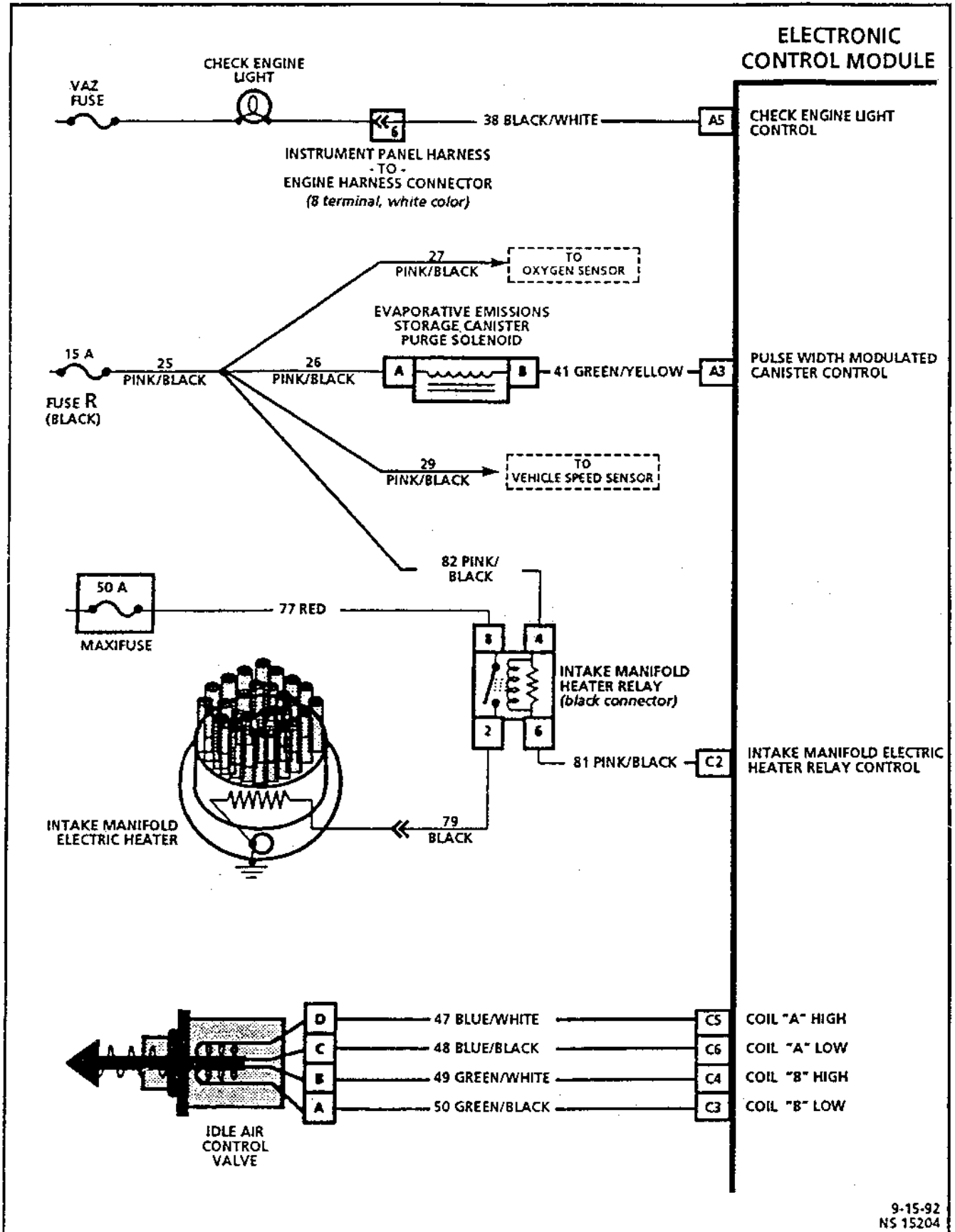

Engine Management System Wiring Diagram 1.7L Throttle Body Injection (4 of 5)



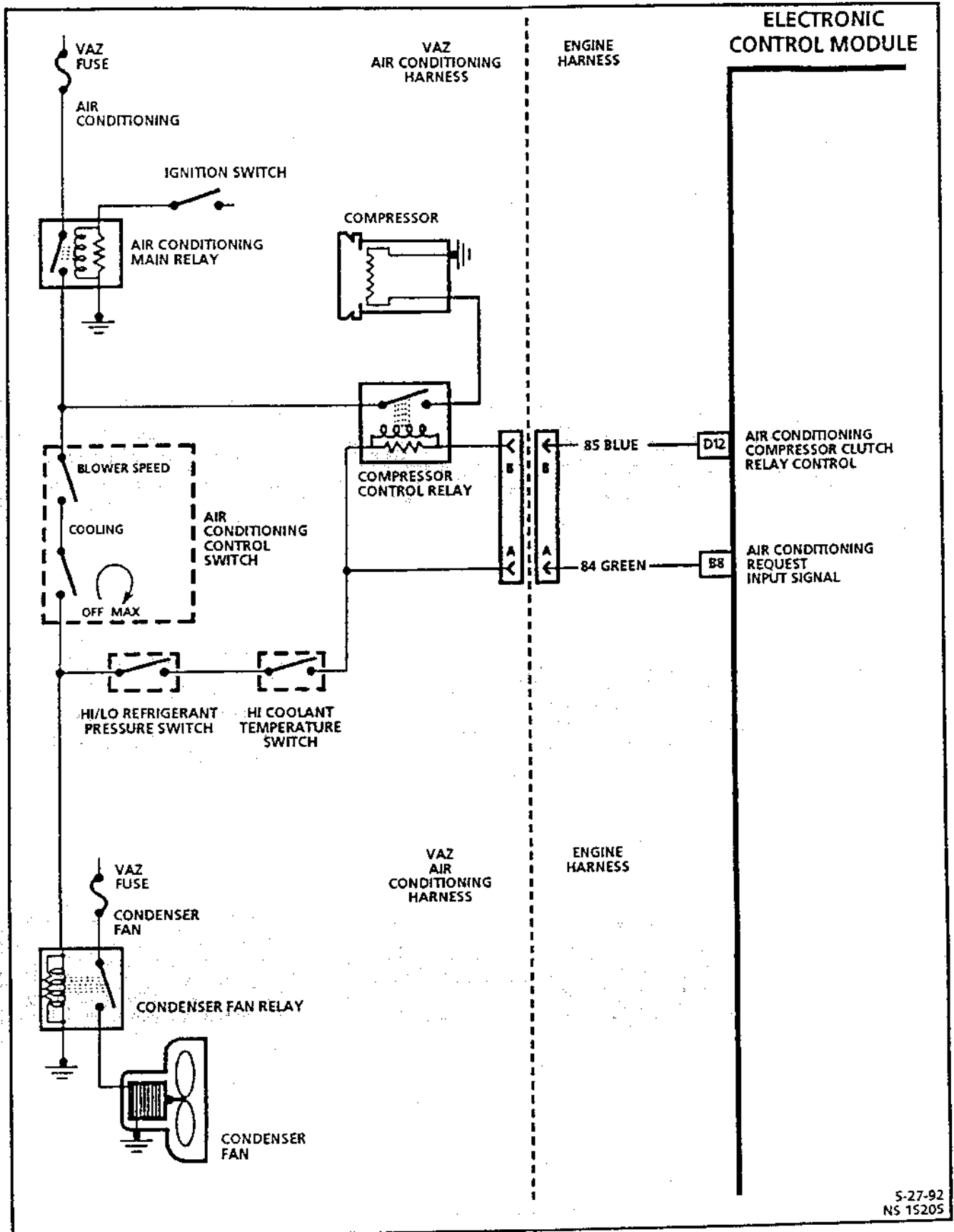

Engine Management System Wiring Diagram 1.7L Throttle Body Injection NIVA (5 of 5)

2.7 ELECTRONIC CONTROL MODULE CONNECTOR IDENTIFICATION CHARTS

TBI ELECTRONIC CONTROL MODULE CONNECTOR IDENTIFICATION

This electronic control module voltage chart is for use with a digital voltmeter to further aid in diagnosis. The voltages you get may vary due to low battery charge or other reasons, but they should be very close.

THE FOLLOWING CONDITIONS MUST BE MET BEFORE TESTING

- Engine at operating temperature
- Engine idling (For "Engine Run" column)
- Diagnostic "test" terminal not grounded
- Tech 1 "Scan" tool not installed
- Air conditioning "OFF"
- Digital voltmeter "-" (negative) lead connected to a good clean ground point.

DC VOLTAGE

| IGN "ON"    | ENG. RUN    | CIRCUIT  | PIN | WIRE COLOR   |
|-------------|-------------|--|-----|--------------|
| 0**         | B+          | FUEL SYSTEM RELAY CONTROL                                    | A1  | GREEN/WHITE  |
|             |             | NO CONNECTION  | A2  |              |
| B+          | VARIES ⑧    | PULSE WIDTH MODULATED CANISTER CONTROL                       | A3  | GREEN/YELLOW |
|             |             | NO CONNECTION  | A4  |              |
| 0*          | B+          | CHECK ENGINE LIGHT CONTROL                                   | A5  | BLACK/WHITE  |
| B+          | B+          | IGNITION SWITCH VOLTAGE INPUT SIGNAL                         | A6  | PINK/BLACK   |
|             |             | NO CONNECTION  | A7  |              |
| 2-5 VARYING | 2-5 VARYING | SERIAL DATA COMMUNICATIONS                                   | A8  | ORANGE       |
| 5           | 5           | DIAGNOSTIC "TEST" TERMINAL INPUT SIGNAL                      | A9  | BLACK/WHITE  |
| VARIES      | VARIES      | VEHICLE SPEED INPUT SIGNAL                                   | A10 | GREEN        |
| 0**         | 0**         | COOLANT TEMPERATURE SENSOR & THROTTLE POSITION SENSOR GROUND | A11 | PINK/BLACK   |
| 0**         | 0**         | ELECTRONIC CONTROL MODULE GROUND                             | A12 | BROWN        |

24-PIN A-B CONNECTOR



BACK VIEW OF CONNECTOR

- 1 Battery voltage for first two seconds, after ignition is turned "ON" without cranking the engine.
  - 2 When vehicle is stopped, voltage will be either less than 1 volt or more than 10 volts; depending upon position of drive wheels. When vehicle is moving, voltage will vary depending upon vehicle speed.
  - 3 Varies with temperature.
  - 4 Varies. With ignition "ON," reads barometric pressure. With engine running, reads engine load.
  - 5 Voltage will vary with engine revolutions per minute.
  - 6 Depending on octane adjustment potentiometer trim.
  - 7 Battery voltage (B +) with engine warm. Less than 0.5 volts on cold engine.
  - 8 Varies between battery voltage down to less than 1 volt, depending on 0%-100% duty cycle of pulse width modulated control signal.
- \* Less than 0.50 volt.  
 \*\* Less than 0,10 volt.  
 B + Should equal battery voltage

DC VOLTAGE

| IGN "ON"   | ENG. RUN | CIRCUIT                               | PIN | WIRE COLOR   |
|------------|----------|---------------------------------------|-----|--------------|
| B+         | B+       | BATTERY + (POWER SUPPLY)              | B1  | RED          |
|            |          | NO CONNECTION                         | B2  |              |
| 0**        | 0**      | CRANKSHAFT REFERENCE LOW              | B3  | BLACK/RED    |
|            |          | NO CONNECTION                         | B4  |              |
| 0*         | ⑤        | CRANKSHAFT REFERENCE INPUT SIGNAL     | B5  | PURPLE/WHITE |
|            |          | NO CONNECTION                         | B6  |              |
|            |          | NO CONNECTION                         | B7  |              |
| 0*         | 0*       | AIR CONDITIONING REQUEST INPUT SIGNAL | B8  | GREEN        |
| 0*         | B+       | NO CONNECTION                         | B9  |              |
|            |          | NO CONNECTION                         | B10 |              |
|            |          | NO CONNECTION                         | B11 |              |
| ⑥ 1-5 VOLT | 1-5 VOLT | OCTANE ADJUSTMENT INPUT SIGNAL        | B12 | GREEN        |

ENGINE 1.7L Throttle Body Injection/NIVA

10-1-92  
NS 14327

Figure 2.7-1 ECM Connector Terminal End View 1.7L Throttle Body Injection NIVA (1 of 2)

DC VOLTAGE

| IGN "ON"    | ENG. RUN  | CIRCUIT                                       | PIN | WIRE COLOR  |
|-------------|-----------|---|-----|-------------|
|             |           | NO CONNECTION                                 | C1  |             |
| B+          | B+        | INTAKE MANIFOLD ELECTRIC HEATER RELAY CONTROL | C2  | PINK/BLACK  |
| NOT         | USEABLE   | IDLE AIR CONTROL COIL "B" LOW                 | C3  | GREEN/BLACK |
| NOT         | USEABLE   | IDLE AIR CONTROL COIL "B" HIGH                | C4  | GREEN/WHITE |
| NOT         | USEABLE   | IDLE AIR CONTROL COIL "A" LOW                 | C5  | BLUE/BLACK  |
| NOT         | USEABLE   | IDLE AIR CONTROL COIL "A" HIGH                | C6  | BLUE/WHITE  |
|             |           | NO CONNECTION                                 | C7  |             |
|             |           | NO CONNECTION                                 | C8  |             |
|             |           | NO CONNECTION                                 | C9  |             |
| ③ 1-2       | 1-2       | COOLANT TEMPERATURE INPUT SIGNAL              | C10 | YELLOW      |
| ④ 3.5 - 5.0 | 0.9 - 1.5 | MANIFOLD ABSOLUTE PRESSURE INPUT SIGNAL       | C11 | GREEN       |
| ③           |           | INTAKE AIR TEMPERATURE INPUT SIGNAL           | C12 | WHITE       |
| 3 - 7       | .3 - .7   | THROTTLE POSITION INPUT SIGNAL                | C13 | BLUE        |
| 5           | 5         | +5 VOLT REFERENCE OUTPUT                      | C14 | GRAY        |
|             |           | NO CONNECTION                                 | C15 |             |
| B+          | B+        | BATTERY +                                     | C16 | RED         |

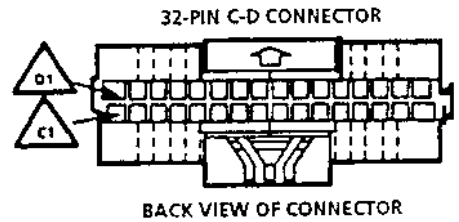

- 1 Battery voltage for first two seconds, after ignition is turned "ON" without cranking the engine.
  - 2 When vehicle is stopped, voltage will be either less than 1 volt or more than 10 volts; depending upon position of drive wheels. When vehicle is moving, voltage will vary depending upon vehicle speed.
  - 3 Varies with temperature.
  - 4 Varies. With ignition "ON," reads barometric pressure. With engine running, reads engine load.
  - 5 Voltage will vary with engine revolutions per minute.
  - 6 Depending on octane adjustment potentiometer trim.
  - 7 Battery voltage (B + ) with engine warm. Less than 0.5 volts on cold engine.
  - 8 Varies between battery voltage down to less than 1 volt, depending on 0%-100% duty cycle of pulse width modulated control signal.
- \* Less than 0.50 volt.  
 \*\* Less than 0.10 volt.  
 B + Should equal battery voltage

DC VOLTAGE

| IGN "ON" | ENG. RUN                     | CIRCUIT  | PIN | WIRE COLOR  |
|----------|------------------------------|--|-----|-------------|
| 0**      | 0**                          | ELECTRONIC CONTROL MODULE GROUND   | D1  | BROWN       |
| 0**      | 0**                          | OCTANE ADJUST POTENTIOMETER, MANIFOLD ABSOLUTE PRESSURE SENSOR, AND INTAKE AIR TEMPERATURE SENSOR GROUND | D2  | BLACK       |
|          |                              | NO CONNECTION  | D3  |             |
| 0*       | 1.2                          | ELECTRONIC SPARK TIMING OUTPUT   | D4  | GREEN/WHITE |
| 0        | 4.6                          | IGNITION MODULE BYPASS MODE CONTROL  | D5  | BLACK/WHITE |
| 0**      | 0*                           | OXYGEN SENSOR GROUND   | D6  | BROWN       |
| 0.1-0.2  | VARIES                       | OXYGEN SENSOR INPUT SIGNAL   | D7  | PINK        |
|          |                              | NO CONNECTION  | D8  |             |
| 0**      | 0**                          | INJECTOR CIRCUIT CURRENT LIMITER JUMPER  | D9  | BLACK       |
| 0**      | 0**                          | INJECTOR CIRCUIT CURRENT LIMITER JUMPER  | D10 | BLACK       |
|          |                              | NO CONNECTION  | D11 |             |
| 0*       | B+ A/C "OFF",<br>0* A/C "ON" | AIR CONDITIONING COMPRESSOR CLUTCH RELAY CONTROL   | D12 | BLUE        |
|          |                              | NO CONNECTION  | D13 |             |
|          |                              | NO CONNECTION  | D14 |             |
|          |                              | NO CONNECTION  | D15 |             |
| B+       | B+                           | INJECTOR CONTROL   | D16 | BLUE        |

ENGINE 1.7L Throttle Body Injection/NIVA

10-1-92  
NS 14328

Figure 2.7-2 ECM Connector Terminal End View 1.7L Throttle Body Injection NIVA (2 of 2)

## 2.8 ELECTRONIC CONTROL MODULE TERMINALS DEFINED

## ELECTRONIC CONTROL MODULE CONNECTOR VOLTAGES WITH EXPLANATIONS

- A1 FUEL SYSTEM RELAY CONTROL** - Turning the ignition "ON" signals the electronic control module to energize (+12V) the fuel system relay. If no crankshaft reference input pulses are received, the electronic control module turns "OFF" the relay. When the electronic control module receives crankshaft reference input (terminal "B5") the electronic control module turns the fuel pump relay back "ON."
- A2 NO CONNECTION**
- A3 PULSE WIDTH MODULATED CANISTER CONTROL** - The electronic control module supplies the ground circuit to energize the evaporative emission storage canister control solenoid. With the engine stopped this terminals should equal the battery voltage. With the engine running, the voltage will be between battery voltage and zero. The voltage level will depend on the 0%-100% pulse width modulated control signal sent to the canister solenoid.
- A4 NO CONNECTION**
- A5 CHECK ENGINE LIGHT CONTROL** - The electronic control module supplies the ground to turn the "Check Engine" light "ON". With the ignition "ON" and the engine not running, the "Check Engine" light should be "ON," terminal "A5" voltage is close to zero. With the "Check Engine" light not "ON," the voltage at terminal "A5" is battery voltage.
- A6 IGNITION SWITCH VOLTAGE INPUT SIGNAL** - This is the "turn on" signal to the electronic control module from the ignition switch circuit. It is *not* the "power supply" to the electronic control module; it signals the electronic control module the ignition is "ON." The voltage equals battery voltage when the ignition switch is in either the 'run' or 'crank' position.
- A7 NO CONNECTION**
- A8 SERIAL DATA COMMUNICATIONS** - From terminal "A8" the electronic control module sends out information (data) about its inputs and outputs to the assembly line data link terminal "M". This data is sent as a string of rapidly changing voltage signals pulsed from high (+5 volts) to low (0 volts). The Tech 1 "Scan" tool, when connected, interprets the varying square-wave signal and displays the data. The data is sent in a serial fashion; that is, one piece after the other until all the information has been sent—then the process begins again. Voltage, when measured with a digital voltmeter, will rapidly change between 1 and 5 volts.
- A9 DIAGNOSTIC "TEST" TERMINAL INPUT SIGNAL** - This terminal is connected to the assembly line data link diagnostic "test" terminal "B". When the diagnostic "test" terminal is not grounded, this terminal will have 5 volts on it. When the assembly line data link diagnostic "test" terminal is grounded, the resulting zero voltage at the electronic control module causes it to operate in the Diagnostic Mode or the Field Service Mode, depending if the engine is stopped or running.
- A10 VEHICLE SPEED INPUT SIGNAL** - The electronic control module sends a +12V *signal* voltage to the vehicle speed sensor. The vehicle speed sensor *pulses* the signal to ground, these pulses vary in frequency with the speed of the car.
- A11 COOLANT TEMPERATURE AND THROTTLE POSITION SENSOR GROUND** - This terminal should be nearly zero volts. It is connected through the electronic control module circuitry to engine ground.
- A12 ELECTRONIC CONTROL MODULE GROUND** - This terminal has nearly zero volts. It is connected directly to the engine at the direct ignition system mounting bracket.

- B1 BATTERY + (Power Supply)** - This terminal "B1" supplies the electronic control module with full-time +12 volts. It is hot even when the ignition is turned "OFF." It receives voltage through the fusible link. This electronic control module terminal could be called the power supply and "MEMORY" terminal, along with terminal "C16".
- B2 NO CONNECTION**
- B3 CRANKSHAFT REFERENCE LOW** - This terminal is always nearly zero volts. It is connected through the ignition module to engine ground.
- B4 NO CONNECTION**
- B5 CRANKSHAFT REFERENCE INPUT SIGNAL** - This terminal could be called the "tach" input. It provides the electronic control module with revolutions per minute and crankshaft position information. With ignition "ON," but the engine not running, the voltage is less than 1 volt. As the crankshaft turns, the voltage increases with revolutions per minute.
- B6 NO CONNECTION**
- B7 NO CONNECTION**
- B8 AIR CONDITIONING REQUEST INPUT SIGNAL** - When the instrument panel air conditioning switch is "OFF," the voltage at this terminal is near zero. When the switch is "ON," a +12 volt signal is sent to the electronic control module.
- B9 NO CONNECTION**
- B10 NO CONNECTION**
- B11 NO CONNECTION**
- B12 OCTANE ADJUSTMENT INPUT SIGNAL** - The octane adjust potentiometer output voltage, which depends on the potentiometer voltage adjustment, is variable from 1-5 volts. By monitoring this output voltage, the electronic control module makes small changes in the total spark advance to allow for low octane fuel.
- C1 NO CONNECTION**
- C2 INTAKE MANIFOLD ELECTRIC HEATER RELAY CONTROL** - This terminal has battery voltage until the electronic control module energizes the relay by supplying the ground, then the voltage is close to zero. The input that causes the electronic control module to energize the relay is C10 - COOLANT TEMPERATURE SENSOR. The electronic control module also energizes the relay in the Diagnostic Mode - ignition "ON," the engine not running with the assembly line data link diagnostic "test" terminal "B" jumpered to "A".
- C3, C4, C5, C6 IDLE AIR CONTROL COILS** - These terminals are connected to the idle air control valve, located on the throttle body. It is difficult to predict what the voltage will be, and the measurement is not usable for service procedures.
- C7 NO CONNECTION**
- C8 NO CONNECTION**
- C9 NO CONNECTION**
- C10 COOLANT TEMPERATURE INPUT SIGNAL** - The electronic control module sends a 5 volt signal to the coolant temperature sensor—a temperature-variable-resistor, called a thermistor. The sensor, also connected to ground, varies the voltage based on engine coolant temperature. As the engine coolant temperature increases, the voltage on terminal "C10" decreases. At 0°C engine coolant temperature, the voltage is above 4 volts. At normal operating temperature (85°C to 100°C) the voltage is less than 2 volts.

## 2-26 ENGINE MANAGEMENT SYSTEMS 1.7L THROTTLE BODY INJECTION

- C11 MANIFOLD ABSOLUTE PRESSURE INPUT SIGNAL** - The voltage on terminal "C11" varies with intake manifold pressure. The sensor monitors intake manifold pressure by a small hose connected to the sensor from the throttle body. With the ignition "ON" and the engine not running (high manifold pressure) the voltage is above 4 volts. This is the barometric pressure measurement, and this voltage changes with both barometric pressure and altitude. When the engine is running at idle, the manifold pressure is quite low due to engine vacuum; therefore, the voltage is also low -1 to 2 volts. The voltage is variable, mostly from engine intake manifold pressure changes, but it can change with barometric pressure or altitude changes. This is typically called the "engine load" input.
- C12 INTAKE AIR TEMPERATURE INPUT SIGNAL** - The electronic control module sends a 5 volt signal to the air temperature sensor—a temperature-variable-resistor, called a thermistor. The sensor, also connected to ground, varies the voltage based on intake air temperature. As the intake air temperature increases, the voltage on terminal "C12" decreases. At 0°C intake air temperature, the voltage is above 4 volts. At normal operating temperature (85°C to 100°C) the voltage is less than 2 volts.
- C13 THROTTLE POSITION INPUT SIGNAL** - The throttle position sensor input voltage, which follows actual throttle changes, is variable from 0 to 5 volts. Typically the voltage is less than 1 volt at idle, and 4 to 5 volts at wide-open throttle.
- C14 + 5 VOLTS REFERENCE** - This voltage is always nearly 5 volts with the ignition "ON." It is a regulated voltage output from the electronic control module, and supplies 5 volts to the manifold absolute pressure and throttle position sensors.
- C15 NO CONNECTION**
- C16 BATTERY + (POWER SUPPLY)** - See terminal "B1".
- D1 ELECTRONIC CONTROL MODULE GROUND** - This terminal has nearly zero volts, it is connected directly to the engine at the direct ignition system mounting bracket.
- D2 OCTANE ADJUST, MANIFOLD ABSOLUTE PRESSURE, AND INTAKE AIR TEMPERATURE SENSOR GROUND** - This terminal is nearly zero volts, it is connected through the electronic control module to engine ground.
- D4 ELECTRONIC SPARK TIMING OUTPUT** - This terminal has very low voltage with the ignition "ON," but the engine not running. With the engine running at idle, the voltage is slightly more than 1 volt. As the engine revolutions per minute goes up, this voltage increases.
- D5 IGNITION MODULE BYPASS MODE CONTROL** - With ignition "ON" and the engine not running this terminal has very low voltage. When the electronic control module measures more than 500 revolutions per minute (engine "RUN" threshold) on B5 - CRANKSHAFT REFERENCE INPUT SIGNAL, the electronic control module turns on 5 volts to D5 - IGNITION MODULE BYPASS MODE CONTROL CIRCUIT.
- D6 OXYGEN SENSOR GROUND CIRCUIT** - This terminal should have zero volts. It is connected directly to the engine block at the ignition module bracket. This terminal grounds the electronic control module circuitry for the oxygen sensor voltage monitor inside the electronic control module.

- D7 OXYGEN SENSOR INPUT SIGNAL-** With ignition "ON" and engine not running, the voltage should drop from a starting point of approximately 0.450 volt to less than 0.200 volts. The oxygen sensor is electrically heated. When the engine is not running and the sensor is hot an abundance of oxygen in the exhaust manifold will be sensed and the sensor's output voltage would be less than 0.200 volts. If the sensor's electric heater is malfunctioning, the only voltage seen here with the engine stopped would be the "reference" voltage coming from the electronic control module. This reference voltage is a steady 400-500 mV (0.400-0.500 volt). With the engine running and after the oxygen sensor is hot, the voltage should be rapidly changing, somewhere between 10-1000 millivolts (.010-1.00 volts).
- D8 NO CONNECTION**
- D9, D10 INJECTOR CIRCUIT, CURRENT LIMITER JUMPER -** The electronic control module's injector control circuit uses this jumper to complete its path to ground through an internal current limiter. If this jumper circuit is open or missing, the vehicle will not start. If the circuit is shorted to ground the vehicle may run, but with reduced performance and poor driveability and would eventually cause the fuel injector to not operate.
- D11 NO CONNECTION**
- D12 AIR CONDITIONING COMPRESSOR CLUTCH RELAY CONTROL -** The electronic control module supplies the ground path on this terminal to energize the air conditioning compressor clutch control relay. The voltage is less than 1 volt when the electronic control module energizes the relay, but the voltage is also less than 1 volt if the electronic control module does not receive the "Air Conditioning Request" input voltage at terminal "B8".
- D13 NO CONNECTION**
- D14 NO CONNECTION**
- D15 NO CONNECTION**
- D16 FUEL INJECTOR CONTROL -** The voltage at this terminal comes through the injector which is connected to +12 volts. With the ignition "ON," and the engine not running, the voltage is equal to battery voltage. With the engine at idle, the charging system increases this battery voltage slightly. With higher engine revolutions per minute or more engine load, the increased injector pulse frequency and injector pulse width causes the voltage to be slightly less than at idle.

**BLANK**



## SECTION 2.9A

## DIAGNOSTIC CHARTS

## CONTENTS

|  |      |
|--|------|
| Diagnostic Charts Defined .....  | 2-30 |
| Tech 1 "Scan" Tool Typical Data Value .....  | 2-32 |
| Electronic Control Module Diagnostic Codes .....   | 2-35 |
| Chart A - Diagnostic Circuit Check .....   | 2-36 |
| Chart A-1- No "Check Engine" Light .....   | 2-38 |
| Chart A-2 - No Assembly Line Data Link Serial Data or Will Not Flash Code 12<br>("Check Engine" Light "ON" Steady) ..... | 2-40 |
| Chart A-3 - Engine Cranks But Will Not Run .....   | 2-42 |
| Chart A-4 - Ignition Relay and Power Circuits Check .....  | 2-48 |
| Chart A-5 - Fuel System Electrical Circuit Check .....   | 2-52 |
| Chart A-7 - Fuel System Diagnosis .....  | 2-54 |
| Code 13 - No Oxygen Sensor Signal .....  | 2-58 |
| Code 14 - Coolant Temperature (Signal Voltage Too Low) .....   | 2-60 |
| Code 15 - Coolant Temperature (Signal Voltage Too High) .....  | 2-62 |
| Code 21 - Throttle Position (Signal Voltage Too High) .....  | 2-64 |
| Code 22 - Throttle Position (Signal Voltage Too Low) .....   | 2-66 |
| Code 23 - Intake Air Temperature (Signal Voltage Too High) .....   | 2-68 |
| Code 24 - No Vehicle Speed Signal .....  | 2-70 |
| Code 25 - Intake Air Temperature (Signal Voltage Too Low) .....  | 2-72 |
| Code 33 - Manifold Absolute Pressure (Signal Voltage Too High) .....   | 2-74 |
| Code 34 - Manifold Absolute Pressure (Signal Voltage Too Low) .....  | 2-76 |
| Code 35 - Idle Speed Error .....   | 2-78 |
| Code 42 - Electronic Spark Timing Control Circuit Problem .....  | 2-80 |
| Code 44 - Lean Exhaust Indication .....  | 2-82 |
| Code 45 - Rich Exhaust Indication .....  | 2-84 |
| Code 51- Calibrator Error .....  | 2-86 |
| Code 53 - System Voltage Too High .....  | 2-88 |
| Code 54 - Octane Adjustment (Signal Voltage Too High or Too Low) .....   | 2-90 |
| Code 55 - Electronic Control Module Error .....  | 2-94 |

## 2.9 DIAGNOSTIC CHARTS DEFINED

### INTRODUCTION

The diagnostic charts are designed to provide fast and efficient fault location for the fuel system, electronic spark timing system and all other engine functions associated with the electronic control module. Each diagnostic chart uses 2 pages; a "trouble tree chart" on the right side page, and a "facing page" on the left side page. The left side "facing page" contains pertinent information, including malfunction code setting parameters and circuit diagrams. The trouble tree boxes with circled numbers are explained by the corresponding numbered paragraph on the left side facing page.

It is essential that the charts be used correctly. *When diagnosing any problem, ALWAYS BEGIN WITH THE DIAGNOSTIC CIRCUIT CHECK!* The Diagnostic Circuit Check will lead you into the other charts. **DO NOT GO DIRECTLY TO A SPECIFIC CHART** or false diagnosis and replacement of "good" parts could result.

After a fault is corrected and all codes have been cleared, it is advisable to repeat the Diagnostic Circuit Check to ensure that proper repairs have been made.

When the electronic control module is operating in the DIAGNOSTIC MODE, the "Check Engine" light will flash stored malfunction codes.

Each code displayed consists of a number of flashes representing the first digit followed by a short pause, then a number of flashes representing the second digit, followed by a longer pause indicating the end of the code.

Each stored code is displayed three times before proceeding to the next code. After all codes stored in memory have been displayed, the entire flashing sequence is repeated.

**Assembly Line Data Link Connector is located above the Electronic Control Module, which is mounted behind the left front kick panel.**

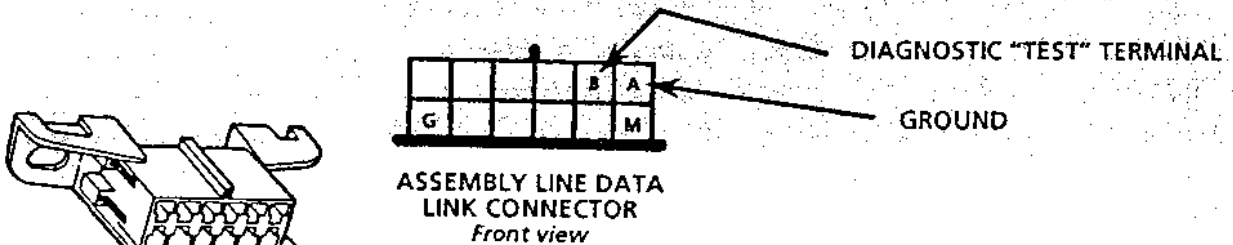

#### DIAGNOSTIC DISPLAY MODE:

- IGNITION ON
- ENGINE NOT RUNNING
- ASSEMBLY LINE DATA LINK 'DIAGNOSTIC TEST TERMINAL' GROUNDED

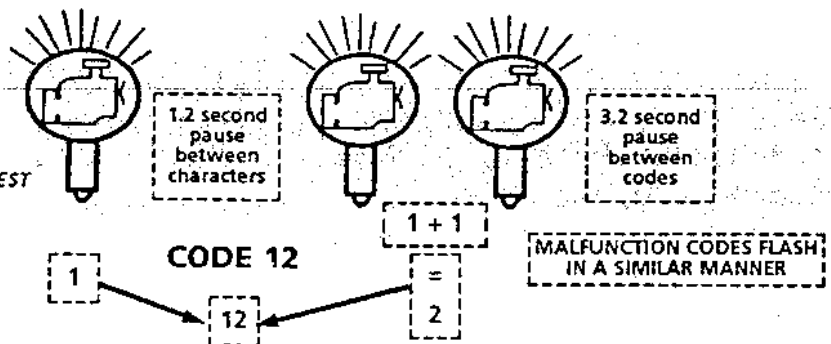

"CHECK ENGINE" LIGHT FLASHES CODE 12 TO INDICATE ELECTRONIC CONTROL MODULE SELF-DIAGNOSTIC ABILITY IS OK. IF MALFUNCTION CODES ARE PRESENT, THOSE CODES WILL FLASH *AFTER* CODE 12 FLASHES THREE TIMES

**EACH CODE FLASHES THREE TIMES**

9-21-92  
NS 14398

FLASHING "CHECK ENGINE" LIGHT → DIAGNOSTIC DISPLAY MODE

Each diagnostic chart uses 2 pages: a "trouble-tree chart" on the right side page, and a "facing page" on the left side page. The left side "facing page" contains pertinent information, including malfunction code setting parameters and circuit diagrams.

Troubleshooting is performed by using the "trouble-tree" page. Extra information, such as the reasoning behind certain tests, will be listed on the "facing" page.

**TROUBLE TREE BOXES WITH CIRCLED NUMBERS** (right side chart page)

are explained by the

**CORRESPONDING NUMBERED PARAGRAPH** (left side chart page)

**FACING PAGE**

**TROUBLE-TREE CHART PAGE**

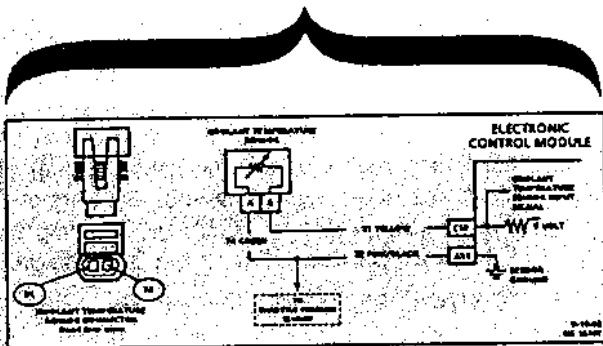

**CODE 14  
COOLANT TEMPERATURE  
(SIGNAL VOLTAGE TOO LOW)  
1.7L THROTTLE BODY INJECTION NIVA**

**Circuit Description:**

The coolant temperature sensor is a thermistor that controls the signal voltage to the electronic control module. The electronic control module applies about 3 volts on the Yellow wire from electronic control module terminal "C10" to the coolant temperature sensor, and "loads" it as the voltage drops. When the engine coolant is cold the sensor (thermistor) resistance is high, therefore the electronic control module will "see" high signal voltage.

As the engine warms, the coolant sensor (thermistor) resistance becomes less, and the electronic control module sees a lower signal voltage. At normal engine operating temperature (85°C-95°C) the voltage will remain about 1.3 to 2.0 volts.

**Test Description:** Number(s) below refer to circuit point(s) on the diagnostic chart.

- Code 14 will set if:
  - Engine has been running longer than 2 seconds.
  - AND
  - Coolant temperature sensor output signal voltage indicates engine coolant temperature is above 115°C.
- The test determines if the Circuit 31 Yellow wire from the coolant temperature sensor to electronic control module terminal "C10" is shorted to ground (low resistance) which will set a Code 14.

**Diagnostic Aids:**

The Tech 1 "Scan" tool displays engine temperature in degrees Celsius. After the engine is started, the temperature should rise steadily to about 85-95°C (but not higher) within the drive-cycle warm-up. Check resistance of the sensor for a good connection.

Refer to "Intermittents" in "Symptoms," Section "2.8B".

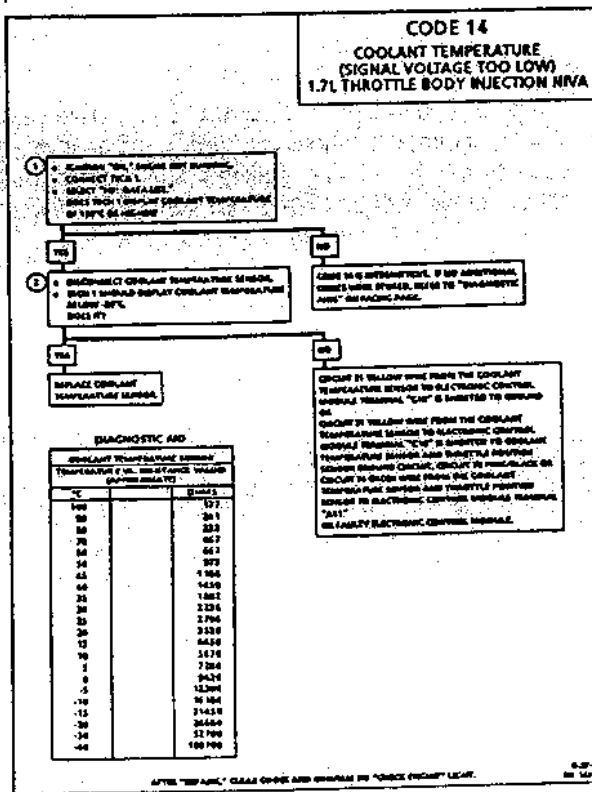

**DIAGNOSTIC AID**

COOLANT TEMPERATURE SENSOR

| TEMPERATURE (°C) | RESISTANCE (OHMS) |
|------------------|-------------------|
| 100              | 127               |
| 90               | 20.1              |
| 80               | 32.3              |
| 70               | 62.7              |
| 60               | 62.7              |
| 50               | 97.9              |
| 45               | 136.6             |
| 40               | 145.0             |
| 35               | 148.1             |
| 30               | 223.6             |
| 25               | 279.0             |
| 20               | 353.8             |
| 15               | 443.8             |
| 10               | 517.8             |
| 5                | 728.4             |
| 0                | 942.1             |
| -5               | 1230.1            |
| -10              | 1616.1            |
| -15              | 2143.1            |
| -20              | 2848.0            |
| -25              | 3779.0            |
| -30              | 5000.0            |

TYPICAL FACING PAGE

TYPICAL DIAGNOSTIC CHART

## 2.9A DIAGNOSTIC CHARTS

### TECH 1 "SCAN" TOOL TYPICAL DATA VALUE

The Tech 1 "Scan" Data listed in the table may be used for comparison, after completing the Diagnostic Circuit Check and finding the on-board diagnostics functioning properly and no diagnostic codes displayed.

**A TECH 1 "SCAN" TOOL THAT DISPLAYS FAULTY DATA SHOULD NOT BE USED, AND THE PROBLEM SHOULD BE REPORTED TO THE MANUFACTURER. THE USE OF A FAULTY TECH 1 "SCAN" TOOL CAN RESULT IN MISDIAGNOSIS AND UNNECESSARY PARTS REPLACEMENT.**

Only the parameters listed are used in this manual for diagnosing. For more description on the typical data values, to diagnosis electronic control module inputs, refer to the "General Description and System Operation," Section "1". If all data values are within the ranges illustrated, refer to "2-B" "Symptom Charts."

**Test Description:** Numbers below refer to circled numbers on the diagnostic chart.

1. The "Scan" position refers to the Tech 1 "FO: DATA LIST" display pairs that are displayed in order, if the "YES" button is pressed. After "Time From Start" parameter is displayed, by pressing the "YES" button, the display pairs will start on the top of list again.
2. "Units Displayed" are the available ways of displaying what each parameter is currently operating in, or a value that is being sensed or being outputted.
3. "Typical Data Value" is separated into two parts. These displayed values are typical of a normally operating vehicle. The ignition "ON" comparison should be performed first as this may lead to a quick identification of a failure. The Engine Running data should be compared to the ignition "ON" data as a diagnostic check to make sure the component or system is operating properly.
4. Ignition "ON" values are the typical values that should be seen on the Tech 1 "Scan" tool with the ignition "ON," and engine not running. Temperature sensors should be compared to the actual temperatures by letting the sensor sit overnight and then comparing their values. A difference of +5°C from the actual temperature may indicate a problem with the sensor. Use the diagnostic aids chart for that sensor to compare the resistance to temperature values.  
  
Some "ON" or "OFF" switches may display an abnormal state. If the chart states this position is abnormal, then this may be caused by an open or short to ground, depending upon the normal state of the switch. Refer to "General Description and Operation" Section "1" for more information.
5. "ENGINE RUNNING" typical data values are an average of display values recorded from normally operating vehicles, and are intended to represent what a normally functioning system would typically display.

| TECH 1 "SCAN" DATA            |                        |  |  |                  |
|-------------------------------|------------------------|--|--|------------------|
| ① "SCAN" POSITION             | ② UNITS DISPLAYED      | ③ TYPICAL DATA VALUE, A/C "OFF", ENGINE WARM |  | REFER TO SECTION |
|                               |                        | ④ IGNITION "ON"                              | ⑤ ENGINE IDLING  |                  |
| ENGINE SPEED                  | REVOLUTIONS PER MINUTE | 0  | ± 50 FROM DESIRED IDLE   | 1.2              |
| DESIRED IDLE                  | REVOLUTIONS PER MINUTE | VARIES                                       | ELECTRONIC CONTROL MODULE IDLE COMMAND (VARIES WITH TEMPERATURE) | 1.2              |
| COOLANT TEMPERATURE           | °C                     | SHOULD EQUAL ACTUAL TEMP.                    | 85° - 110°C  | 1.1              |
| INTAKE AIR TEMPERATURE        | °C                     |  | VARIES WITH AMBIENT AND UNDERHOOD AIR TEMPERATURE                | 1.1              |
| MANIFOLD ABSOLUTE PRESSURE    | KPA/VOLTS              | 75 TO 105 KPA<br>3.5 TO 5.0 VOLTS            | DEPENDS ON BAROMETRIC PRESSURE AND ENGINE LOAD                   | 1.1              |
| BAROMETRIC PRESSURE           | KPA                    | VARIES WITH ALTITUDE                         | DEPENDS ON BAROMETRIC PRESSURE                                   | 1.1              |
| THROTTLE POSITION             | VOLTS                  | .35 - .70                                    | .35 - .70  | 1.1              |
| THROTTLE ANGLE                | 0-100%                 | 0%   | 0%   | 1.1              |
| VEHICLE SPEED                 | KILOMETERS PER HOUR    | 0  | 0  | 1.1              |
| SYSTEM VOLTAGE                | VOLTS                  | 11.5 - 14.0                                  | 12.0 - 15.0  | 1.2              |
| OXYGEN SENSOR VOLTAGE         | MILLIVOLTS             | LESS THAN 200 mV                             | 95mV to 950mV  | 1.1              |
| OPEN/CLOSED LOOP FUEL CONTROL | OPEN/CLOSED            | OPEN   | "CLOSED LOOP" WITHIN 5 MINUTES AFTER STARTING ENGINE             | 1.2              |
| POWER ENRICHMENT MODE ACTIVE  | YES/NO                 | NO   | NO   | 1.2              |
| OXYGEN SENSOR READY           | YES/NO                 | YES  | SHOULD REMAIN "YES" AFTER STARTING ENGINE                        | 1.1              |
| EXHAUST GASES                 | RICH/LEAN              | LEAN   | VARIES WITH OXYGEN SENSOR'S INTERPRETATION OF EXHAUST GASES      | 1.1              |
| DECEL FUEL CUT MODE IN EFFECT | YES/NO                 | NO   | NO   | 1.2              |

4-27-93  
NS 14408

## 2-34 ENGINE MANAGEMENT SYSTEMS 1.7L THROTTLE BODY INJECTION

| TECH 1 "SCAN" DATA                             |   |   |  |                  |
|--|---|---|--|------------------|
| ① "SCAN" POSITION                              | ② UNITS DISPLAYED                                     | ③ TYPICAL DATA VALUE, A/C "OFF" ENGINE WARM |  | REFER TO SECTION |
|  |   | ④ IGNITION "ON"                             | ⑤ ENGINE IDLING  |                  |
| ADAPTIVE MEMORY FUEL ADJUSTMENT                | - 100% -<br>+ 100%                                    | 0%  | FLUCTUATES WITH CHANGE IN MEMORY FUEL ADJUSTMENT NORMALLY BETWEEN -10% AND + 10%                                       | 1.2              |
| FUEL MEMORY CELL                               | 0-35  |   | 35   | 1.2              |
| "CLOSED LOOP" FUEL ADJUSTMENT                  | - 100% -<br>+ 100%                                    | 0%  | FLUCTUATES WITH CHANGE IN "CLOSED LOOP" FUEL ADJUSTMENT NORMALLY BETWEEN -20% AND +20% WHEN OPERATING IN "CLOSED LOOP" | 1.2              |
| SPARK ADVANCE                                  | 0 BEFORE TOP DEAD CENTER TO 60 BEFORE TOP DEAD CENTER | NOT USEABLE                                 | VARIES   | 1.4              |
| FUEL INJECTOR PULSE WIDTH                      | MILLISECONDS  | 3.9 OR HIGHER                               | .8 TO 1.5  | 1.2              |
| AIR FUEL RATIO                                 |   | NOT USEABLE                                 | 13.5 - 14.7  | 1                |
| CALIBRATION IDENTIFICATION                     | VARIES  | VARIES                                      | VARIES   | 1.1              |
| ENGINE RUNNING TIME SINCE LAST START UP        | HOURS/MINUTES/<br>SECONDS                             | NOT USEABLE                                 | VARIES WITH TIME   | 2.3              |
| IDLE AIR CONTROL POSITION                      | COUNTS  | 135   | 5-50   | 1.2              |
| AIR CONDITIONING REQUEST SIGNAL                | YES/NO  | NO  | CHANGES WITH REQUEST FOR AIR CONDITIONING  | 1.1              |
| AIR CONDITIONING COMPRESSOR CONTROL RELAY      | ON/OFF  | OFF   | CHANGES WITH COMPRESSOR STATUS   | 1.1              |
| OCTANE ADJUSTMENT                              | VOLTS<br>DEGREES                                      | 0.00 VOLT<br>0° TO -8°                      | 1.0 VOLT TO 4.7 VOLT<br>0° TO -8°  | 1.1              |
| EVAPORATIVE EMISSION CANISTER PURGE DUTY CYCLE | 0 - 100%  | 0%  | 0%   | 1.3              |
| INTAKE MANIFOLD HEATER CONTROL RELAY           | OFF/ON  | OFF   | "ON" OR "OFF" DEPENDING ON COOLANT TEMPERATURE AND INTAKE AIR TEMPERATURE  | 1.9              |
| FUEL PUMP CIRCUIT                              | ON/OFF  | "ON"<br>MOMENTARILY<br>THEN "OFF"           | "ON"   | 1.2              |
| RADIATOR FAN                                   | NOT USED  | NOT USED                                    |  | 1.2              |

4-27-93  
NS 14409

## ELECTRONIC CONTROL MODULE DIAGNOSTIC CODES

| CODE | DESCRIPTION   | TURN ON CHECK ENGINE LIGHT? |
|------|---|-----------------------------|
| 13   | NO OXYGEN SENSOR SIGNAL   | YES                         |
| 14   | COOLANT TEMPERATURE - Signal voltage too low                    | YES                         |
| 15   | COOLANT TEMPERATURE - Signal voltage too high                   | YES                         |
| 21   | THROTTLE POSITION - Signal voltage too high                     | YES                         |
| 22   | THROTTLE POSITION - Signal voltage too low                      | YES                         |
| 23   | INTAKE AIR TEMPERATURE - Signal voltage too high                | YES                         |
| 24   | NO VEHICLE SPEED SIGNAL   | YES                         |
| 25   | INTAKE AIR TEMPERATURE - Signal voltage too low                 | YES                         |
| 33   | MANIFOLD ABSOLUTE PRESSURE - Signal voltage too high            | YES                         |
| 34   | MANIFOLD ABSOLUTE PRESSURE - Signal voltage too low             | YES                         |
| 35   | IDLE SPEED ERROR  | YES                         |
| 42   | ELECTRONIC SPARK TIMING - Control Circuit problem               | YES                         |
| 44   | LEAN EXHAUST INDICATION   | YES                         |
| 45   | RICH EXHAUST INDICATION   | YES                         |
| 51   | CALIBRATOR ERROR  | YES                         |
| 53   | SYSTEM VOLTAGE TOO HIGH   | YES                         |
| 54   | OCTANE ADJUSTMENT CIRCUITS - Signal voltage too high or too low | YES                         |
| 55   | ELECTRONIC CONTROL MODULE ERROR                                 | YES                         |

6-5-92  
NS 14410

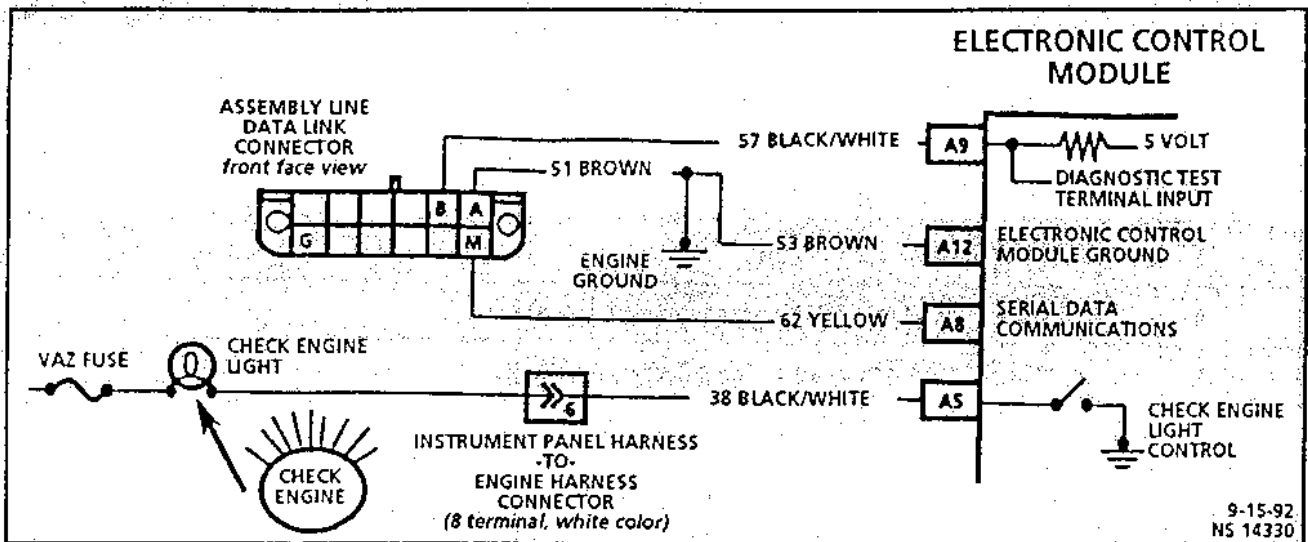

**CHART A**  
**DIAGNOSTIC CIRCUIT CHECK**  
**1,7L THROTTLE BODY INJECTION NIVA**

**Circuit Description:**

The diagnostic circuit check is an organized approach to identifying a problem created by an electronic engine control system malfunction. It must be the starting point for any driveability complaint diagnosis, because it directs the service technician to the next logical step in diagnosing the complaint. Understanding the chart and using it correctly will reduce diagnosis time and prevent the unnecessary replacement of good parts.

**Test Description:** Number(s) below refer to circled number(s) on the diagnostic chart.

1. This check is to see if the bulb is OK.
2. If the "Check Engine" light is "OFF," CHART A-1 will check for both ignition feed and constant battery power to the electronic control module and the electronic control module grounds.
3. This check is done to see if the electronic control module has the capability to control the "Check Engine" light. With the assembly line data link diagnostic "test" terminal "B" grounded, the "Check Engine" light will flash Code 12 at least three times followed by any diagnostic codes stored in memory. Code 12 means there is no crankshaft reference signal coming to the electronic control module, this is normal because the engine is not running.
4. This check is used to see if the electronic control module can supply serial data for Tech 1 "Scan" tool use. If an engine calibrator error is present, the electronic control module may have the ability to flash a Code 12 but not enable serial data.
5. This test is used to see if "Cranks But Will Not Run" symptom is caused by an electronic control module problem or the vehicle electrical system.
6. This check is to see if the electronic control module has any codes stored in its memory to aid in diagnosing the customer complaint.
7. Look at all the parameters to determine if one is not in a normal state with just the ignition "ON" and engine not running. In particular, look at the barometric pressure reading from the manifold absolute pressure sensor voltage and kPa values. Are they normal for your altitude, use CHART C1-D. Look at the coolant temperature sensor value to see if the value is reasonable or if it is shifted above or below where it should be.
8. If the actual data is not within the typical values established, the charts in Section "2-C" "Component Systems Charts" will provide a functional check of the suspect component or system.

**Diagnostic Aids:**

If assembly line data link serial data output circuit (Yellow, wire from electronic control module terminal "A8" to assembly line data link terminal "M") is shorted to +12V, there will be no serial data output. See CHART A-2.



## CHART A DIAGNOSTIC CIRCUIT CHECK 1,7L THROTTLE BODY INJECTION NIVA

- IGNITION "ON," ENGINE NOT RUNNING.
- NOTE CHECK ENGINE LIGHT.

1 STEADY LIGHT

2 NO LIGHT

FLASHING CODE 12

3 • JUMPER ASSEMBLY LINE DATA LINK TERMINAL "B" TO "A". DOES CHECK ENGINE LIGHT FLASH CODE 12 AT LEAST 3 TIMES?

CHECK FOR GROUNDED DIAGNOSTIC TEST INPUT CIRCUIT (BLACK/WHITE WIRE) TO ELECTRONIC CONTROL MODULE TERMINAL "A9". USE WIRING DIAGRAM ON CHART A.

USE CHART A-1

USE CHART A-2

4 YES

NO

5 YES

NO

WILL ENGINE START AND RUN?

USE CHART A-2

YES

NO

6 • ON TECH 1 TOOL, USE "EXIT" KEY AND RETURN TO SCREEN TITLED "SELECT MODE ↑ ↓". NEXT, SELECT F2: TROUBLE CODE. ARE ANY TROUBLE CODES DISPLAYED?

USE CHART A-3

YES

NO

REFER TO APPLICABLE CODE CHART. IF MORE THAN ONE CODE IS DISPLAYED, START WITH LOWEST CODE NUMBER.

7 • ON TECH 1 TOOL, PRESS "EXIT" KEY ONCE, THEN SELECT F8: DATA LIST.  
• COMPARE EACH TECH 1 PARAMETER WITH TYPICAL DATA VALUES SHOWN ON PREVIOUS 4 PAGES. ARE VALUES NORMAL AND/OR WITHIN TYPICAL RANGES?

YES

NO

REFER TO: "SYMPTOM CHARTS," SECTION 2.

8 REFER TO: "COMPONENT SYSTEMS CHARTS," SECTION 2.

4-27-93  
NS 14331

## 2-38 ENGINE MANAGEMENT SYSTEMS 1.7L THROTTLE BODY INJECTION

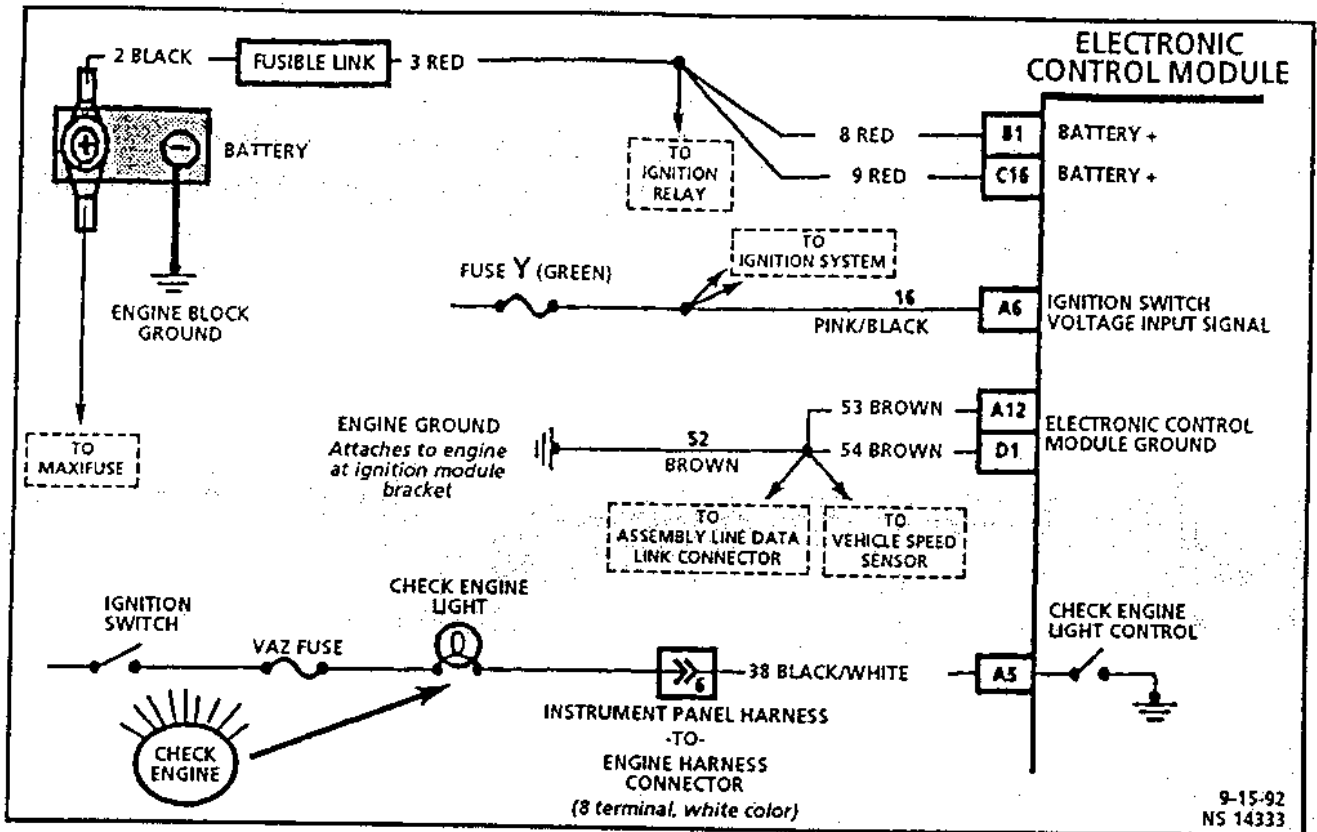

### CHART A-1 NO "CHECK ENGINE" LIGHT 1.7L THROTTLE BODY INJECTION NIVA

#### Circuit Description:

There should always be a steady "Check Engine" light, when the ignition is "ON" and the engine is not running. Switched ignition voltage is supplied from VAZ fuse directly to the light bulb. The electronic control module will control the light and turn it "ON" by providing a ground path through the Black/White wire to electronic control module terminal "A5".

**Test Description:** Number(s) below refer to circled number(s) on the diagnostic chart.

1. Step 1 checks the operation of the control circuit wire to the electronic control module connector terminal "A5".
2. This step checks the electronic control module is receiving power on its three power supply terminals: "B1", "C16", and "A6".
3. This step checks the electronic control module-to-engine block ground circuits on electronic control module connector terminals "A12" and "D1".

#### Diagnostic Aids:

If ignition switch voltage input circuit (electronic control module Pink/Black wire from electronic control module terminal "A6" to Fuse "Y") is shorted to voltage the engine will not stop running and/or the dash lights will be "ON."

If the "Check Engine" light is "OFF" and the test light is "ON" in Step 1, there may be a short to 12 volts between "A5" and the "Check Engine" light. Check for open wires, bad connections or a bad bulb before assuming that there is a short to 12 volts.

**CHART A-1**  
**NO "CHECK ENGINE" LIGHT**  
**1.7L THROTTLE BODY INJECTION NIVA**

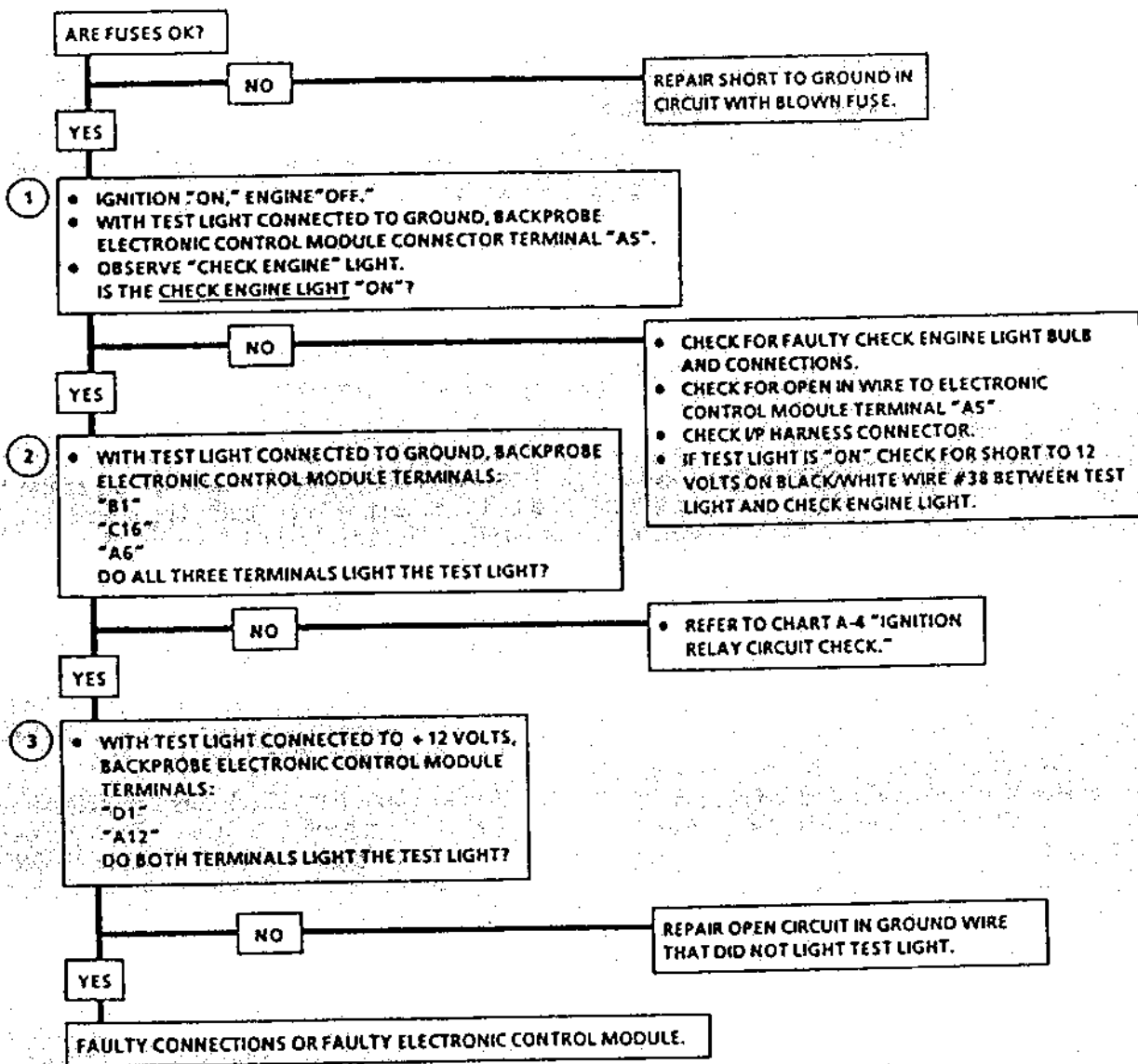

4-27-93  
 NS 14334

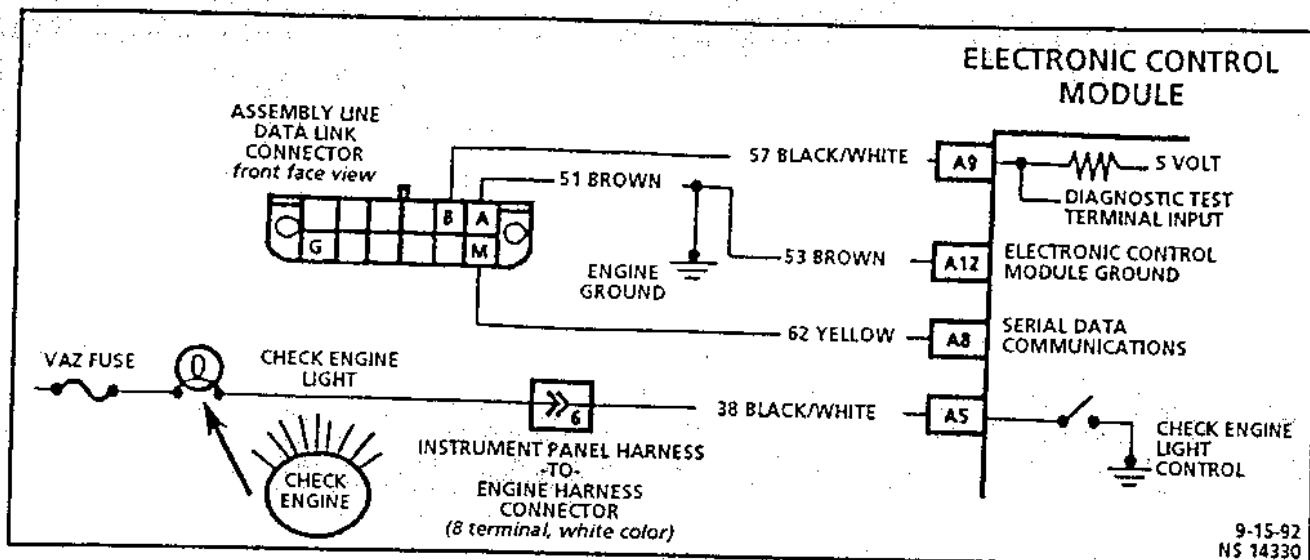

**CHART A-2**  
**NO ASSEMBLY LINE DATA LINK SERIAL DATA**  
**OR**  
**WILL NOT FLASH CODE 12**  
**("CHECK ENGINE" LIGHT "ON" STEADY)**  
**1.7L THROTTLE BODY INJECTION NIVA**

**Circuit Description:**

There should always be a steady "Check Engine" light when the ignition switch is "ON" and the engine is not running. Switched ignition voltage is supplied directly to the "Check Engine" light bulb. The electronic control module will turn the light "ON" by supplying the ground path on electronic control module terminal "A5".

When the electronic control module's diagnostic "test" terminal "A9" is grounded, the electronic control module commands the "Check Engine" light to flash a Code 12, followed by any code(s) stored in memory. The Tech 1 "Scan" tool, when the "F1: Field Service" key is pressed, supplies a ground for assembly line data link terminal "B".

**Test Description:** Number(s) below refer to circled number(s) on the diagnostic chart.

1. If "Check Engine" light is "ON," but very dim and the engine will not start, check connections "D1" and "A12" for proper tightness. Also, ensure that they are clean.
2. If the "Check Engine" light goes "OFF" when the electronic control module connectors are disconnected, then the "Check Engine" light control circuit 38 (Black/White wire) to electronic control module terminal "A5" is not shorted to ground.
3. The electronic control module can flash a Code 12 but may not be able to output serial data to the assembly line data link connector terminal "M". If the Tech 1 "Scan" tool does not display serial data AND the "Check Engine" light is flashing Code 12, THEN check the Tech 1 "Scan" tool on a good vehicle. If the Tech 1 "Scan" tool and the serial data output circuit are OK, then the connections, the electronic control module, or the engine calibrator may be faulty.
4. This step checks for an open circuit between assembly line data link connector terminal "B" and electronic control module terminal "A9".
5. At this point, the "Check Engine" light wiring is OK. The problem is a faulty electronic control module or engine calibrator. If Code 12 does not flash after replacing the electronic control module, then replace the engine calibrator also.

**Diagnostic Aids:**

A steady light suggests a short to ground in the "Check Engine" light control circuit, or an open in the diagnostic test terminal input circuit to the electronic control module.

**CHART A-2**  
**NO ASSEMBLY LINE DATA LINK SERIAL DATA**  
**OR**  
**WILL NOT FLASH CODE 12**  
**("CHECK ENGINE" LIGHT "ON" STEADY)**  
**1.7L THROTTLE BODY INJECTION NIVA**

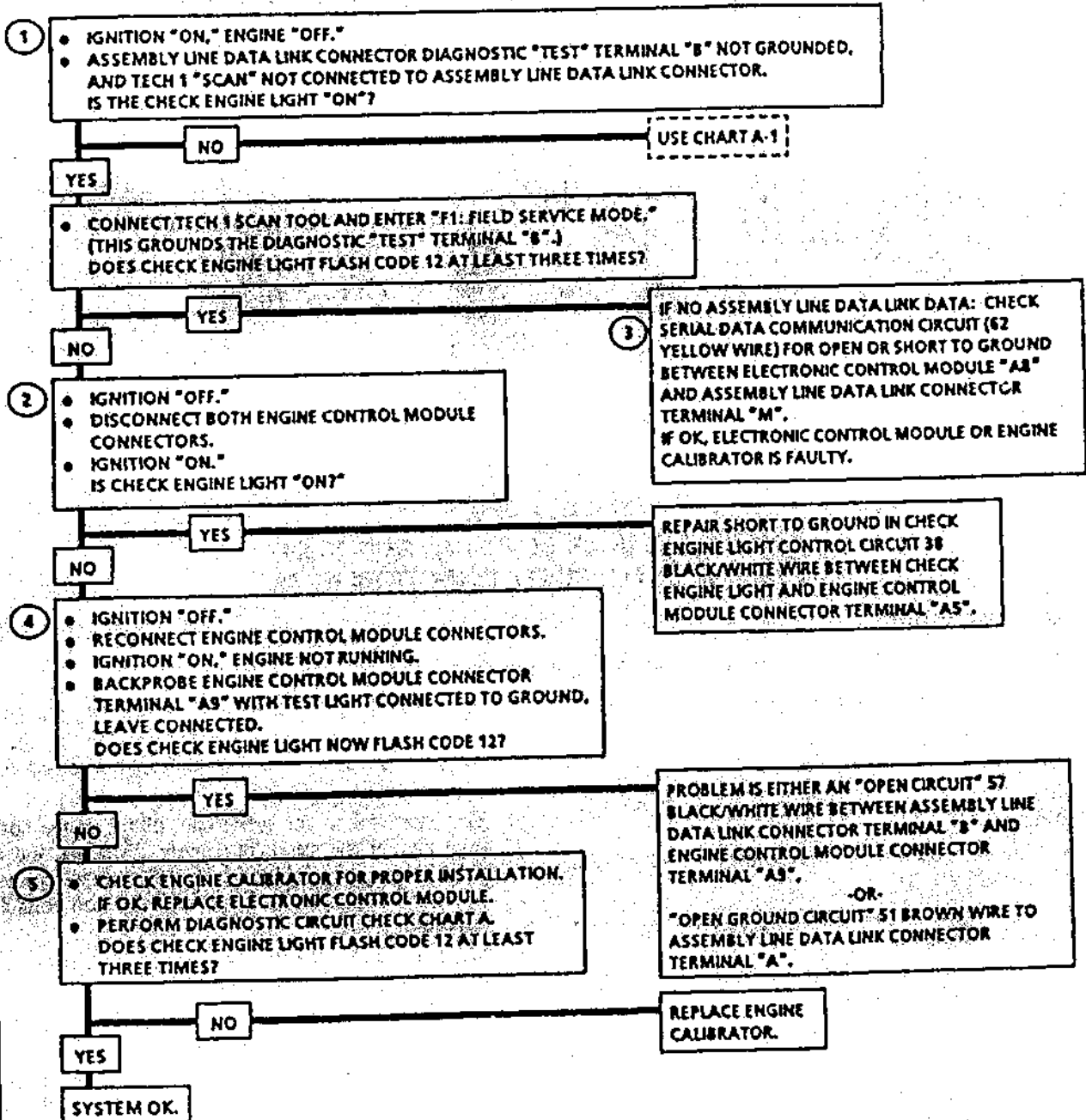

## 2-42 ENGINE MANAGEMENT SYSTEMS 1.7L THROTTLE BODY INJECTION

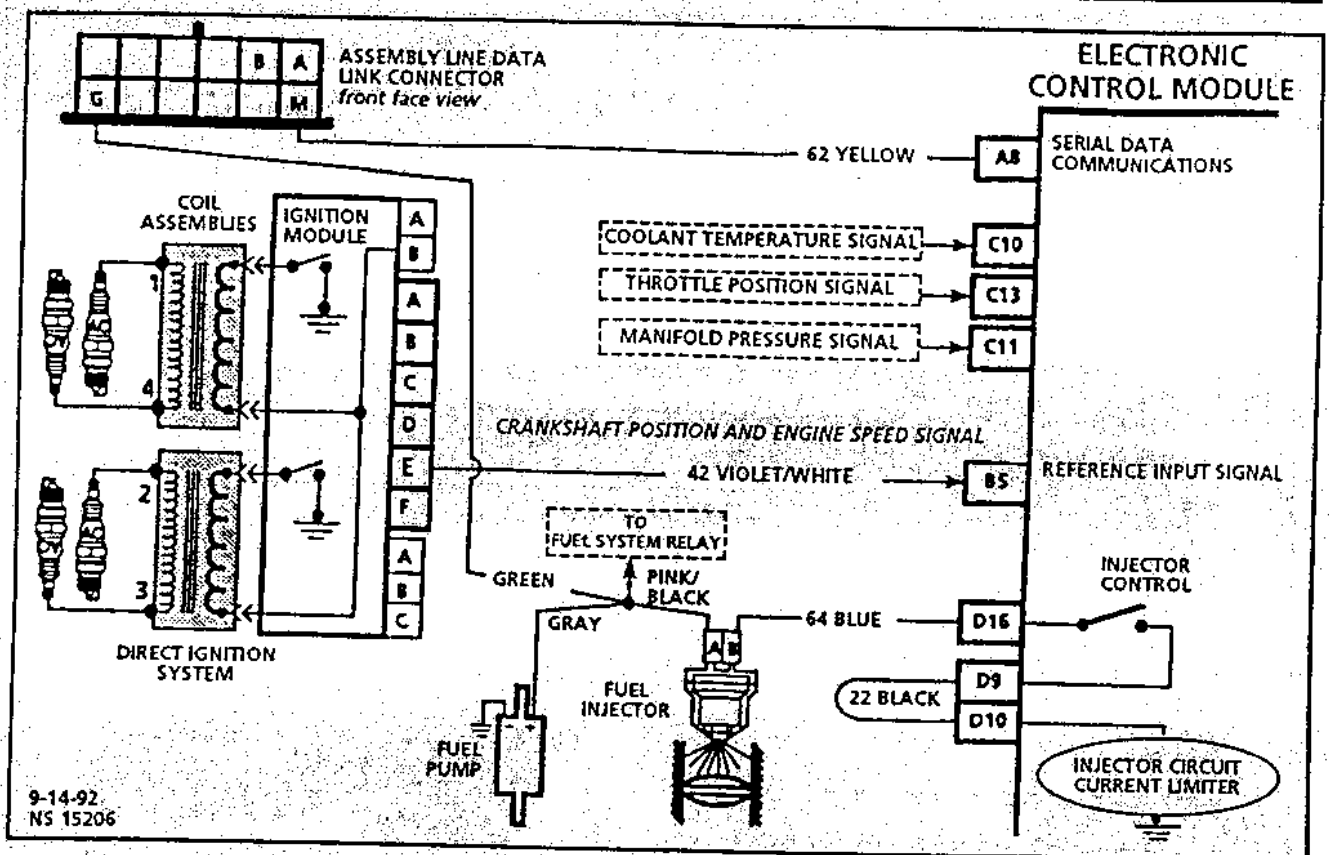

### CHART A-3

(Page 1 of 3)

### ENGINE CRANKS BUT WILL NOT RUN 1.7L THROTTLE BODY INJECTION NIVA

#### Circuit Description:

Before using this chart check: battery condition, engine cranking speed, fuel quantity and quality

**Test Description:** Number(s) below refer to circled number(s) on the diagnostic chart.

- It is essential that CHART A, "Diagnostic Circuit Check" be performed first. CHART A will determine if:
  - Electronic control module power and ground circuits are OK.
  - Electronic control module self diagnostic ability is operating.
  - Tech 1 "Scan" tool can communicate with the electronic control module.
- If incorrect, these sensor input signals to the electronic control module can cause a no-start.
- Any time the electronic control module has been "OFF" for at least 15 seconds, it energizes the fuel pump relay for 2 seconds after the ignition switch is turned "ON." If the engine is not cranked, the electronic control module turns the relay "OFF" after 2 seconds. Have an assistant listen for fuel pump running at the rear of vehicle.
- This step checks for sufficient voltage at the spark plug end of the spark plug wire. Wire #1 and #2 must be tested individually. Wire #1 and #2 connect to different ignition coils, so both ignition coils are checked.
- With the fuel injector electrically disconnected, there should be NO fuel delivered.
- This step checks for a short to ground on the injector control circuit. If this occurs, the engine would be "flooded" because the injector would spray fuel continuously, without electronic control module control.

**CHART A-3**  
 (Page 1 of 3)  
**ENGINE CRANKS BUT WILL NOT RUN**  
**1.7L THROTTLE BODY INJECTION NIVA**

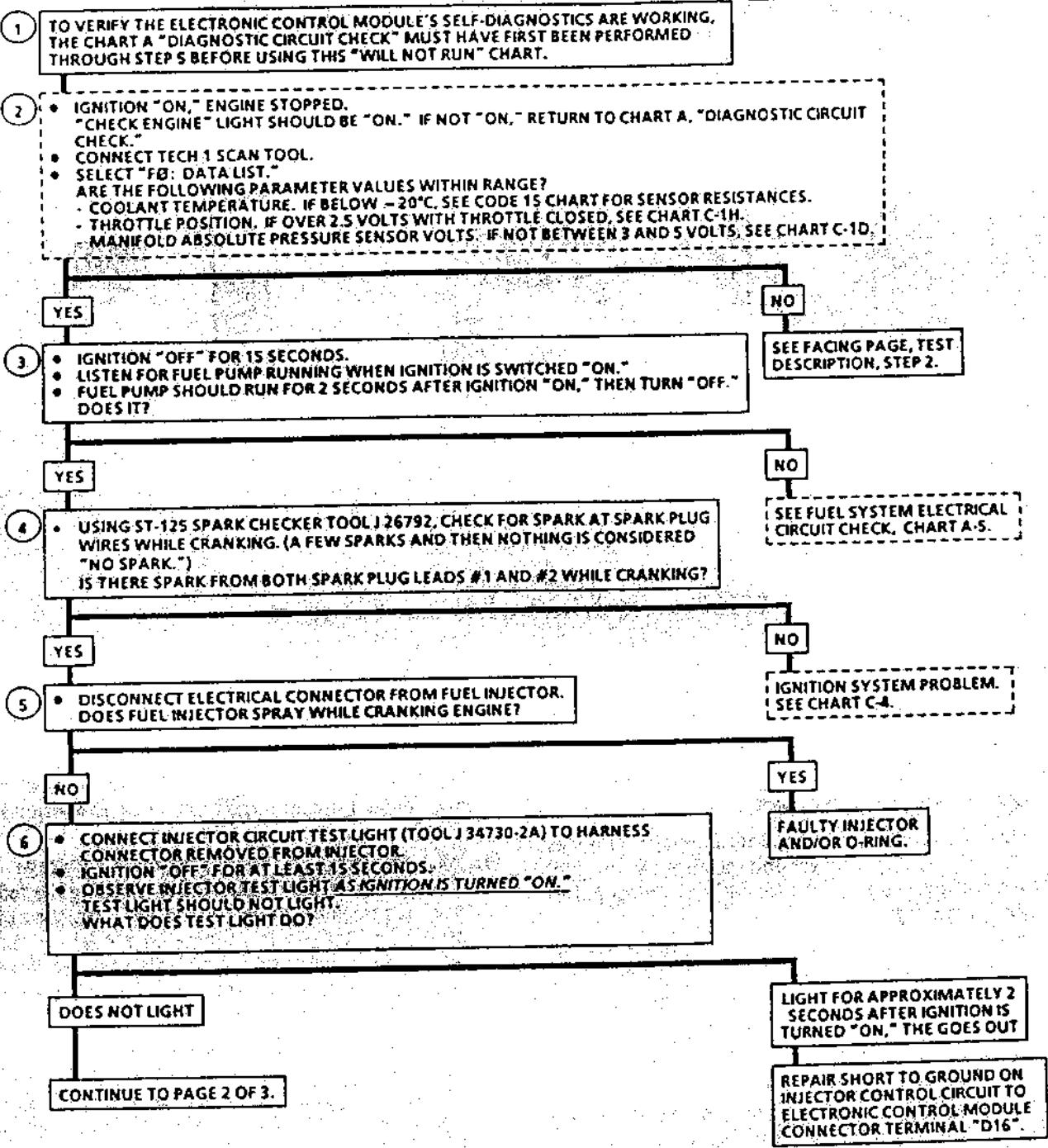

4-27-93  
 NS 15801

## 2-44 ENGINE MANAGEMENT SYSTEMS 1.7L THROTTLE BODY INJECTION

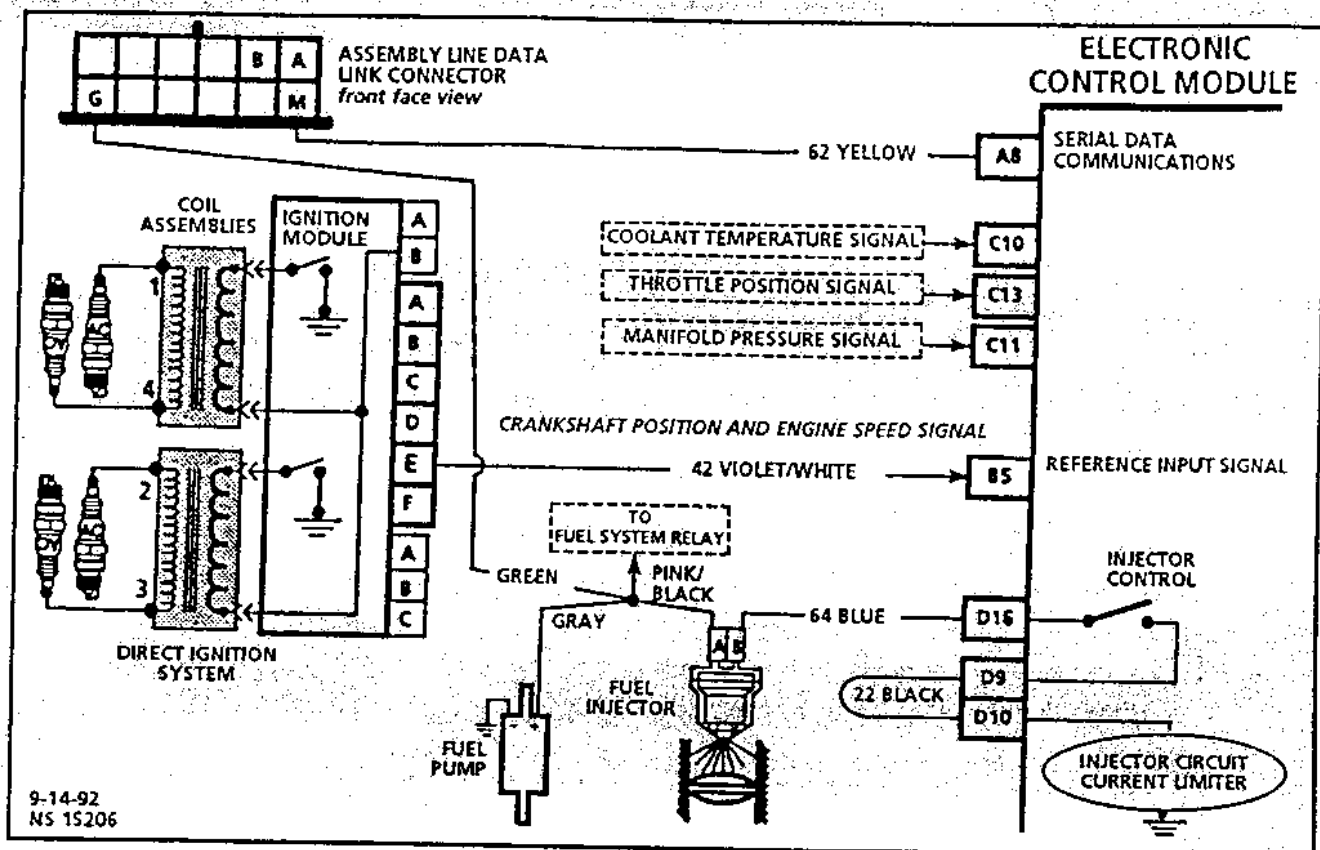

### CHART A-3

(Page 2 of 3)

### ENGINE CRANKS BUT WILL NOT RUN 1.7L THROTTLE BODY INJECTION NIVA

#### Circuit Description:

Before using this chart check: battery condition, engine cranking speed, fuel quantity and quality.

**Test Description:** Numbers (s) below refer to circled number(s) on the diagnostic chart.

7. The electronic control module normally provides electrical pulses (to ground) to operate the fuel injector. This step checks for these electrical pulses while cranking.
8. This step checks for fuel spray when the injector receives the electrical pulses verified in Step 7. If there is fuel spray, see the next (bottom) box for possible causes of a "WILL NOT RUN."
9. Incorrect fuel pressure can cause a "WILL NOT RUN." If fuel pressure is OK, the injector is faulty.
10. The electronic control module must receive "reference signal input" pulses from the ignition system, to calculate any "engine running" functions. The Tech 1 will show the engine speed if the electronic control module is receiving this reference signal.

**NOTICE:** If engine speed is indicated but less than 80, check for and repair cause of low cranking speed.

11. With the test light connected to "+" voltage, by quickly, repeatedly, momentarily touching the reference signal wire going to the electronic control module a "substitute" source of signal pulses is being generated. If the Tech 1 displays any engine speed above zero, the signal is being received and interpreted by the electronic control module.
12. Jumpering the + battery terminal to pin "G" will power the injector with + voltage. (See main wiring diagrams, page 2 of 5, located in Section 2 of this manual.) At the injector harness connector, only the Pink/Black wire should have voltage to light the test light.



**CHART A-3**  
(Page 2 of 3)  
**ENGINE CRANKS BUT WILL NOT RUN**  
**1.7L THROTTLE BODY INJECTION NIVA**

CONTINUED FROM PAGE 1 OF 3

7 • WATCH INJECTOR TEST LIGHT WHILE CRANKING THE ENGINE. DOES TEST LIGHT BLINK?

NO YES

8 • REMOVE INJECTOR TEST LIGHT FROM HARNESS CONNECTOR. • RECONNECT HARNESS CONNECTOR TO INJECTOR. • LOOK FOR FUEL SPRAY FROM INJECTOR. DOES FUEL SPRAY WHILE CRANKING ENGINE?

YES

9 NO

• CHECK FOR:  
- FOULED SPARK PLUGS.  
- RESTRICTED EXHAUST SYSTEM. REFER TO CHART B-1.  
- INCORRECT FUEL OR WATER/FOREIGN MATERIAL IN FUEL.  
- SPARK PLUG WIRES "CROSSED," CONNECTED INTO WRONG SPARK PLUGS.  
- INCORRECT FUEL PRESSURE. REFER TO CHART A-7.  
- CAMSHAFT TIMING CHAIN SLIPPED OR STRIPPED.  
- INADEQUATE ENGINE COMPRESSION.

• IGNITION "OFF."  
• INSTALL FUEL PRESSURE GAGE. (SEE CHART A-7 TO DETERMINE WHERE TO CONNECT FUEL PRESSURE GAGE).  
• IGNITION "ON."  
• FUEL PRESSURE SHOULD BE 190 TO 210 kPa (27.6 TO 30.5 PSI, 1.9 - 2.1 BAR). IS IT?

YES

NO

FAULTY INJECTOR. CHECK FOR SHORT TO GROUND IN ELECTRONIC CONTROL MODULE TERMINAL "D9" AND "D10" CIRCUIT.

REFER TO "FUEL SYSTEM DIAGNOSIS," CHART A-7.

10 • INSTALL TECH 1. SELECT "FO: DATA LIST." • MONITOR "ENGINE SPEED" WHILE HOLDING THE IGNITION SWITCH KEY IN THE "START" POSITION. IS ENGINE SPEED INDICATING MORE THAN 80 WHILE CRANKING?

YES

11 NO

12 • DISCONNECT TECH 1 SCAN TOOL. • WITH A FUSED JUMPER WIRE, JUMPER THE "+" BATTERY TERMINAL TO PIN "G" OF THE ASSEMBLY LINE DATA LINK CONNECTOR. • IGNITION "ON," DISCONNECT FUEL INJECTOR. • WITH A TEST LIGHT CONNECTED TO GROUND, TOUCH EACH OF THE 2 TERMINALS OF THE DISCONNECTED INJECTOR HARNESS CONNECTOR. • OBSERVE TEST LIGHT ON EACH TERMINAL.

• DISCONNECT 6 PIN HARNESS CONNECTOR FROM IGNITION MODULE. • IGNITION "ON."  
• CONNECT TEST LIGHT CLIP LEAD TO "+" BATTERY TERMINAL. • OBSERVE TECH 1 "ENGINE SPEED" WHILE USING TEST LIGHT TO QUICKLY AND REPEATEDLY TOUCH TERMINAL "E" OF 6 PIN HARNESS CONNECTOR REMOVED FROM IGNITION MODULE. • TECH 1 SHOULD INDICATE AN ENGINE SPEED ABOVE ZERO. DOES IT?

YES

NO

FAULTY CONNECTION OR DEFECTIVE IGNITION MODULE.

PROBLEM IS EITHER A CIRCUIT FAULT ON THE "REFERENCE INPUT SIGNAL" VIOLET/WHITE WIRE BETWEEN 6 PIN IGNITION MODULE CONNECTOR TERMINAL "E" TO ELECTRONIC CONTROL MODULE TERMINAL "85," OR A DEFECTIVE ELECTRONIC CONTROL MODULE. VERIFY THAT NO CIRCUIT FAULT (OPEN, SHORT TO GROUND, SHORT TO VOLTAGE) IS PRESENT BEFORE REPLACING ELECTRONIC CONTROL MODULE.

LIGHT "ON" ONE TERMINAL ONLY

NO LIGHT EITHER TERMINAL

LIGHT "ON," BOTH TERMINALS

DISCONNECT FUSED JUMPER WIRE FROM DATA LINK CONNECTOR

REPAIR OPEN CIRCUIT IN PINK/BLACK "POWER SUPPLY" WIRE TO INJECTOR.

REPAIR SHORT TO VOLTAGE ON BLUE "INJECTOR CONTROL CIRCUIT" WIRE.

## 2-46 ENGINE MANAGEMENT SYSTEMS 1.7L THROTTLE BODY INJECTION

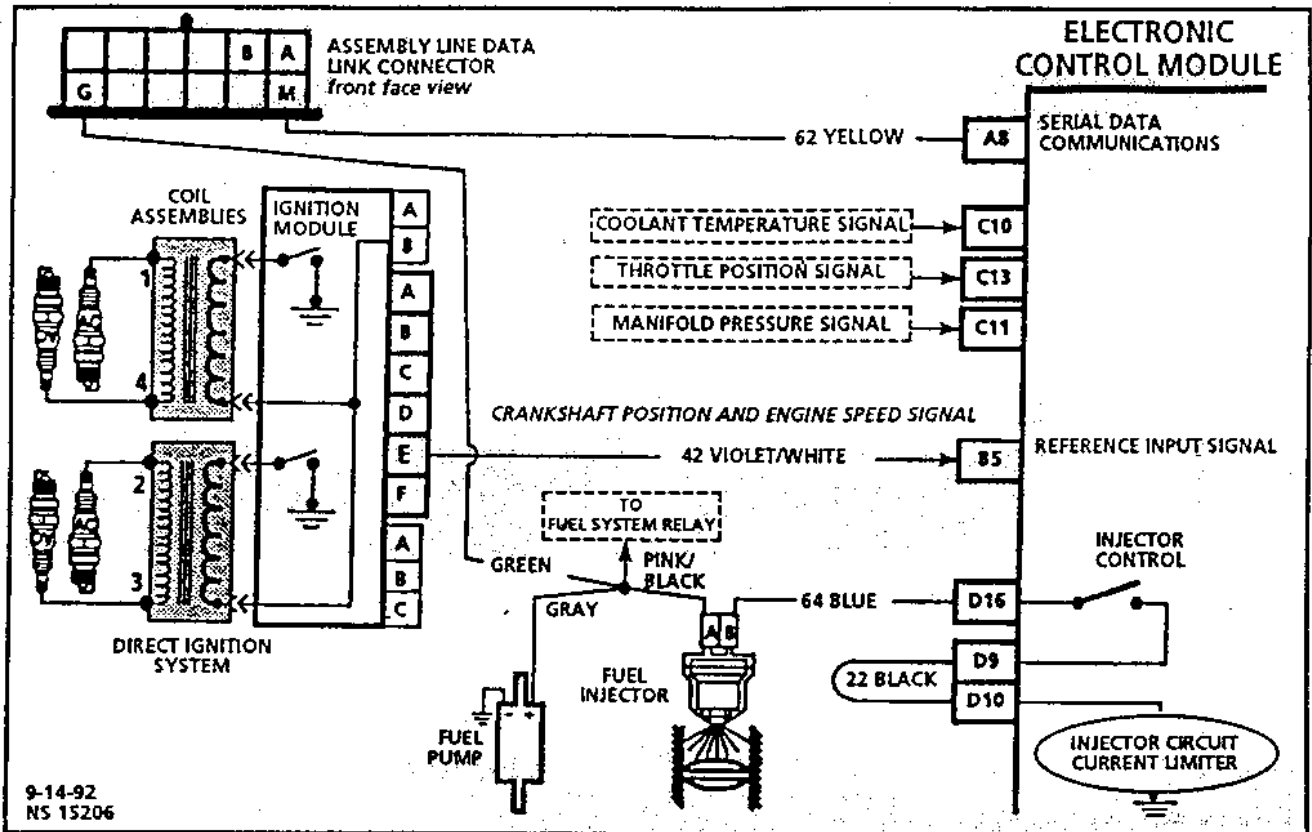

### CHART A-3

(Page 3 of 3)

### ENGINE CRANKS BUT WILL NOT RUN 1.7L THROTTLE BODY INJECTION NIVA

#### Circuit Description:

Before using this chart check: battery condition, engine cranking speed, fuel quantity and quality.

**Test Description:** Number(s) below refer to circled number(s) on the diagnostic chart.

- If the engine is too cold or too hot to properly test the fuel injector, the test results would be invalid. It is imperative for accurate test results that the injector temperature is between 10°C and 35°C.
- This test uses the fuel injector tester J 39021 and the digital voltmeter J 39689 together. The injector tester supplies one of three fixed amperage current values throughout the duration of the test. Selection of the correct supply amperage value of 4 amps is based on the injector coil's specified resistance when the push-to-test button is depressed. The tester energizes the injector solenoid coil for 5 seconds.

The condition of the injector solenoid coil is determined by the voltage displayed on the digital voltmeter while the injector is energized. The voltage reading displayed during the first second of the five second test should be ignored.

- This step checks that the injector control circuit (Blue #64 wire) is a complete circuit to the electronic control module. With the injector connected, the voltage from the Pink/Blue injector wire goes through the injector, and through the Blue #64 wire to the electronic control module terminal "D16".
- Electronic control module terminals "D9" and "D10" are connected by a loop of wire in the harness. If this loop breaks open, the injector control circuits inside the electronic control module damage could result. If circuit is shorted to voltage (+12 volts), the engine will not start.

**CHART A-3**  
 (Page 3 of 3)  
**ENGINE CRANKS BUT WILL NOT RUN**  
**1.7L THROTTLE BODY INJECTION NIVA**

FROM CHART A-3  
 PAGE 2 OF 3

FUEL INJECTOR TEST TO BE PERFORMED NEXT, WITH ENGINE TEMPERATURE BETWEEN 10°C AND 35°C FOR ACCURATE INJECTOR TEST.

- 13
- IGNITION "ON".
  - CONNECT TECH 1. SELECT "F0: DATA LIST". OBSERVE COOLANT TEMPERATURE.
  - IS COOLANT TEMPERATURE BETWEEN 10°C AND 35°C?

NO — INJECTOR MUST BE TESTED AT TEMPERATURES BETWEEN 10°C AND 35°C. ALLOW THE ENGINE TO WARM OR COOL AS NEEDED.

YES —

- IGNITION "OFF".
- CONNECT FUEL INJECTOR TESTER J-39021 POWER CABLE TO VEHICLE BATTERY. SET THE TESTER ROTARY SWITCH TO THE "INJECTOR COIL TEST, 4 AMP" POSITION.
- PLUG DIGITAL VOLTMETER J-39689 TEST LEADS (+/-) INTO FUEL INJECTOR TESTER. SET THE DIGITAL VOLTMETER TO MEASURE "DC VOLTS."
- DISCONNECT HARNESS CONNECTOR FROM FUEL INJECTOR. USING TESTER ADAPTOR J-39021-30, CONNECT FUEL INJECTOR TESTER CABLE TO FUEL INJECTOR.
- FUEL INJECTOR TESTER "LOW VEHICLE BATTERY" INDICATOR SHOULD NOT BE "ON". IS IT?

YES — CHARGE VEHICLE BATTERY BEFORE PROCEEDING.

NO —

- 14
- OBSERVE VOLT METER. AS INJECTOR TESTER "START TEST" BUTTON IS PUSHED ONCE. (INJECTOR WILL AUTOMATICALLY BE TESTED FOR 5 SECONDS. DO NOT TEST MORE OFTEN THAN ONCE PER MINUTE)
  - VOLTAGE DISPLAYED SHOULD STAY BETWEEN 5.4 AND 8.5 VOLTS DC. (DISREGARD FIRST SECOND OF THE 5-SECOND TEST.) DOES VOLTAGE STAY BETWEEN 5.4 AND 8.5 VOLTS?

NO — FAULTY FUEL INJECTOR.

YES —

- 15
- DISCONNECT TESTERS, AND RECONNECT HARNESS TO FUEL INJECTOR.
  - DISCONNECT ELECTRONIC CONTROL MODULE CONNECTORS.
  - WITH A FUSED JUMPER WIRE, JUMPER THE "+" BATTERY TERMINAL TO PIN "G" OF THE DATA LINK CONNECTOR.
  - BACKPROBE ELECTRONIC CONTROL MODULE HARNESS CONNECTOR "D16" WITH TEST LIGHT CONNECTED TO GROUND. IS TEST LIGHT "ON"?

NO — REPAIR OPEN CIRCUIT ON BLUE "INJECTOR CONTROL CIRCUIT" WIRE, BETWEEN INJECTOR HARNESS CONNECTOR AND ELECTRONIC CONTROL MODULE TERMINAL "D16".

YES —

- 16
- REMOVE FUSED JUMPER WIRE FROM DATA LINK CONNECTOR.
  - USING A DIGITAL MULTIMETER J 39689, CHECK THE RESISTANCE BETWEEN THE ELECTRONIC CONTROL MODULE HARNESS CONNECTOR TERMINALS "D9" AND "D10". RESISTANCE SHOULD BE LESS THAN 1 OHM. IS IT?

YES — FAULTY CONNECTIONS, OR FAULTY ELECTRONIC CONTROL MODULE.

NO —

REPAIR OPEN CIRCUIT IN THE WIRE LOOP, BETWEEN ELECTRONIC CONTROL MODULE HARNESS CONNECTOR TERMINAL "D9" TO "D10".

2-8-93  
 NS 15803

## 2-48 ENGINE MANAGEMENT SYSTEMS 1.7L THROTTLE BODY INJECTION

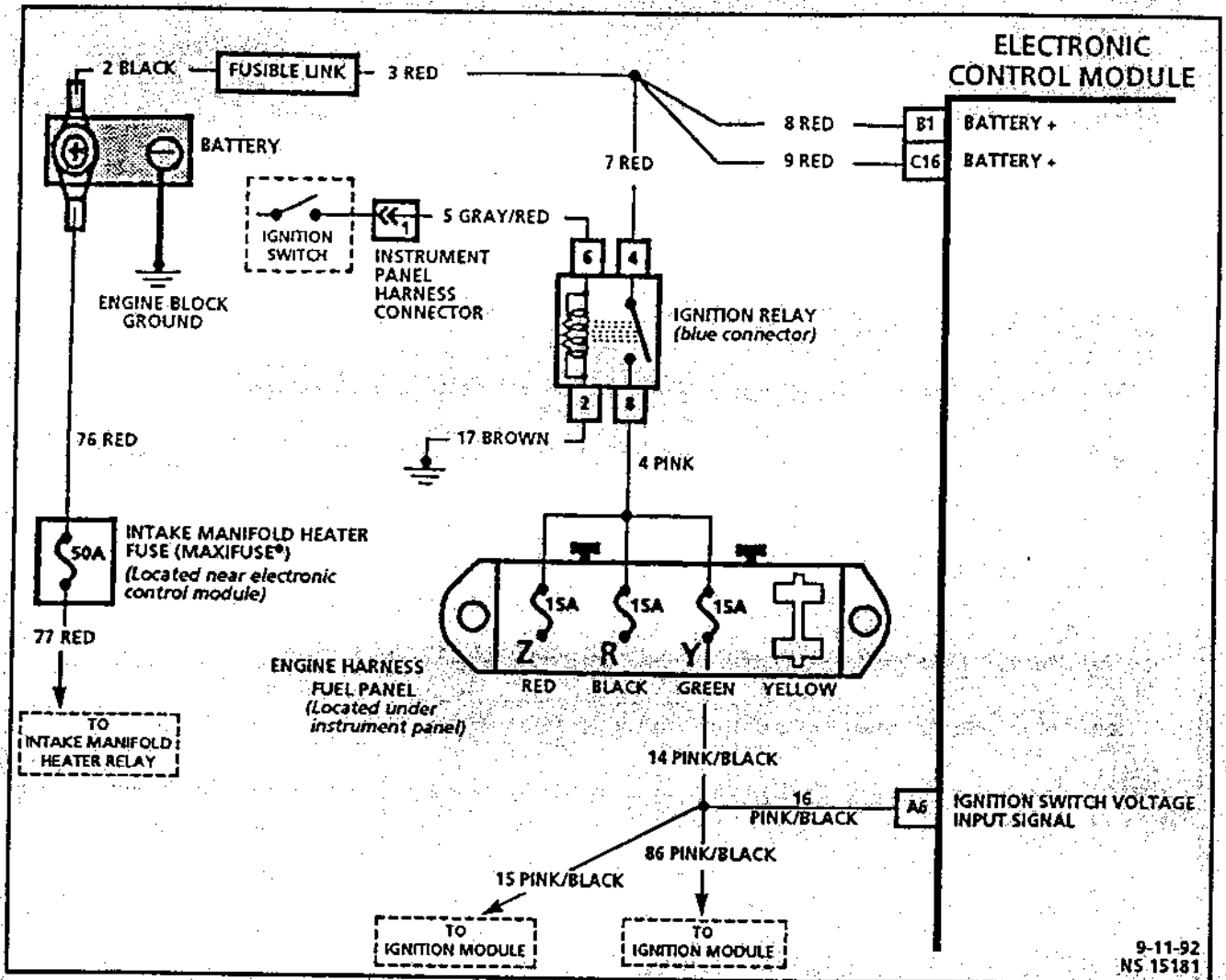

### CHART A-4

(Page 1 of 2)

## IGNITION RELAY AND POWER CIRCUITS CHECK 1.7L THROTTLE BODY INJECTION NIVA

### Circuit Description:

When the ignition switch is turned "ON," it activates the ignition relay and supplies voltage to the electronic control module. The electronic control module will operate as long as voltage is applied to electronic control module terminal "A6" ignition switch voltage input signal during cranking or running. The electronic control module terminals "B1" and "C16" receive power directly from the battery, through a fusible link.

**Test Description:** Number(s) below refer to circled number(s) on the diagnostic chart.

1. Power is supplied from the battery through a fusible link, directly to both terminals "B1" and "C16" of the electronic control module.
2. If the ignition relay and the wiring that supplies power to terminal "A6" are okay, the testlight should light.
3. Battery voltage should be available at the ignition relay's blue connector, terminal "4" and "6".

(These are gray/red wire and the Red wire terminals.) If power is available at both terminals, the testlight should light when touched to each of the two relay terminals.

### Diagnostic Aids:

The intake manifold heater relay is the same as the ignition relay. If the ignition relay fails the intake manifold heater relay can be used to operate the vehicle until a replacement relay can be obtained.

**CHART A-4**  
 (Page 1 of 2)  
**IGNITION RELAY AND POWER**  
**CIRCUITS CHECK**  
**1.7L THROTTLE BODY**  
**INJECTION NIVA**

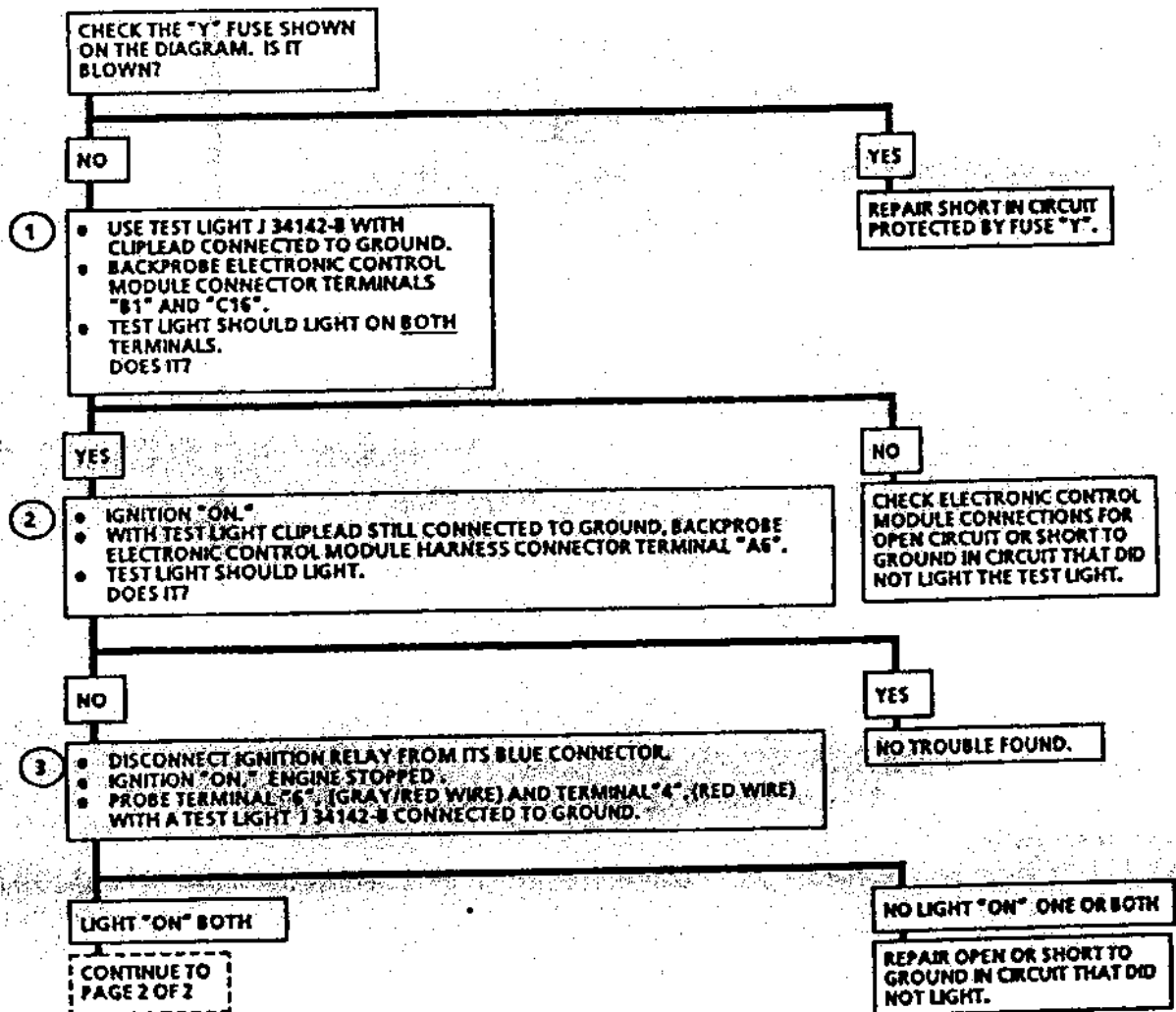

9-22-92  
 NS 15802

## 2-50 ENGINE MANAGEMENT SYSTEMS 1.7L THROTTLE BODY INJECTION

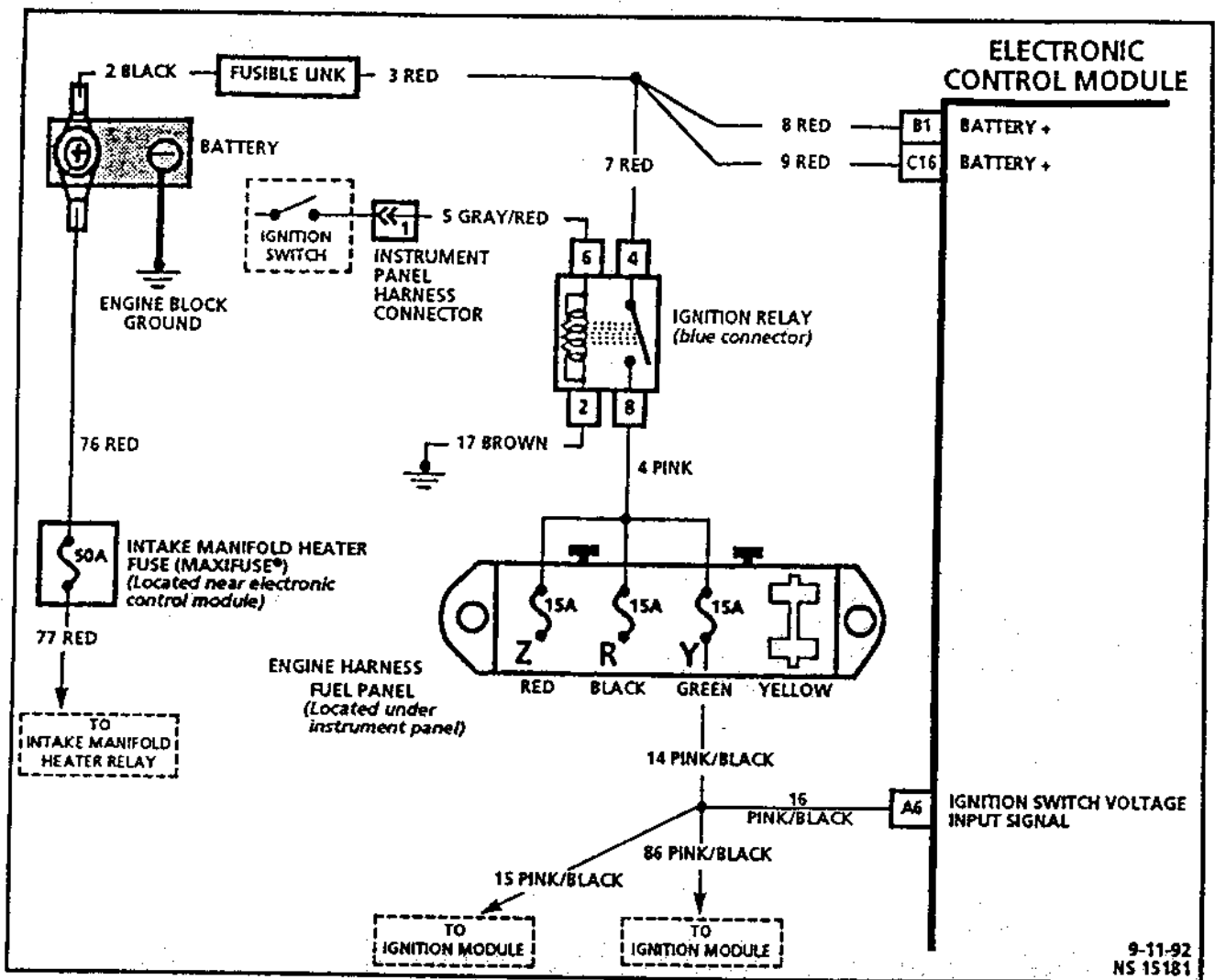

### CHART A-4

(Page 2 of 2)

### IGNITION RELAY AND POWER CIRCUITS CHECK 1.7L THROTTLE BODY INJECTION NIVA

#### Circuit Description:

When the ignition switch is turned "ON," it activates the ignition relay and supplies voltage to the electronic control module. The electronic control module will operate as long as voltage is applied to electronic control module terminal "A6" ignition switch voltage input signal during cranking or running. The electronic control module terminals "B1" and "C16" receive power directly from the battery, through a fusible link.

**Test Description:** Number(s) below refer to circled number(s) on the diagnostic chart.

- A previous test proved that power was available at the relay connector, terminal "6" (Gray/Red wire). This test will check if the Brown wire to relay terminal "2" is a good ground circuit.
- This test checks the switch portion of the relay. The Tech 1 "Scan" tool displays "system voltage" from the electronic control module's interpretation of the voltage level at terminal "A6".

- This checks the Pink wire, from the ignition relay blue connector to the fuse block.

#### Diagnostic Aids:

The intake manifold heater relay is the same as the ignition relay. If the ignition relay fails, the intake manifold heater relay can be used to operate the vehicle until a replacement relay can be obtained.

# **TURBONutter**

Lada Niva 4x4  
Service Manual  
Fuel Injection

This manual and a host of other wonderful Lada Niva documentation is available free of charge at:

<http://www.turbo-nutter.com>

You can do anything you like with this manual except sell it or otherwise make money from it.

While I can't stop you sticking it on your own website I would much prefer you linked to its original location on turbo-nutter.com

You use the information contained with this manual at you own risk. If you're not sure how to do something either don't do it or ask someone who knows about such things. The font of all Lada knowledge can be found at:

<http://www.lada.co.uk/forum>

For Lada parts, advice and general all round Lada wonderfulness these blokes aren't bad:

Lada UK Ltd  
Askew Rigg  
Troutbeck  
Penrith, Cumbria  
CA11 0SZ  
United Kingdom

T: +44 (0) 17 6877 9794  
F: +44 (0) 17 6877 9197  
E: [alan@lada.co.uk](mailto:alan@lada.co.uk)  
W: <http://www.lada.co.uk>

Lada Parts Australia P/L  
42 Aerodrome Road  
Caboolture  
Queensland  
4510  
Australia

T: +61 7 5495 5100  
F: +61 7 5495 5152  
E: [andy@ladaparts.com](mailto:andy@ladaparts.com)  
W: <http://www.ladaparts.com>

**CHART A-4**

(Page 2 of 2)  
**IGNITION RELAY AND  
 POWER CIRCUITS CHECK  
 1.7L THROTTLE BODY  
 INJECTION NIVA**

FROM PAGE  
 1 OF 2

4 • CONNECT TEST LIGHT BETWEEN TERMINALS "2" AND "6" OF IGNITION RELAY BLUE HARNESS CONNECTOR.

LIGHT "ON"

LIGHT "OFF"

5 • USING CONNECTOR TERMINAL TEST ADAPTER KIT, JUMPER TERMINALS "4" (RED WIRE) AND TERMINAL "8" (PINK WIRE) TOGETHER USING A FUSED JUMPER WIRE.  
 • CONNECT TECH 1 "SCAN" TOOL. SELECT "F0: DATA LIST."  
 • TECH 1 "SCAN" TOOL SHOULD DISPLAY "SYSTEM VOLTAGE" NEAR BATTERY VOLTAGE. DOES IT?

REPAIR OPEN CIRCUIT IN BROWN WIRE #17 TO RELAY CONNECTOR TERMINAL "2".

NO

YES

IS FUSE "Y" OK?

FAULTY CONNECTION OR FAULTY RELAY

YES

NO

• WITH RELAY HARNESS CONNECTOR TERMINALS "4" AND "8" STILL JUMPERED, REMOVE FUSE "Y". CONNECT TEST LIGHT FROM GROUND TO PINK WIRE TERMINAL OF FUSE "Y" HARNESS CONNECTOR. TEST LIGHT SHOULD LIGHT. DOES IT?

FAULTY FUSE "Y" OR SHORT TO GROUND ON CIRCUIT 14/15/16/86 PINK/BLACK WIRE.

YES

NO

6 FAULTY CONNECTION OR OPEN CIRCUIT 14/15/16/86 PINK/BLACK WIRE OR FAULTY ELECTRONIC CONTROL MODULE.

FAULTY CONNECTION OR OPEN PINK WIRE BETWEEN RELAY HARNESS CONNECTOR TERMINAL "8" AND FUSE "Y".



## 2-52 ENGINE MANAGEMENT SYSTEMS 1.7L THROTTLE BODY INJECTION

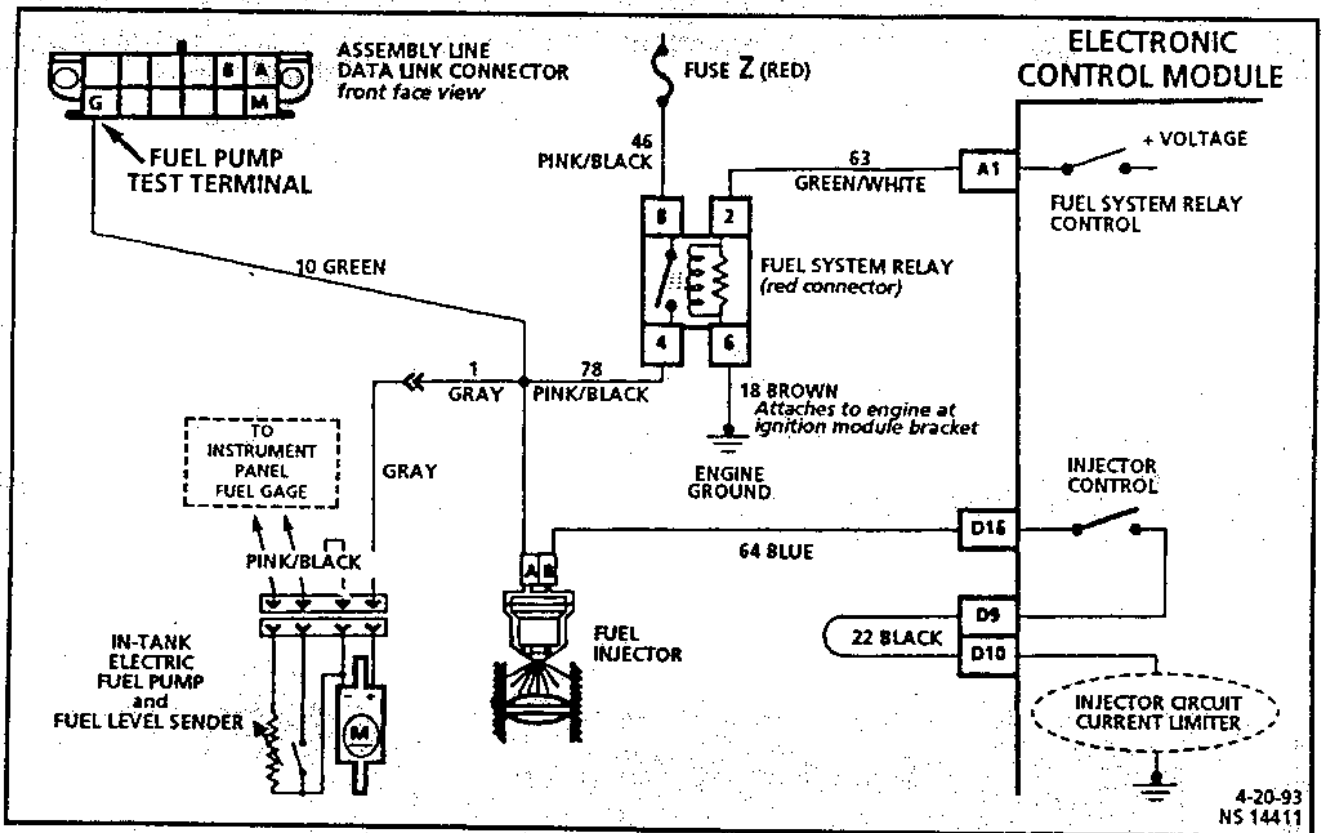

**CHART A-5**  
**FUEL SYSTEM ELECTRICAL CIRCUIT CHECK**  
**1.7L THROTTLE BODY INJECTION NIVA**

### Circuit Description:

When the ignition switch is turned "ON," the electronic control module will activate the fuel pump relay and run the in-tank fuel pump. The fuel pump will operate as long as the engine is cranking or running, and the electronic control module is receiving ignition reference pulses.

If there are no reference pulses, the electronic control module will shut "OFF" the fuel pump within 2 seconds after ignition "ON."

**Test Description:** Number(s) below refer to circled number(s) on the diagnostic chart.

1. The fuel system relay as described above can be energized by turning the ignition key to the "ON" position, after it has been "OFF" for at least 15 seconds. The fuel pump should run for 2 seconds and then turn "OFF" as described above. To reenergize the pump turn the key to the "OFF" position for 10 seconds, then turn it to the "ON" position again.

### CHART A-5 FUEL SYSTEM ELECTRICAL CIRCUIT CHECK 1.7L THROTTLE BODY INJECTION NIVA

- ①
- IGNITION MUST BE "OFF" FOR AT LEAST 15 SECONDS.
  - ENABLE FUEL SYSTEM BY TURNING IGNITION KEY TO "ON" POSITION.
  - LISTEN FOR RUNNING FUEL PUMP AT REAR OF VEHICLE.
  - FUEL PUMP SHOULD RUN FOR 2 SECONDS AFTER IGNITION "ON." DOES IT?

NO

- DISCONNECT FUEL SYSTEM RELAY.
- IGNITION "ON," ENGINE NOT RUNNING.
- PROBE RELAY HARNESS CONNECTOR TERMINAL "8" WITH A TEST LIGHT J 34142-8 CONNECTED TO GROUND.

LIGHT "ON"

CONNECT A TEST LIGHT BETWEEN HARNESS CONNECTOR TERMINALS "6" AND "8"

LIGHT "ON"

- ①
- CONNECT TEST LIGHT BETWEEN TERMINAL "2" AND GROUND.
  - ENERGIZE THE FUEL SYSTEM RELAY AS DESCRIBED IN STEP ① ABOVE.
  - TEST LIGHT SHOULD BE "ON" FOR 2 SECONDS.

LIGHT "ON"

- ①
- IGNITION "ON."
  - RECONNECT FUEL SYSTEM RELAY.
  - BACKPROBE RELAY TO CONNECT TEST LIGHT BETWEEN TERMINAL "4" AND GROUND.
  - ENERGIZE THE FUEL SYSTEM RELAY AS DESCRIBED IN STEP ① ABOVE.
  - TEST LIGHT SHOULD BE "ON" FOR 2 SECONDS.

LIGHT "ON"

- ①
- CONNECT TEST LIGHT BETWEEN FUEL PUMP TEST TERMINAL AND GROUND.
  - ENERGIZE THE FUEL SYSTEM RELAY AS DESCRIBED IN STEP ① ABOVE.
  - TEST LIGHT SHOULD BE "ON" FOR 2 SECONDS.

LIGHT "ON"

FAULTY CONNECTION  
OR  
OPEN CIRCUIT 1 GRAY WIRE  
OR  
FAULTY FUEL PUMP  
OR  
FAULTY FUEL PUMP GROUND

YES

FUEL SYSTEM RELAY CIRCUIT ELECTRICAL CHECK OK. SEE CHART A-7 FOR FUEL SYSTEM PRESSURE CHECK.

LIGHT "OFF"

FAULTY CONNECTION OR REPAIR OPEN IN CIRCUIT 45 PINK/BLACK WIRE FROM RELAY TERMINAL "8" TO FUSE "2". IF FUSE "2" IS BLOWN REPAIR SHORT TO GROUND IN FUEL PUMP CIRCUIT.

LIGHT "OFF"

FAULTY CONNECTION OR REPAIR OPEN GROUND CIRCUIT 18 BROWN WIRE AND BETWEEN FUEL PUMP AND ENGINE BLOCK GROUND RELAY TERMINAL "6".

LIGHT "OFF"

FAULTY CONNECTION OR CHECK FOR OPEN OR SHORT TO GROUND IN CIRCUIT 63 GREEN/WHITE WIRE FROM RELAY TERMINAL "2" TO ELECTRONIC CONTROL MODULE TERMINAL "A1". IF OK, IT'S A FAULTY ELECTRONIC CONTROL MODULE.

LIGHT "OFF"

FAULTY CONNECTION OR FAULTY FUEL SYSTEM RELAY.

LIGHT "OFF"

FAULTY CONNECTION  
OR  
OPEN CIRCUIT 10 GREEN WIRE  
OR  
OPEN CIRCUIT 78 PINK/GREEN WIRE

## 2-54 ENGINE MANAGEMENT SYSTEMS 1.7L THROTTLE BODY INJECTION

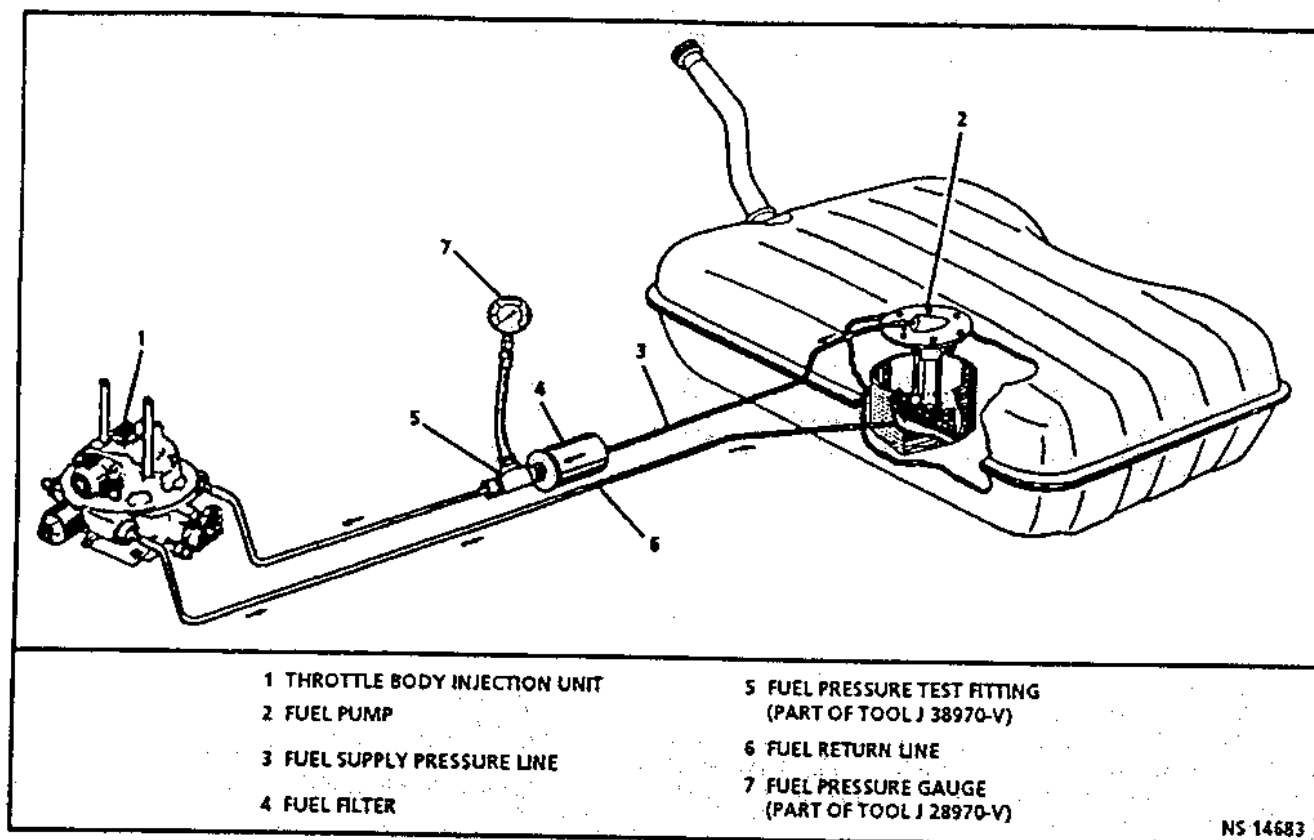

### CHART A-7

(Page 1 of 2)

### FUEL SYSTEM DIAGNOSIS 1.7L THROTTLE BODY INJECTION NIVA

#### Circuit Description:

When the ignition switch is turned "ON," the electronic control module will turn "ON" the fuel pump. It will remain "ON" as long as the engine is cranking or running, and the electronic control module is receiving crankshaft position pulses. If there are no reference pulses, the electronic control module will shut "OFF" the fuel pump within 2 seconds after key "ON."

The pump will deliver fuel to the throttle body injection unit, where the system pressure is controlled between 190 kPa (27.6 psi, 1.9 bar) and 210 kPa (30.5 psi, 2.1 bar). Excess fuel is then returned to the fuel tank.

The fuel pump test terminal (assembly line data link terminal "G") is located above and to the right of the driver's kick panel, above the electronic control module. When the engine is not running and the ignition switch is "OFF," the pump can be turned "ON" by applying battery voltage to the test terminal.

**Test Description:** Number(s) below refer to circled number(s) on the diagnostic chart.

1. Checks for proper fuel pressure and system operation. By turning the ignition key to the "ON" position you will be able to energize the fuel system for 2 seconds at a time.
2. This step checks for leaks or loose connections between the fuel pressure test fitting and the throttle body injection unit. This step will also determine if the pressure regulator is operating properly.
3. This portion ensures no leaks or loose connections are present between the fuel pump and the fuel pres-

sure test fitting. This step will also determine if the fuel pump is operating properly.

#### Diagnostic Aids:

Improper fuel system pressure can result in one of the following symptoms:

- Cranks, but will not run.
- Cuts out, may feel like ignition problem.
- Poor fuel economy, loss of power.
- Hesitation.

Have an assistant listen for fuel pump at rear of vehicle, pump may not be audible inside vehicle.

**CHART A-7**  
(Page 1 of 2)  
**FUEL SYSTEM DIAGNOSIS**  
**1.7L THROTTLE BODY INJECTION NIVA**

**1**

- FUEL TANK HAS SUFFICIENT FUEL AND FUEL QUALITY IS OK.
- IGNITION "OFF," REMOVE FUEL TANK FILLER CAP TO RELIEVE ANY RESIDUAL TANK PRESSURE.
- DISCONNECT 4-TERMINAL ELECTRICAL CONNECTOR AT FUEL PUMP. (CONNECTOR ACCESS PANEL IS LOCATED IN FLOOR PAN DIRECTLY ABOVE FUEL TANK.)
- START ENGINE AND IDLE UNTIL ENGINE STALLS. ENGAGE STARTER FOR 3 SECONDS TO RELIEVE ANY REMAINING PRESSURE.
- DISCONNECT FUEL SUPPLY PRESSURE PIPE FROM FUEL FILTER "OUTLET" FITTING. INSTALL FUEL PRESSURE TEST FITTING TOOL J 38970-V BETWEEN FUEL FILTER OUTLET FITTING AND FUEL PIPE. (SEE FACING PAGE ILLUSTRATION.)
- INSTALL PRESSURE GAUGE J 38970-V ONTO FUEL PRESSURE TEST FITTING.
- IGNITION "OFF" FOR AT LEAST 15 SECONDS.
- OBSERVE FUEL PRESSURE AS IGNITION IS TURNED TO THE "ON" POSITION. THIS WILL CAUSE THE FUEL SYSTEM RELAY TO TURN "ON" FOR 2 SECONDS, THEN "OFF." DURING THE 2 SECONDS OF "ON" TIME THE FUEL PRESSURE SHOULD BE BETWEEN 190 kPa (27.6 psi, 1.9 bar) AND 210 kPa (30 psi, 2.1 bar). IS IT?

**YES** → **2** AFTER PUMP STOPS RUNNING, PRESSURE MAY DECREASE SLIGHTLY, THEN SHOULD HOLD STEADY WITH NO FURTHER DROP IN PRESSURE. (IF ENGINE IS WARM, A SLOW GRADUAL INCREASE IN PRESSURE IS NORMAL.) WHAT DOES PRESSURE DO?

**NO** → GO TO CHART A-7 PAGE 2 OF 2.

**PRESSURE CONTINUES TO DROP** →

**PRESSURE HOLDS** → **NO TROUBLE FOUND**

- IGNITION "OFF" FOR AT LEAST 15 SECONDS.
- AGAIN TURN THE IGNITION KEY "ON" TO ENERGIZE FUEL PUMP. IMMEDIATELY AFTER PUMP STOPS RUNNING, PINCH COMPLETELY SHUT A RUBBER SECTION OF FUEL HOSE BETWEEN FUEL PRESSURE TEST FITTING AND THROTTLE BODY INJECTION UNIT. DOES FUEL PRESSURE STABILIZE AND STOP DROPPING?

**NO** → **3**

**YES** →

- CHECK FOR LEAKS OR LOOSE CONNECTIONS BETWEEN THE FUEL PRESSURE TEST FITTING AND THE THROTTLE BODY INJECTION UNIT. MAKE THE SAME CHECK BETWEEN THE THROTTLE BODY INJECTION UNIT AND THE FUEL TANK.
- IF NO PROBLEMS ARE FOUND, REPLACE FUEL PRESSURE REGULATOR ON THE THROTTLE BODY INJECTION UNIT.

**NO** →

- GO THROUGH STEP 2, AGAIN MAKING SURE THERE ARE NO LEAKS OR LOOSE CONNECTIONS AS SPECIFIED ABOVE.

**YES** →

- CHECK FOR LEAKS OR LOOSE CONNECTIONS BETWEEN THE FUEL TANK AND THE FUEL PRESSURE TEST FITTING (THE SUPPLY LINE INCLUDING FUEL FILTER).
- IF NO PROBLEMS ARE FOUND REPLACE FUEL PUMP.

4-27-93  
NS 14413

## 2-56 ENGINE MANAGEMENT SYSTEMS 1.7L THROTTLE BODY INJECTION

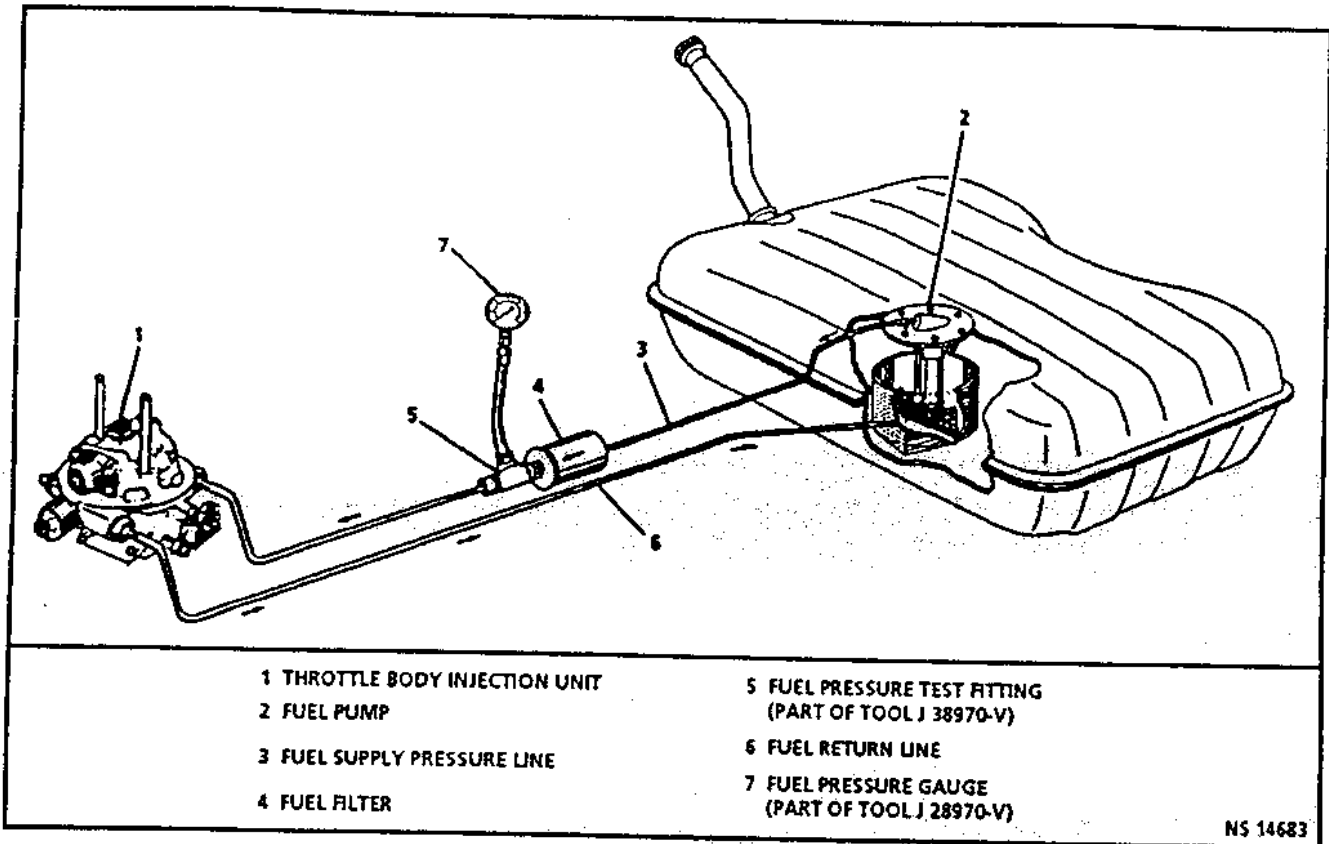

### CHART A-7

(Page 2 of 2)

### FUEL SYSTEM DIAGNOSIS 1.7L THROTTLE BODY INJECTION NIVA

**Test Description:** Number(s) below refer to circled number(s) on the diagnostic chart.

4. Fuel pressure less than 190 kPa (27.6 psi, 1.9 bar) falls into two areas:
  - Amount of fuel to injector is OK, but the pressure is less than 190 kPa (27.6 psi, 1.9 bar). Low fuel pressure can cause poor overall performance.
  - Restricted flow causing pressure drop. Normally, a vehicle with a fuel pressure of less than 190 kPa (27.6 psi, 1.9 bar) at idle will not be driveable. However, if the pressure drop occurs only while driving, the engine will surge, then stop, as pressure begins to drop rapidly.

5. Turning the fuel pump "ON" and restricting fuel flow at the fuel pressure gage will determine if the fuel pump can supply enough fuel pressure to the injector to operate properly, above 190 kPa (27.6 psi, 1.9 bar).

**NOTICE:** Do not restrict the fuel return line, this may damage the fuel pressure regulator.

6. This test determines if the high fuel pressure is due to a restricted fuel return line, or a throttle body pressure regulator problem. Apply battery voltage to the fuel pump test connector only long enough to get an accurate fuel pressure reading.

**CHART A-7**  
(Page 2 of 2)  
**FUEL SYSTEM DIAGNOSIS**  
**1.7L THROTTLE BODY**  
**INJECTION NIVA**

FROM CHART A-7  
(PAGE 1 OF 2)

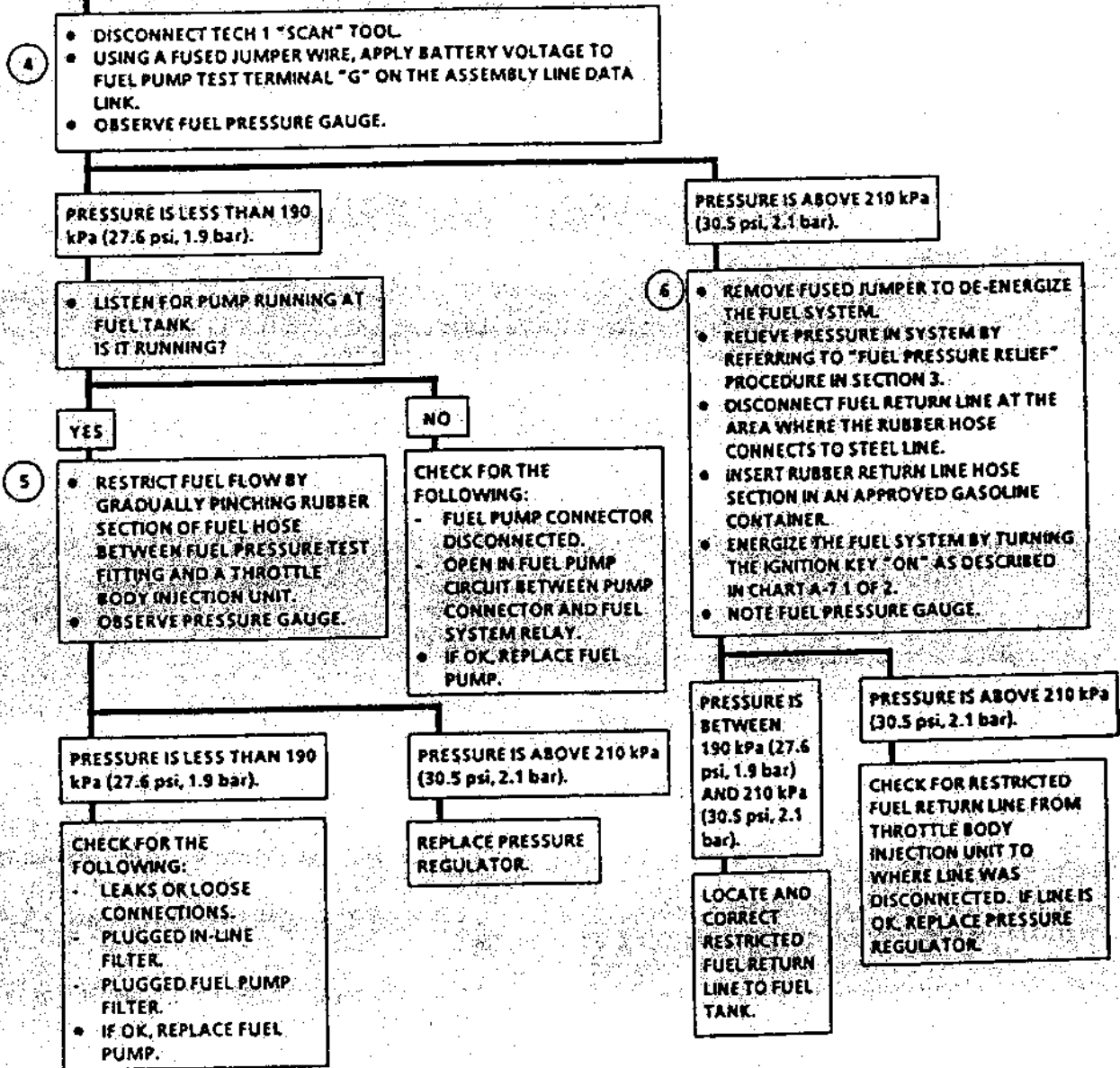

## 2-58 ENGINE MANAGEMENT SYSTEMS 1.7L THROTTLE BODY INJECTION

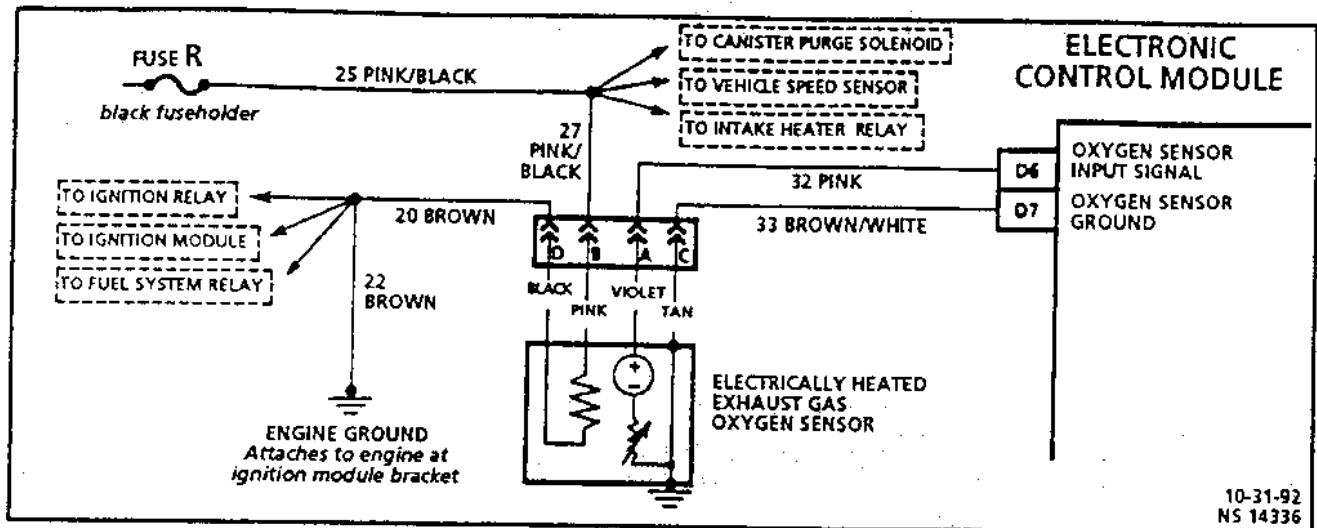

### CODE 13 NO OXYGEN SENSOR SIGNAL 1.7L THROTTLE BODY INJECTION NIVA

#### Circuit Description:

The electronic control module applies a reference voltage of approximately 450 millivolts between terminals "D7" and "D6". The oxygen sensor varies the voltage within a range of about 1 volt if the exhaust is rich, and down through about 10 millivolt if exhaust is lean. Code 13 is set when the voltage does not vary on Circuit 32 within a pre-determined amount of time.

The sensor is like an open circuit and produces no voltage when it is below 315°C. An open sensor circuit, or a cold sensor causes "Open Loop" operation.

The heater circuit of the oxygen sensor is turned "ON" by the ignition relay when the engine is running.

**Test Description:** Number(s) below refer to circled number(s) on the diagnostic chart.

- Code 13 will set:
  - Engine has been running longer than 40 seconds.
  - Engine coolant temperature greater than 77°C.
  - Throttle position sensor signal above 6% (about 0.3 volt above closed throttle voltage).
  - Oxygen sensor signal voltage steady between 350 and 550 millivolts for 3 seconds.

If the conditions for a Code 13 exist, the system will not go into "Closed Loop."

- This test checks the oxygen sensor's heating element. The heating element resistance should be 3.5 ohms at 20°C or 13.2 ohms at 595°C. At room temperature (20°C) the heater resistance should be 3.5–4.5Ω, normally it should be about 3.8Ω.
- This will determine if the sensor is at fault.
- For this test use only a high impedance digital voltmeter. This test checks the continuity of Circuit 32 Pink wire and Circuit 33 Brown/White wire. If Circuit 33 Brown/White wire is open, the electronic control module voltage on Circuit 32 Pink wire will be over 600 mV.

- If the air conditioning fuse was open, check the air conditioning fuse circuits or generator circuits for shorts.

#### Diagnostic Aids:

If the oxygen sensor heaters are not operating properly, system may go into "Open Loop" after extended idle.

Normal voltage varies between 10 mV to 1000 mV (.01 and 1.0 volt), while in "Closed Loop." Code 13 sets in one minute if voltage remains between 350 and 550 millivolt, however, the system will go "Open Loop" in about 15 seconds.

Refer to "Intermittents" in "Symptoms," Section "2.9B".

An oxygen supply inside the oxygen sensor is necessary for proper oxygen sensor operation. This supply of oxygen is supplied through the oxygen sensor wires. All oxygen sensor wires and connections should be inspected for breaks or contamination that could prevent reference oxygen from reaching the oxygen sensor.

**CODE 13**  
**NO OXYGEN SENSOR**  
**SIGNAL**  
**1.7L THROTTLE BODY**  
**INJECTION NIVA**

1 ENGINE AT NORMAL OPERATING TEMPERATURE (85°C-95°C).  
 • RUN ENGINE ABOVE 1200 REVOLUTIONS PER MINUTE FOR TWO MINUTES.  
 DOES TECH 1 "SCAN" TOOL INDICATE "CLOSED LOOP"?

NO

YES

• IGNITION "OFF."  
 • DISCONNECT OXYGEN SENSOR HARNESS CONNECTOR.  
 • CONNECT TEST LIGHT J 34142-8 BETWEEN HARNESS TERMINALS "B" AND "D".  
 • IGNITION "ON."  
 IS TEST LIGHT "ON"?

CODE 13 IS INTERMITTENT. IF NO ADDITIONAL CODES WERE STORED, REFER TO "DIAGNOSTIC AIDS."

YES

NO

2 • USING DIGITAL VOLT OHM AMP MULTIMETER J 39689 MEASURE RESISTANCE BETWEEN OXYGEN SENSOR TERMINALS "B" AND "D".  
 • IS RESISTANCE BETWEEN 3.5 OHMS AND 13.2 OHMS?

• CONNECT TEST LIGHT TO HARNESS TERMINAL "B" AND GROUND.  
 • IS TEST LIGHT "ON"?

YES

NO

NO

YES

3 • USING CONNECTOR TERMINAL TEST ADAPTER KIT J 35616 TO JUMPER HARNESS CIRCUIT 32 PINK TO GROUND.  
 • TECH 1 SHOULD DISPLAY OXYGEN VOLTAGE BELOW .2 VOLT (200 mV) WITH ENGINE RUNNING. DOES IT?

FAULTY OXYGEN SENSOR

5 FAULTY CONNECTION OR FAULTY FUSE "R" OPEN CIRCUIT 25 PINK/BLACK OR 27 PINK/BLACK OR SHORT CIRCUIT TO GROUND IN CIRCUIT 25, 26, 27, 29, 82 PINK/BLACK.

FAULTY CONNECTION OR OPEN CIRCUIT 26 BROWN OR FAULTY ENGINE BLOCK GROUND.

NO

YES

4 • REMOVE JUMPER.  
 • IGNITION "ON," ENGINE "OFF."  
 • USING DIGITAL VOLT OHM AMP MULTIMETER J 39689 CHECK VOLTAGE OF CIRCUIT 32 PINK AT OXYGEN SENSOR.

FAULTY OXYGEN SENSOR CONNECTION OR FAULTY OXYGEN SENSOR.

3-.6 VOLT (300 - 600 mV)

OVER .6 VOLT (600 mV)

LESS THAN .3 VOLT (300 mV)

FAULTY ELECTRONIC CONTROL MODULE

FAULTY CONNECTION OR OPEN CIRCUIT 33 BROWN/WHITE WIRE OR FAULTY ELECTRONIC CONTROL MODULE.

FAULTY ELECTRONIC CONTROL MODULE CONNECTION OR OPEN CIRCUIT 32 PINK/WIRE OR FAULTY ELECTRONIC CONTROL MODULE.

"AFTER REPAIRS." START ENGINES, CLEAR CODES AND CONFIRM NO "CHECK ENGINE" LIGHT.



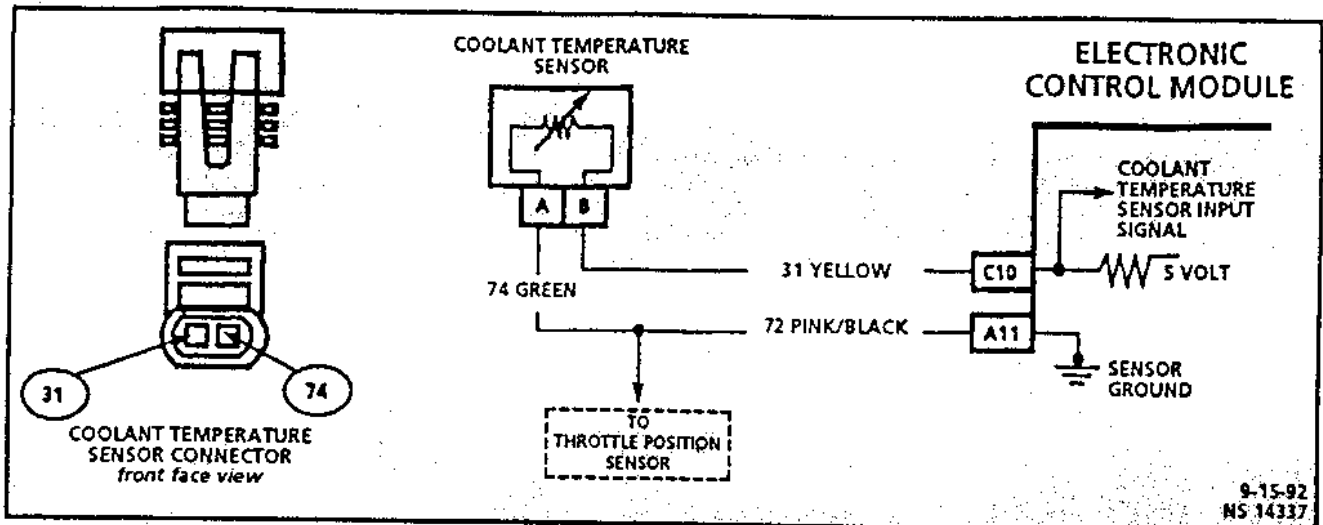

9-15-92  
MS 14337

## CODE 14

### COOLANT TEMPERATURE (SIGNAL VOLTAGE TOO LOW)

#### 1.7L THROTTLE BODY INJECTION NIVA

#### Circuit Description:

The coolant temperature sensor is a thermistor that controls the signal voltage to the electronic control module. The electronic control module applies about 5 volts on the Yellow wire from electronic control module terminal "C10" to the coolant temperature sensor, and "looks" at the voltage drop. When the engine coolant is cold the sensor (thermistor) resistance is high, therefore the electronic control module will "see" high signal voltage.

As the engine warms, the coolant sensor (thermistor) resistance becomes less, and the electronic control module sees a lower signal voltage. At normal engine operating temperature (85°C-95°C) the voltage will measure about 1.5 to 2.0 volts.

**Test Description:** Number(s) below refer to circled number(s) on the diagnostic chart.

1. Code 14 will set if:
  - Engine has been running longer than 2 seconds.
  - AND
  - Coolant temperature sensor input signal voltage indicates engine coolant temperature is above 135°C.
2. This test determines if the Circuit 31 Yellow wire from the coolant temperature sensor to electronic control module terminal "C10" is shorted to ground (low volts/resistance) which will set a Code 14.

#### Diagnostic Aids:

The Tech 1 "Scan" tool displays engine temperature in degrees Celsius. After the engine is started, the temperature should rise steadily to about 85-95°C then stabilize when the thermostat opens. Check terminals at the sensor for a good connection.

Refer to "Intermittents" in "Symptoms," Section "2.9B".

**CODE 14**  
**COOLANT TEMPERATURE**  
**(SIGNAL VOLTAGE TOO LOW)**  
**1.7L THROTTLE BODY INJECTION NIVA**

1

- IGNITION "ON," ENGINE NOT RUNNING.
- CONNECT TECH 1.
- SELECT "F0: DATA LIST."
- DOES TECH 1 DISPLAY COOLANT TEMPERATURE OF 130°C OR HIGHER?

YES

NO

2

- DISCONNECT COOLANT TEMPERATURE SENSOR.
- TECH 1 SHOULD DISPLAY COOLANT TEMPERATURE BELOW -30°C. DOES IT?

CODE 14 IS INTERMITTENT. IF NO ADDITIONAL CODES WERE STORED, REFER TO "DIAGNOSTIC AIDS" ON FACING PAGE.

YES

NO

REPLACE COOLANT TEMPERATURE SENSOR.

CIRCUIT 31 YELLOW WIRE FROM THE COOLANT TEMPERATURE SENSOR TO ELECTRONIC CONTROL MODULE TERMINAL "C10" IS SHORTED TO GROUND OR  
 CIRCUIT 31 YELLOW WIRE FROM THE COOLANT TEMPERATURE SENSOR TO ELECTRONIC CONTROL MODULE TERMINAL "C10" IS SHORTED TO COOLANT TEMPERATURE SENSOR AND THROTTLE POSITION SENSOR GROUND CIRCUIT, CIRCUIT 72 PINK/BLACK OR CIRCUIT 74 GREEN WIRE FROM THE COOLANT TEMPERATURE SENSOR AND THROTTLE POSITION SENSOR TO ELECTRONIC CONTROL MODULE TERMINAL "A11" OR FAULTY ELECTRONIC CONTROL MODULE.

**DIAGNOSTIC AID**

| COOLANT TEMPERATURE SENSOR                      |        |
|---|--------|
| TEMPERATURE VS. RESISTANCE VALUES (APPROXIMATE) |        |
| °C  | OHMS   |
| 100   | 177    |
| 90  | 241    |
| 80  | 332    |
| 70  | 467    |
| 60  | 667    |
| 50  | 973    |
| 45  | 1188   |
| 40  | 1459   |
| 35  | 1802   |
| 30  | 2238   |
| 25  | 2796   |
| 20  | 3520   |
| 15  | 4450   |
| 10  | 5670   |
| 5   | 7280   |
| 0   | 9420   |
| -5  | 12300  |
| -10   | 16180  |
| -15   | 21450  |
| -20   | 28680  |
| -30   | 52700  |
| -40   | 100700 |

"AFTER REPAIRS," START ENGINE, CLEAR CODES AND CONFIRM NO "CHECK ENGINE" LIGHT.

5-27-92  
 NS 14338

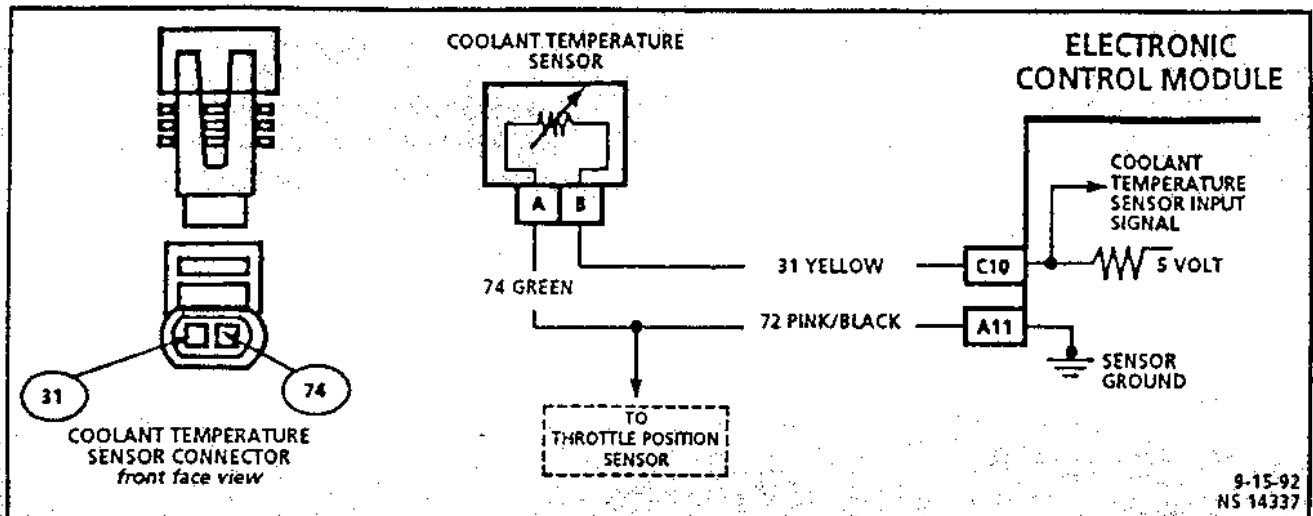

## CODE 15

### COOLANT TEMPERATURE (SIGNAL VOLTAGE TOO HIGH)

#### 1.7L THROTTLE BODY INJECTION NIVA

#### Circuit Description:

The coolant temperature sensor is a thermistor that controls the signal voltage to the electronic control module. The electronic control module applies about 5 volts on Circuit 31 Yellow wire from the electronic control module terminal "C10" to the coolant temperature sensor, and "looks" at the voltage drop. When the engine coolant is cold the sensor (thermistor) resistance is high, therefore the electronic control module will "see" high signal voltage.

As the engine warms, the coolant sensor (thermistor) resistance becomes less, and the electronic control module sees a lower signal voltage. At normal engine operating temperature (85°C–95°C) the voltage will measure about 1.5 to 2.0 volts.

**Test Description:** Number(s) below refer to circled number(s) on the diagnostic chart.

1. Code 15 will set if:
  - Engine has been running longer than 58 seconds.
  - AND
  - Coolant temperature sensor signal voltage indicates engine coolant temperature less than -37°C.
2. This test simulates a Code 14 - coolant temperature sensor (high temperature - low voltage/resistance indicated). If the electronic control module receives the low voltage/resistance signal (high temperature), and the Tech 1 "Scan" tool displays 130°C or above, the electronic control module and the coolant temperature sensor circuits are OK.
3. This tests for an open in the Circuit 31 Yellow wire from the coolant temperature sensor to electronic control module terminal "C10". When the Circuit 31 Yellow wire is jumpered/shorted to a good ground—the electronic control module should "see" a low resistance/voltage—high temperature on the coolant temperature sensor circuit (electronic con-

rol module terminal "C10"). If the Tech 1 displays a high temperature when the Yellow wire is shorted to ground, then the Circuit 31 Yellow wire to electronic control module terminal "C10" and the electronic control module are OK.

Voltage between the Circuit 31 Yellow wire (coolant temperature sensor to electronic control module terminal "C10") and ground is normally 5 volts (the coolant temperature sensor connector disconnected and not jumpered/shorted to ground).

#### Diagnostic Aids:

The Tech 1 "Scan" tool reads engine coolant temperature in degrees Celsius. After the engine is started, the temperature should rise steadily to about 85-95°C, then stabilize when the thermostat opens.

If Code 21 - throttle position sensor is also set, check coolant temperature sensor and throttle position sensor ground circuit (Circuit 74 Green wire Circuit 72 Pink/Black wire) for faulty wiring or connections. Check terminals at sensor for a good connection.

Refer to "Intermittents" in "Symptoms," Section "2.9B".



## 2-64 ENGINE MANAGEMENT SYSTEMS 1.7L THROTTLE BODY INJECTION

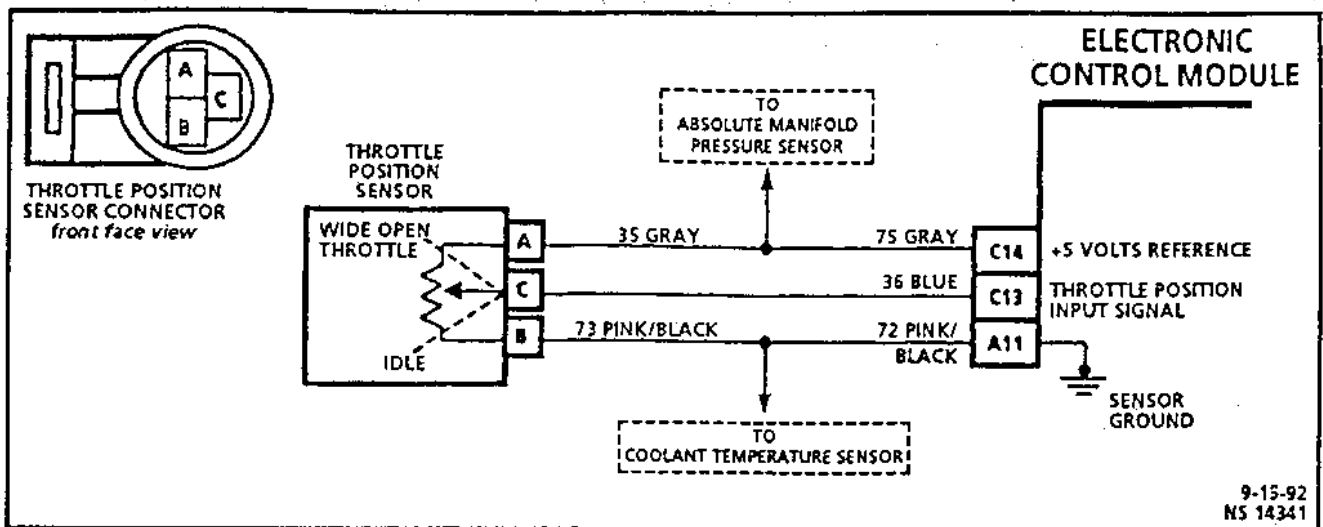

### CODE 21 THROTTLE POSITION (SIGNAL VOLTAGE TOO HIGH) 1.7L THROTTLE BODY INJECTION NIVA

#### Circuit Description:

The throttle position sensor provides a voltage signal that changes relative to the throttle blade. Throttle position sensor signal voltage varies from about 0.25 to 1.25 volts at idle to about 5 volts at wide open throttle.

The throttle position sensor signal is one of the inputs used by the electronic control module for fuel control and for most of the controlled outputs.

**Test Description:** Number(s) below refer to circled number(s) on the diagnostic chart.

- Code 21 will set if:
  - Throttle position sensor signal voltage is greater than 2.56 volts.
  - Manifold absolute pressure is less than 47 kPa.
  - Engine speed is less than or equal to 2000 revolutions per minute.
  - All conditions met for 2 seconds.
- With the throttle position sensor disconnected, the throttle position sensor signal voltage should go low if the electronic control module and wiring are OK.
- Probing coolant temperature sensor and throttle position sensor ground circuit (Circuit 72/73 Pink/Black wire from throttle position sensor connector terminal "B" to electronic control module terminal "A11") with a test light to 12 volts checks the sensor ground circuit. A faulty sensor ground can cause a Code 21.

#### Diagnostic Aids:

A Tech 1 "Scan" tool reads throttle position in volts. With ignition "ON" or at idle, throttle position sensor signal voltage should read between 0.25 to 1.25 volts with the throttle closed and increase at a steady rate as throttle is moved toward wide open throttle. An open in coolant temperature sensor and throttle position sensor ground circuit (Circuit 72/73 Pink/Black wire from throttle position sensor connector terminal "B" to electronic control module terminal "A11") will result in a Code 21.

Refer to "Intermittents" in "Symptoms," Section "2.9B".

**CODE 21**  
**THROTTLE POSITION**  
**(SIGNAL VOLTAGE TOO HIGH)**  
**1.7L THROTTLE BODY INJECTION NIVA**

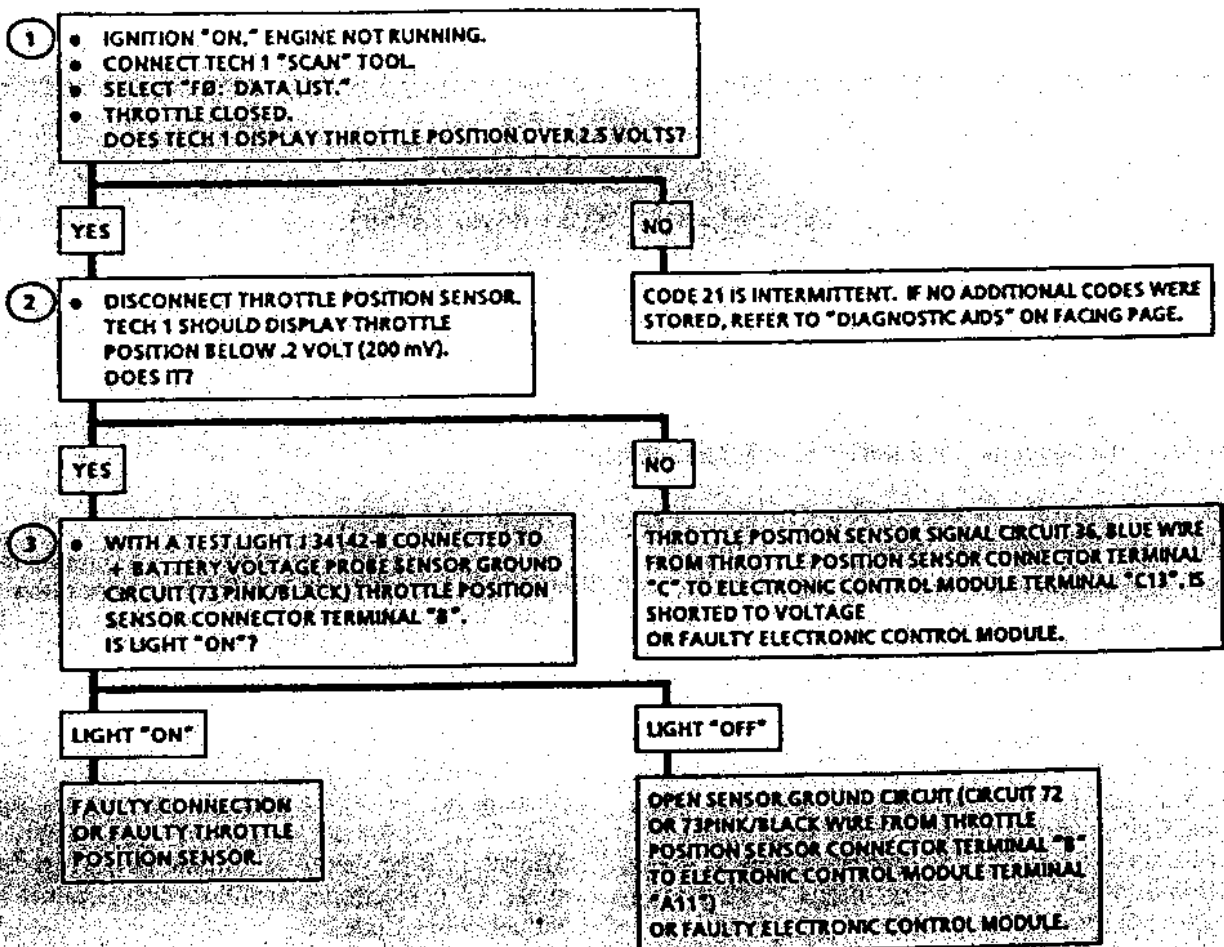

"AFTER REPAIRS," START ENGINE. CLEAR CODES AND CONFIRM NO "CHECK ENGINE" LIGHT.

5-27-92  
 NS 14342

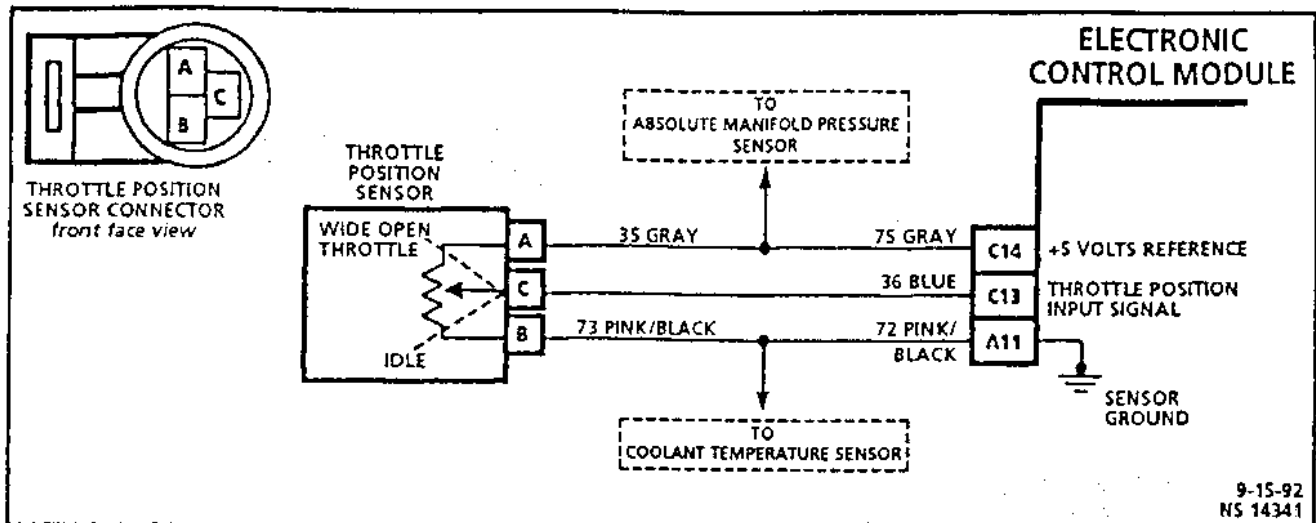

**CODE 22**  
**THROTTLE POSITION**  
**(SIGNAL VOLTAGE TOO LOW)**  
**1.7L THROTTLE BODY INJECTION NIVA**

**Circuit Description:**

The throttle position sensor provides a voltage signal that changes relative to the throttle blade. Throttle position sensor signal voltage varies from about 0.25 to 1.25 volts at idle to about 5 volts at wide open throttle.

The throttle position sensor signal is one of the inputs used by the electronic control module for fuel control and for most of the electronic control module controlled outputs.

**Test Description:** Number(s) below refer to circled number(s) on the diagnostic chart.

1. Code 22 will set if:
  - Engine has been running.
  - Throttle position sensor signal voltage is less than 0.16 volt.

The throttle position sensor has an auto zeroing feature. If the voltage reading is within the range of about 0.25 to 1.25 volts, the electronic control module will use that value as closed throttle. If the voltage reading is out of the auto zero range at closed throttle, check for a binding throttle cable or damaged linkage, if OK, continue with diagnosis.

2. This step simulates Code 21: (high voltage). If the electronic control module recognizes the high signal voltage, then the electronic control module and wiring are OK.
3. This simulates a high signal voltage to check for an open in throttle position sensor signal input circuit (Circuit 36 Blue wire from throttle position sensor terminal "C" to electronic control module terminal "C13"). The Tech 1 "Scan" tool will not read up to 12 volts, but what is important is that the electronic control module recognizes the signal on throttle position sensor signal input circuit.

**Diagnostic Aids:**

A Tech 1 "Scan" tool reads throttle position in volts. With ignition "ON" or at idle, throttle position sensor signal voltage should read between 0.25 to 1.25 volts with the throttle closed and increase at a steady rate as throttle is moved toward wide open throttle.

An open or short to ground in +5 volt reference circuit (Circuit 35/75 Gray wire from throttle position sensor terminal "A" to electronic control module terminal "C14") or throttle position sensor signal input circuit (Circuit 36 Blue wire from throttle position sensor terminal "C" to electronic control module terminal "C13") will result in a Code 22.

Refer to "Intermittents" in "Symptoms," Section "2.9B".

**CODE 22**  
**THROTTLE POSITION**  
**(SIGNAL VOLTAGE TOO LOW)**  
**1.7L THROTTLE BODY INJECTION NIVA**

①

- IGNITION "ON," ENGINE NOT RUNNING.
- CONNECT TECH 1 "SCAN" TOOL.
- SELECT "FB: DATA LIST."
- THROTTLE CLOSED.

DOES TECH 1 DISPLAY THROTTLE POSITION 0.2V (200 mV) OR BELOW?

NO → CODE 22 IS INTERMITTENT. IF NO ADDITIONAL CODES WERE STORED, REFER TO "DIAGNOSTIC AIDS" ON FACING PAGE.

YES →

②

- DISCONNECT THROTTLE POSITION SENSOR CONNECTOR.
- USING CONNECTOR TERMINAL TEST ADAPTER KIT J 35616 TO JUMPER THROTTLE POSITION SENSOR CONNECTOR TERMINALS "A" AND "C" (CIRCUIT 35/75 GRAY WIRE FROM THROTTLE POSITION SENSOR TERMINAL "A" TO ELECTRONIC CONTROL MODULE TERMINAL "C14" AND CIRCUIT 36 BLUE WIRE FROM THROTTLE POSITION SENSOR TERMINAL "C" TO ELECTRONIC CONTROL MODULE TERMINAL "C13").

TECH 1 "SCAN" TOOL SHOULD DISPLAY THROTTLE POSITION OVER 4.0V (4000 mV). DOES IT?

NO → FAULTY THROTTLE POSITION SENSOR CONNECTION OR FAULTY THROTTLE POSITION SENSOR.

YES →

③

- WITH A TEST LIGHT J 34142-B CONNECTED TO + BATTERY VOLTAGE USE CONNECTOR TERMINAL TEST ADAPTER KIT J 35616 TO PROBE THROTTLE POSITION SENSOR TERMINAL "C" (THROTTLE POSITION SENSOR INPUT SIGNAL CIRCUIT 36 BLUE). TECH 1 SHOULD DISPLAY THROTTLE POSITION OVER 4.0V (4000 mV). DOES IT?

NO → THROTTLE POSITION SENSOR INPUT SIGNAL CIRCUIT (CIRCUIT 36 BLUE WIRE FROM ELECTRONIC CONTROL MODULE TERMINAL "C13" TO THROTTLE POSITION SENSOR TERMINAL "C") IS OPEN OR SHORTED TO GROUND, OR SHORTED TO THROTTLE POSITION SENSOR GROUND CIRCUIT (CIRCUIT 72/73 PINK/BLACK WIRE) OR FAULTY ELECTRONIC CONTROL MODULE CONNECTION OR FAULTY ELECTRONIC CONTROL MODULE.

YES → 5 VOLT REFERENCE CIRCUIT (CIRCUIT 35/75 GRAY WIRE FROM ELECTRONIC CONTROL MODULE TERMINAL "C14" TO THROTTLE POSITION SENSOR TERMINAL "A") IS OPEN OR SHORTED TO GROUND OR FAULTY CONNECTION OR FAULTY ELECTRONIC CONTROL MODULE.

"AFTER REPAIRS," START ENGINE, CLEAR CODES AND CONFIRM NO "CHECK ENGINE" LIGHT.

6-2-92  
 NS 14361



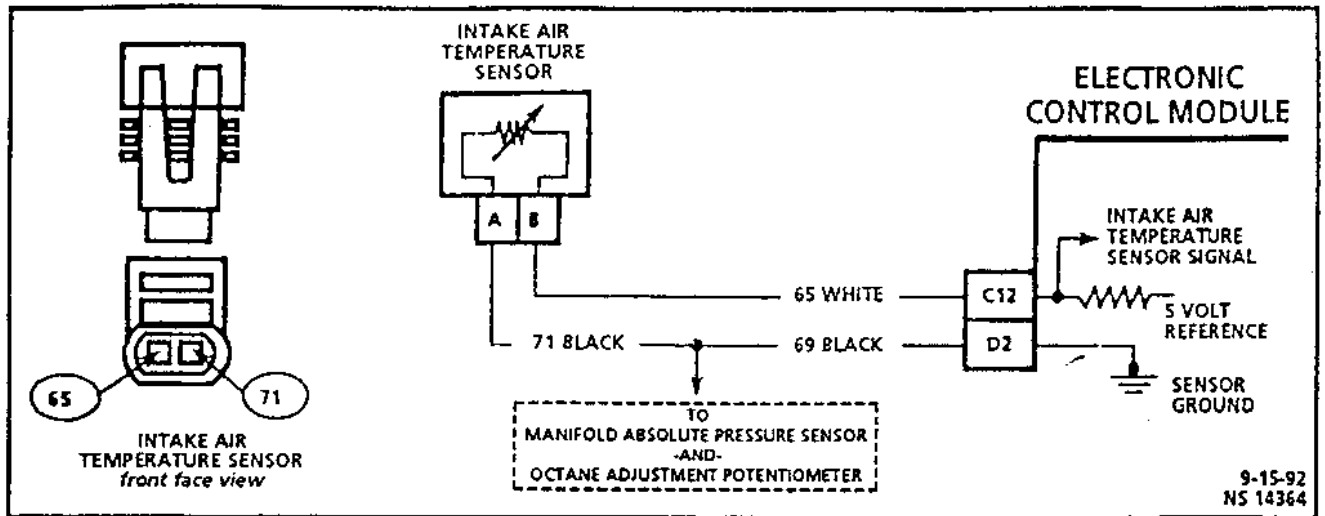

**CODE 23**  
**INTAKE AIR TEMPERATURE**  
**(SIGNAL VOLTAGE TOO HIGH)**  
**1.7L THROTTLE BODY INJECTION NIVA**

**Circuit Description:**

The intake air temperature sensor uses a thermistor to control the signal voltage to the electronic control module. The electronic control module applies a voltage (about 5 volts) on Circuit 65 White wire to the sensor. When the intake air is cold the sensor (thermistor) resistance is high, therefore, the electronic control module will see a high signal voltage. As the air warms, the sensor resistance becomes low, therefore, the electronic control module will see a low voltage.

The intake air temperature sensor is located in the air cleaner.

**Test Description:** Number(s) below refer to circled number(s) on the diagnostic chart.

1. Code 23 will set if:
  - Ignition "ON."
 OR
  - Engine has been running longer than 29 seconds.
  - Intake air temperature sensor signal voltage indicates an intake air temperature below 39°C.
2. A Code 23 will set due to an open sensor wire or connection. This test will determine if the wiring and electronic control module are OK.
3. This will determine if the signal Circuit 65 White wire or the intake air temperature sensor ground Circuit 69/71 Black wire is open.

**Diagnostic Aids:**

A Tech 1 "Scan" tool reads temperature of the air entering the engine and should read close to ambient air temperature when engine is cold, and rises as engine compartment temperature increases.

A faulty connection or an open in Circuit 65 White wire or Circuit 69/71 Black wire will result in a Code 23 and or Code 33, Code 54.

Refer to Intermittents in "Symptoms," Section "2.9B".

**CODE 23**  
**INTAKE AIR TEMPERATURE**  
**(SIGNAL VOLTAGE TOO HIGH)**  
**1.7L THROTTLE BODY INJECTION NIVA**

1 • DOES TECH 1 SCAN TOOL DISPLAY INTAKE AIR TEMPERATURE -30°C OR COLDER?

YES

NO

2 • DISCONNECT INTAKE AIR TEMPERATURE SENSOR.  
 • JUMPER HARNESS TERMINALS "A" AND "B" TOGETHER.  
 • TECH 1 SCAN TOOL SHOULD DISPLAY TEMPERATURE OVER 130°C. DOES IT?

CODE 23 IS INTERMITTENT. IF NO ADDITIONAL CODES WERE STORED, REFER TO "DIAGNOSTIC AIDS" ON FACING PAGE.

YES

NO

FAULTY CONNECTION OR FAULTY SENSOR.

3

• USING CONNECTOR TERMINAL TEST ADAPTER KIT J 35616 TO JUMPER CIRCUIT 65 WHITE WIRE TO GROUND.  
 • TECH 1 SCAN TOOL SHOULD DISPLAY TEMPERATURE OVER 130°C. DOES IT?

YES

NO

OPEN SENSOR GROUND CIRCUIT 69/71 BLACK WIRE, OR FAULTY CONNECTION OR FAULTY ELECTRONIC CONTROL MODULE.

OPEN CIRCUIT 65 WHITE WIRE, OR FAULTY CONNECTION OR FAULTY ELECTRONIC CONTROL MODULE.

**DIAGNOSTIC AID**

| INTAKE AIR TEMPERATURE SENSOR                   |  |        |
|---|--|--------|
| TEMPERATURE VS. RESISTANCE VALUES (APPROXIMATE) |  |        |
| °C  |  | OHMS   |
| 100   |  | 177    |
| 90  |  | 241    |
| 80  |  | 332    |
| 70  |  | 467    |
| 60  |  | 667    |
| 50  |  | 973    |
| 45  |  | 1188   |
| 40  |  | 1459   |
| 35  |  | 1802   |
| 30  |  | 2238   |
| 25  |  | 2796   |
| 20  |  | 3520   |
| 15  |  | 4450   |
| 10  |  | 5670   |
| 5   |  | 7280   |
| 0   |  | 9420   |
| -5  |  | 12300  |
| -10   |  | 16180  |
| -15   |  | 21450  |
| -20   |  | 28680  |
| -30   |  | 52700  |
| -40   |  | 100700 |

"AFTER REPAIRS," START ENGINE. CLEAR CODES AND CONFIRM NO "CHECK ENGINE" LIGHT.

5-26-92  
 NS 14343

## 2-70 ENGINE MANAGEMENT SYSTEMS 1.7L THROTTLE BODY INJECTION

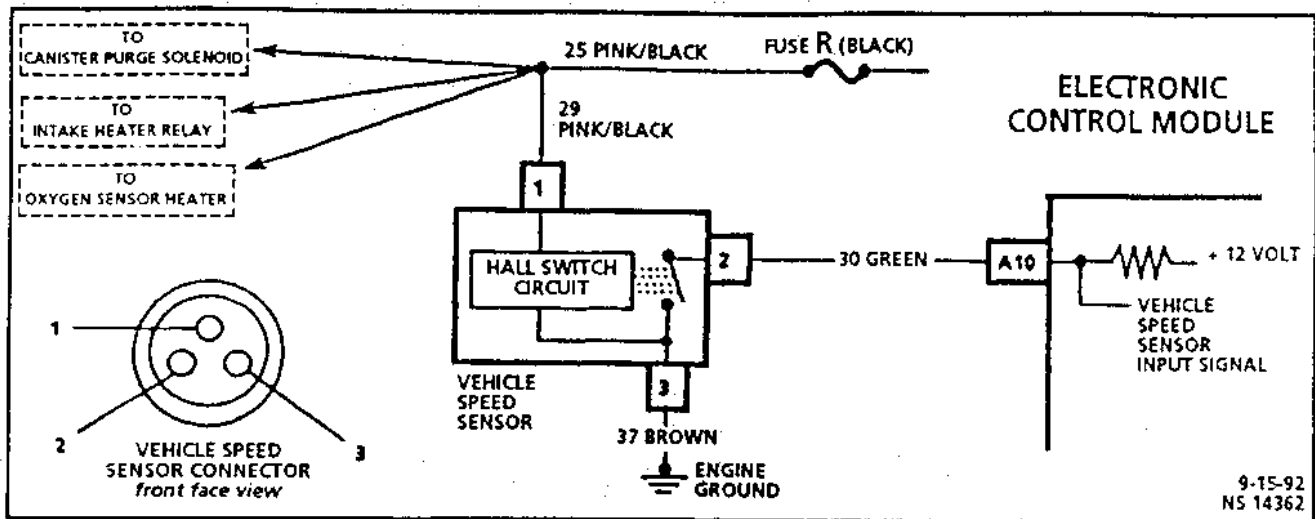

### CODE 24

#### NO VEHICLE SPEED SIGNAL 1.7L THROTTLE BODY INJECTION NIVA

##### Circuit Description:

The electronic control module terminal "A10" applies and monitors 12 volts on vehicle speed sensor input signal Circuit 30 Green wire. The vehicle speed sensor alternately grounds vehicle speed sensor input signal circuit when the drive wheels are turning. This pulsing action takes place about 1242 times per kilometer and the electronic control module calculates vehicle speed based on the time between "pulses."

Tech 1 "Scan" tool reading should closely match the speedometer reading with the drive wheels turning and vehicle speed over about 3 km/h.

Disregard a Code 24 set when drive wheels are not turning.

**Test Description:** Number(s) below refer to circled number(s) on the diagnostic chart.

Code 24 will set if the following conditions exist for longer than 3 seconds.

- Codes 21, 22, 33 and 34 are not set.
  - Engine revolutions per minute are between 2000 and 4400.
  - Manifold absolute pressure is less than 23 kPa.
  - The throttle is closed.
  - Vehicle speed signal indicates less than or equal to 10 km/h.
1. This test uses the "Scan" tool to verify the vehicle speed sensor operation.
  2. The electronic control module supplies 12 volts to vehicle speed sensor input signal circuit but this signal will not light the test light. This step verifies that vehicle speed sensor input signal circuit is not shorted to a voltage source.
  3. By probing vehicle speed sensor input signal circuit with the test light several times a second a vehicle speed signal should be generated and displayed on the "Scan" tool.
  4. This test must be done using a voltmeter and will check for the 12 volts being supplied to vehicle speed sensor input signal circuit by the electronic control module.
  5. This is the ignition feed circuit that supplies operating power to the vehicle speed sensor.
  6. This circuit supplies the ground path for vehicle speed sensor operation. If this circuit is open, vehicle speed sensor cannot pulse vehicle speed sensor input signal circuit to ground.

##### Diagnostic Aids:

The Tech 1 "Scan" tool should indicate a vehicle speed whenever the drive wheels are turning greater than 3 km/h.

If vehicle speed signal is not present, engine may stall at closed throttle coastdown speeds due to wrong vehicle speed data to electronic control module.

Refer to "Intermittents" in "Symptoms," Section "2.9B".

## CODE 24 NO VEHICLE SPEED SIGNAL 1.7L THROTTLE BODY INJECTION NIVA

DISREGARD CODE 24, IF SET WHILE DRIVE WHEELS ARE NOT TURNING

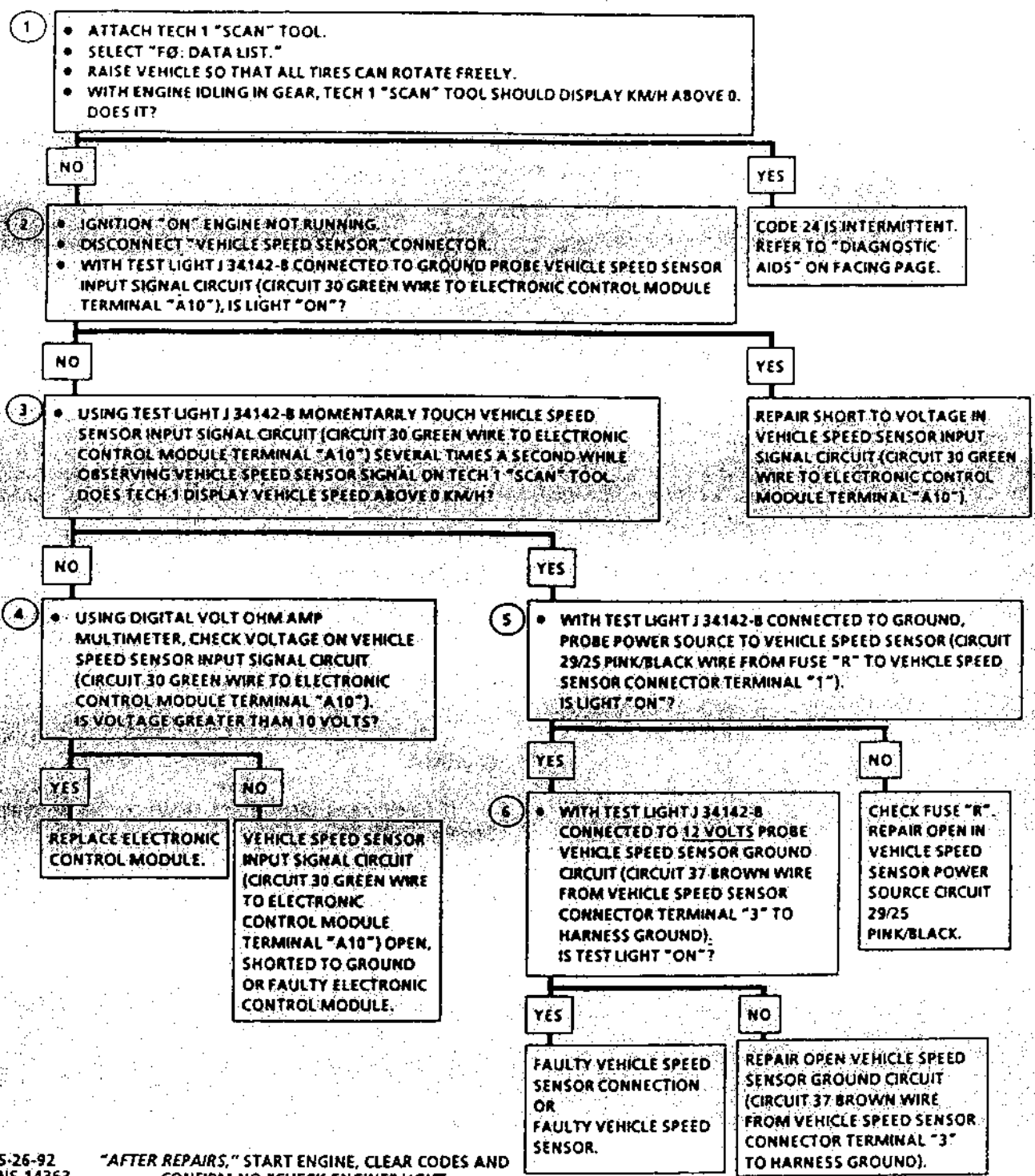

5-26-92 NS 14363 "AFTER REPAIRS," START ENGINE, CLEAR CODES AND CONFIRM NO "CHECK ENGINE" LIGHT.

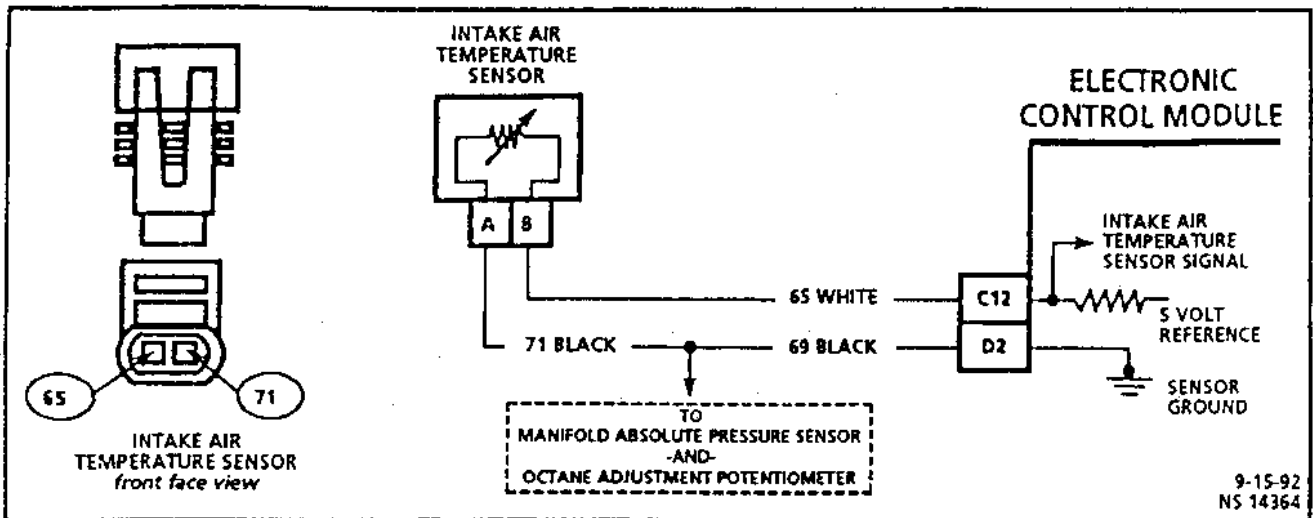

**CODE 25**  
**INTAKE AIR TEMPERATURE**  
**(SIGNAL VOLTAGE TOO LOW)**  
**1.7L THROTTLE BODY INJECTION NIVA**

**Circuit Description:**

The intake air temperature sensor uses a thermistor to control the signal voltage to the electronic control module. The electronic control module applies a voltage (about 5 volts) on Circuit 65 White to the sensor. When intake air is cold, the sensor (thermistor) resistance is high. Therefore, the electronic control module will see a high signal voltage. As the air warms, the sensor resistance becomes less and the voltage drops.

**Test Description:** Number(s) below refer to circled number(s) on the diagnostic chart.

A Code 25 will set if:

1. Intake air temperature greater than 140°C is detected for approximately 1 second with the engine running.

**Diagnostic Aids:**

If the engine has been allowed to cool to an ambient temperature (overnight), the coolant temperature and intake air temperature may be checked with a Tech 1 "Scan" tool and should read close to each other.

A Code 25 will result if Circuit 65 White is shorted to ground.

If Code 25 is intermittent, refer to "Symptoms," Section "2.9B."

**CODE 25**  
**INTAKE AIR TEMPERATURE**  
**(SIGNAL VOLTAGE TOO LOW)**  
**1.7L THROTTLE BODY INJECTION NIVA**

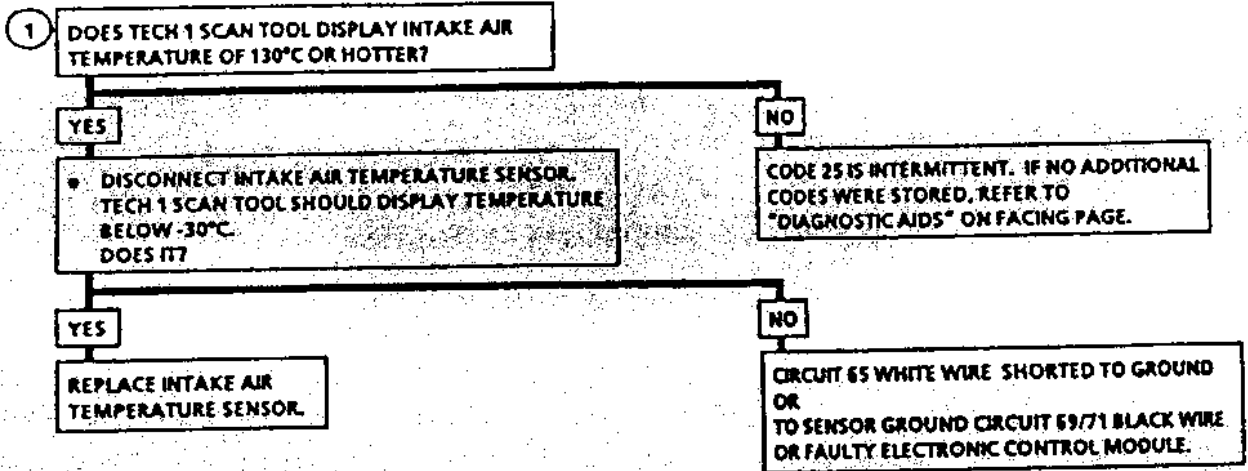

**DIAGNOSTIC AID**

| INTAKE AIR TEMPERATURE SENSOR                   |  |        |
|---|--|--------|
| TEMPERATURE VS. RESISTANCE VALUES (APPROXIMATE) |  |        |
| °C  |  | OHMS   |
| 100   |  | 177    |
| 90  |  | 241    |
| 80  |  | 332    |
| 70  |  | 467    |
| 60  |  | 667    |
| 50  |  | 973    |
| 45  |  | 1188   |
| 40  |  | 1459   |
| 35  |  | 1802   |
| 30  |  | 2238   |
| 25  |  | 2796   |
| 20  |  | 3520   |
| 15  |  | 4450   |
| 10  |  | 5670   |
| 5   |  | 7280   |
| 0   |  | 9420   |
| -5  |  | 12300  |
| -10   |  | 16180  |
| -15   |  | 21450  |
| -20   |  | 28680  |
| -30   |  | 52700  |
| -40   |  | 100700 |

"AFTER REPAIRS," START ENGINE, CLEAR CODES AND CONFIRM NO "CHECK ENGINE" LIGHT.

5-26-92  
 NS 14365

## 2-74 ENGINE MANAGEMENT SYSTEMS 1.7L THROTTLE BODY INJECTION

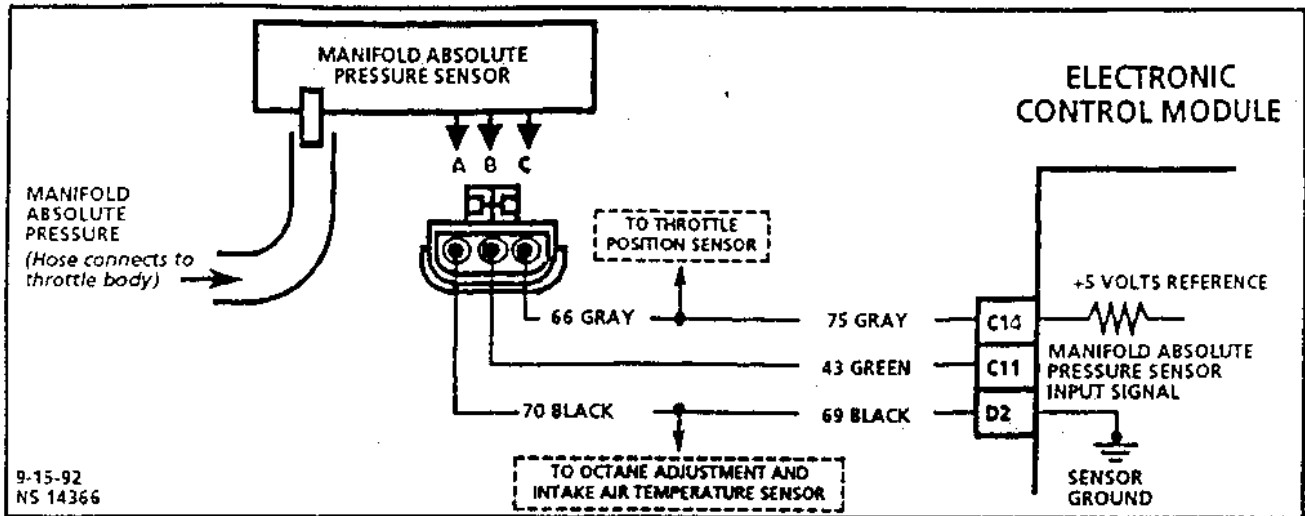

### CODE 33 MANIFOLD ABSOLUTE PRESSURE (SIGNAL VOLTAGE TOO HIGH) 1.7L THROTTLE BODY INJECTION NIVA

#### Circuit Description:

The manifold absolute pressure sensor responds to changes in intake manifold pressure. The electronic control module receives this information as a signal voltage that will vary from about 1–1.5 volts at idle to 4–4.5 volts at wide open throttle.

The Tech 1 "Scan" tool displays manifold pressure in volts and kilopascals pressure. Low pressure reads a low voltage while a high pressure reads a high voltage.

If the manifold absolute pressure sensor fails the electronic control module will substitute a fixed manifold absolute pressure value and use the throttle position sensor to control fuel delivery.

**Test Description:** Number(s) below refer to circled number(s) on the diagnostic chart.

- Code 33 will set if:
  - Engine has been running.
  - Malfunction Code 21 or 22 are not set.
  - Throttle position sensor less than 1.6%.
  - Manifold absolute pressure sensor signal voltage is too high (greater than 76 kPa of pressure) for a time greater than approximately five seconds.

Engine misfire or a low unstable idle may set Code 33. Disconnect manifold absolute pressure sensor electrical connector and system will use a default manifold absolute pressure value. If the misfire or idle condition remains, see "Symptoms," in Section "2.9B".

- If the electronic control module recognizes and the Tech 1 "Scan" tool displays the low manifold absolute pressure signal, the electronic control module and wiring are OK.

#### Diagnostic Aids:

If the idle is rough or unstable, refer to "Symptoms," Section "2.9B" for items which can cause an unstable idle.

An open in octane adjustment, intake air temperature sensor and manifold absolute pressure sensor ground circuit (Circuit 69/70 Black wire from manifold absolute pressure sensor connector terminal "A" to electronic control module terminal "D2") will result in a Code 33, and/or Code 23 and Code 54.

With the ignition "ON" and the engine not running, the manifold pressure is equal to atmospheric pressure and the signal voltage may be high. This information is used by the electronic control module as an indication of vehicle altitude and is referred to as barometric pressure. Comparison of this barometric reading with a sensor in a known good vehicle is a good way to check accuracy of a "suspect" sensor, the reading should be the same +0.2 volt. Also, CHART C-1D can be used to test the manifold absolute pressure sensor.

Refer to "Intermittents" in "Symptoms," Section "2.9B".

If vacuum hose is disconnected or leaking, idle air control counts will be close to zero (0) and engine may idle with high engine speed.

**CODE 33**

**MANIFOLD ABSOLUTE PRESSURE  
(SIGNAL VOLTAGE TOO HIGH)  
1.7L THROTTLE BODY INJECTION NIVA**

1

- CONNECT TECH 1 "SCAN" TOOL.
- SELECT "FB: DATA LIST."
- ENGINE IDLING.
- IF ENGINE IDLE IS ROUGH, UNSTABLE, OR INCORRECT, CORRECT CONDITION BEFORE USING THIS CHART. SEE "SYMPTOMS" IN SECTION "B".

DOES TECH 1 "SCAN" TOOL DISPLAY A MANIFOLD ABSOLUTE PRESSURE VOLTAGE OF 4.0 VOLTS OR MORE?

NO → CODE 33 IS INTERMITTENT. IF NO ADDITIONAL CODES WERE STORED, REFER TO "DIAGNOSTIC AIDS" ON FACING PAGE.

YES →

2

- IGNITION "OFF" FOR AT LEAST 15 SECONDS.
- DISCONNECT MANIFOLD ABSOLUTE PRESSURE SENSOR ELECTRICAL CONNECTOR.
- IGNITION "ON," ENGINE NOT RUNNING.

DOES TECH 1 DISPLAY A MANIFOLD ABSOLUTE PRESSURE VOLTAGE OF 1 VOLT OR LESS?

NO → MANIFOLD ABSOLUTE PRESSURE SENSOR INPUT SIGNAL CIRCUIT (CIRCUIT 43 GREEN WIRE FROM MANIFOLD ABSOLUTE PRESSURE SENSOR TERMINAL "B" TO ELECTRONIC CONTROL MODULE TERMINAL "C13") SHORTED TO VOLTAGE, OR SHORTED TO +5VOLT REFERENCE CIRCUIT (GRAY WIRE FROM MANIFOLD ABSOLUTE PRESSURE SENSOR TERMINAL "C" TO ELECTRONIC CONTROL MODULE TERMINAL "C14") OR FAULTY ELECTRONIC CONTROL MODULE.

YES →

- WITH A TEST LIGHT J-34142-B TO + BATTERY VOLTAGE PROBE MANIFOLD ABSOLUTE PRESSURE SENSOR GROUND CIRCUIT (CIRCUIT 69/70 BLACK WIRE FROM MANIFOLD ABSOLUTE PRESSURE SENSOR TERMINAL "A" TO ELECTRONIC CONTROL MODULE TERMINAL "D2"). DOES TEST LIGHT LIGHT?

NO → OPEN MANIFOLD ABSOLUTE PRESSURE SENSOR GROUND CIRCUIT (CIRCUIT 69/70 BLACK WIRE FROM MANIFOLD ABSOLUTE PRESSURE SENSOR TERMINAL "A" TO ELECTRONIC CONTROL MODULE TERMINAL "D2").

YES →

PLUGGED OR LEAKING SENSOR VACUUM HOSE, FAULTY VACUUM SOURCE OR FAULTY MANIFOLD ABSOLUTE PRESSURE SENSOR.

"AFTER REPAIRS," START ENGINE, CLEAR CODES AND CONFIRM NO "CHECK ENGINE" LIGHT.

2-5-93  
NS 14367



## 2-76 ENGINE MANAGEMENT SYSTEMS 1.7L THROTTLE BODY INJECTION

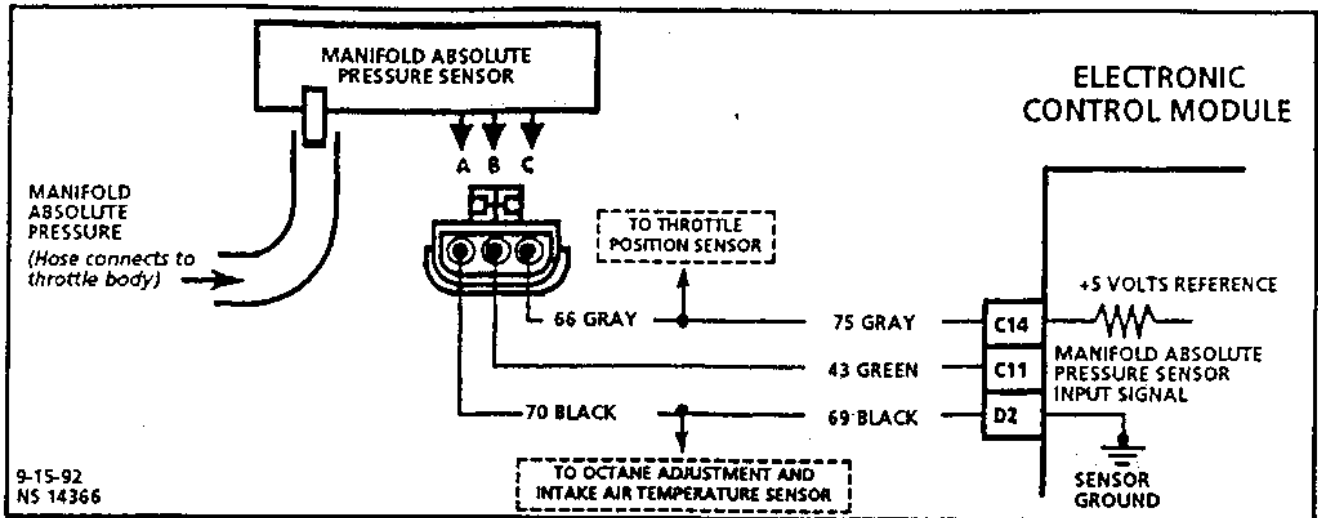

### CODE 34

### MANIFOLD ABSOLUTE PRESSURE (SIGNAL VOLTAGE TOO LOW) 1.7L THROTTLE BODY INJECTION NIVA

#### Circuit Description:

The manifold absolute pressure sensor responds to changes in intake manifold pressure. The electronic control module receives this information as a signal voltage that will vary from about 1–1.5 volts at idle to 4–4.5 volts at wide open throttle.

The Tech 1 "Scan" tool displays manifold pressure in voltage and kilopascals pressure. Low pressure reads a low voltage while a high pressure reads a high voltage.

If the manifold absolute pressure sensor fails the electronic control module will substitute a fixed manifold absolute pressure value and use the throttle position sensor to control fuel delivery.

**Test Description:** Number(s) below refer to circled number(s) on the diagnostic chart.

- Code 34 will set if:
  - Malfunction Code 21 is not set.
  - Engine speed is less than 1200 revolutions per minute.
  - Manifold absolute pressure sensor signal voltage is too low (less than 14 kPa of pressure) for less than one second.

OR

  - Malfunction Code 21 is not set.
  - Engine speed is greater than 1200 revolutions per minute.
  - Throttle position greater than 20%.
  - Manifold absolute pressure sensor signal voltage is too low (less than 14 kPa of pressure) for less than one second.
- If the electronic control module recognizes the high manifold absolute pressure signal, the electronic control module and wiring are OK.

- The Tech 1 "Scan" tool may not display 12 volts. The important thing is that the electronic control module recognizes the voltage as more than 4 volts, indicating that the electronic control module and manifold absolute pressure sensor input signal circuit are OK.

#### Diagnostic Aids:

An intermittent open in manifold absolute pressure sensor input signal circuit or +5 volt reference circuit will result in a Code 34.

With the ignition "ON" and the engine not running, the manifold pressure is equal to atmospheric pressure and the signal voltage will be high. This information is used by the electronic control module as an indication of vehicle altitude and is referred to as barometric pressure. Comparison of this barometric reading with a sensor in a known good vehicle is a good way to check accuracy of a "suspect" sensor, the reading should be the same  $\pm 0.2$  volt. Also, CHART C-1D can be used to test the manifold absolute pressure sensor.

Refer to "Intermittents" in "Symptoms," Section "2.9B".

**CODE 34**  
**MANIFOLD ABSOLUTE PRESSURE**  
**(SIGNAL VOLTAGE TOO LOW)**  
**1.7L THROTTLE BODY INJECTION NIVA**

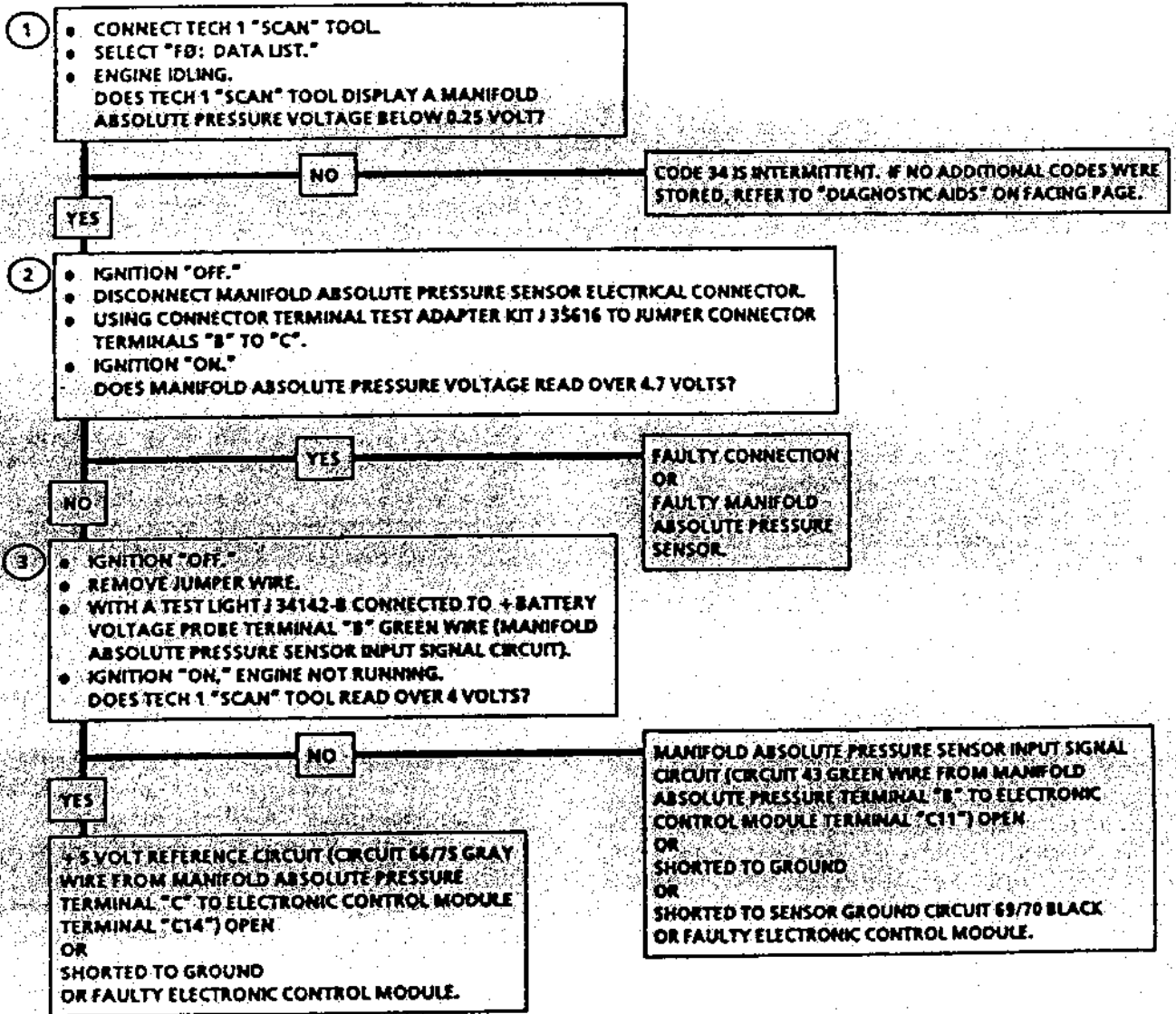

"AFTER REPAIRS," START ENGINE, CLEAR CODES AND CONFIRM NO "CHECK ENGINE" LIGHT.

S-26-92  
 NS 14369

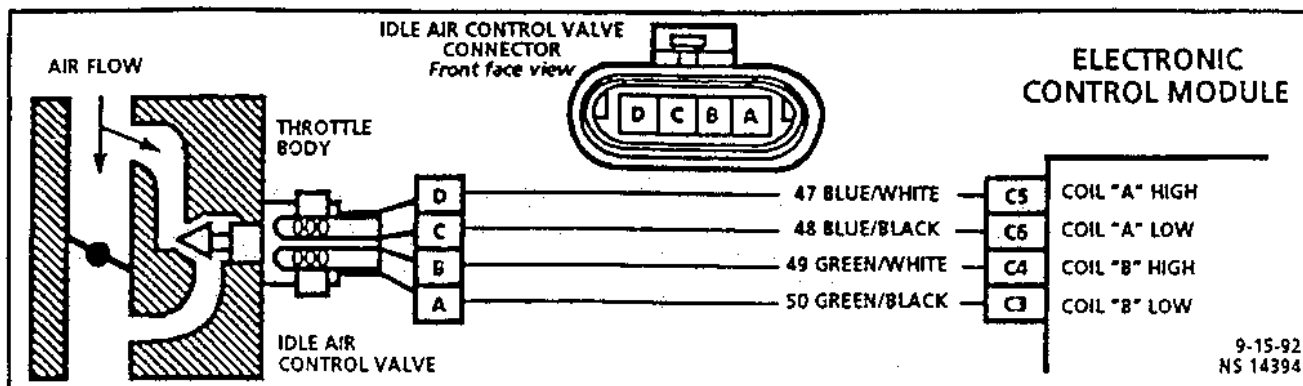

## CODE 35

### IDLE SPEED ERROR 1.7L THROTTLE BODY INJECTION NIVA

#### Circuit Description:

Code 35 will set if the closed throttle engine speed is 150 revolutions per minute above the desired (commanded) idle speed for more than 3 seconds. Review the general description of the idle air control operation in "Fuel Metering System," Section "1.2".

**Test Description:** Number(s) below refer to circled number(s) on the diagnostic chart.

- The Tech 1 "Scan" tool revolutions per minute control mode is used to extend and retract the Idle air control valve. The valve should move smoothly within the specified range. If the idle speed is commanded (idle air control extended) too low (below 700 revolutions per minute), the engine may stall. This may be normal and would not indicate a problem. Retracting the idle air control beyond its controlled range (above 1500 revolutions per minute) will cause a delay before the revolutions per minute start dropping. This too is normal.
- This test uses the Tech 1 "Scan" tool to command the idle air control controlled idle speed. The electronic control module issues commands to obtain commanded idle speed. The node lights each should flash red and green to indicate a good circuit as the electronic control module issues commands. While the sequence of color is not important if either light is "OFF" or does not flash red and green, check the circuits for faults, beginning with poor terminal contacts.

#### Diagnostic Aids:

A slow, unstable, or fast idle may be caused by a non-idle air control system problem that cannot be overcome by the idle air control valve. Out of control range idle air control "Scan" tool counts will be above 60 if idle is too low and zero counts if idle is too high. The following checks should be made to repair a non-idle air control system problem:

- Vacuum Leak (High Idle)** - If idle is too high, stop the engine. Fully extend (low) idle air control with tester. Start engine. If idle speed is above 800 revolutions per minute, locate and correct vacuum leak including crankcase ventilation system. Also check for binding of throttle blade or linkage.
- System too lean (High Air/Fuel Ratio)** - The idle speed may be too high or too low. Engine speed may vary up and down and disconnecting the idle air control valve does not help. Code 44 may be set. Tech 1 "Scan" tool oxygen voltage will be less than 300 mV (0.3 volt). Check for low regulated fuel pressure, water in the fuel or a restricted injector.
- System too rich (Low Air/Fuel Ratio)** - The idle speed will be too low. Tech 1 "Scan" tool idle air control counts will usually be above 80. System is obviously rich and may exhibit black smoke in exhaust. Tech 1 "Scan" tool oxygen voltage will be fixed above 800 mV (.8 volt). Check for high fuel pressure, leaking or sticking injector. Silicone contaminated oxygen sensors Tech 1 "Scan" tool voltage will be slow to respond.
- Throttle Body** - Remove idle air control valve and inspect bore for foreign material.
- Idle Air Control Valve Electrical Connections** - Idle air control valve connections should be carefully checked for proper contact.
- Crankcase Ventilation System** - An incorrect or faulty positive crankcase ventilation system may result in an incorrect idle speed. Refer to CHART C-13.
- Refer to "Rough, Unstable, Incorrect Idle or Stalling" in "Symptoms," Section "2.9B".
- If intermittent poor driveability or idle symptoms are resolved by disconnecting the idle air control, carefully recheck connections, valve terminal resistance or replace idle air control.

**CODE 35**  
**IDLE SPEED ERROR**  
**1.7L THROTTLE BODY INJECTION NIVA**

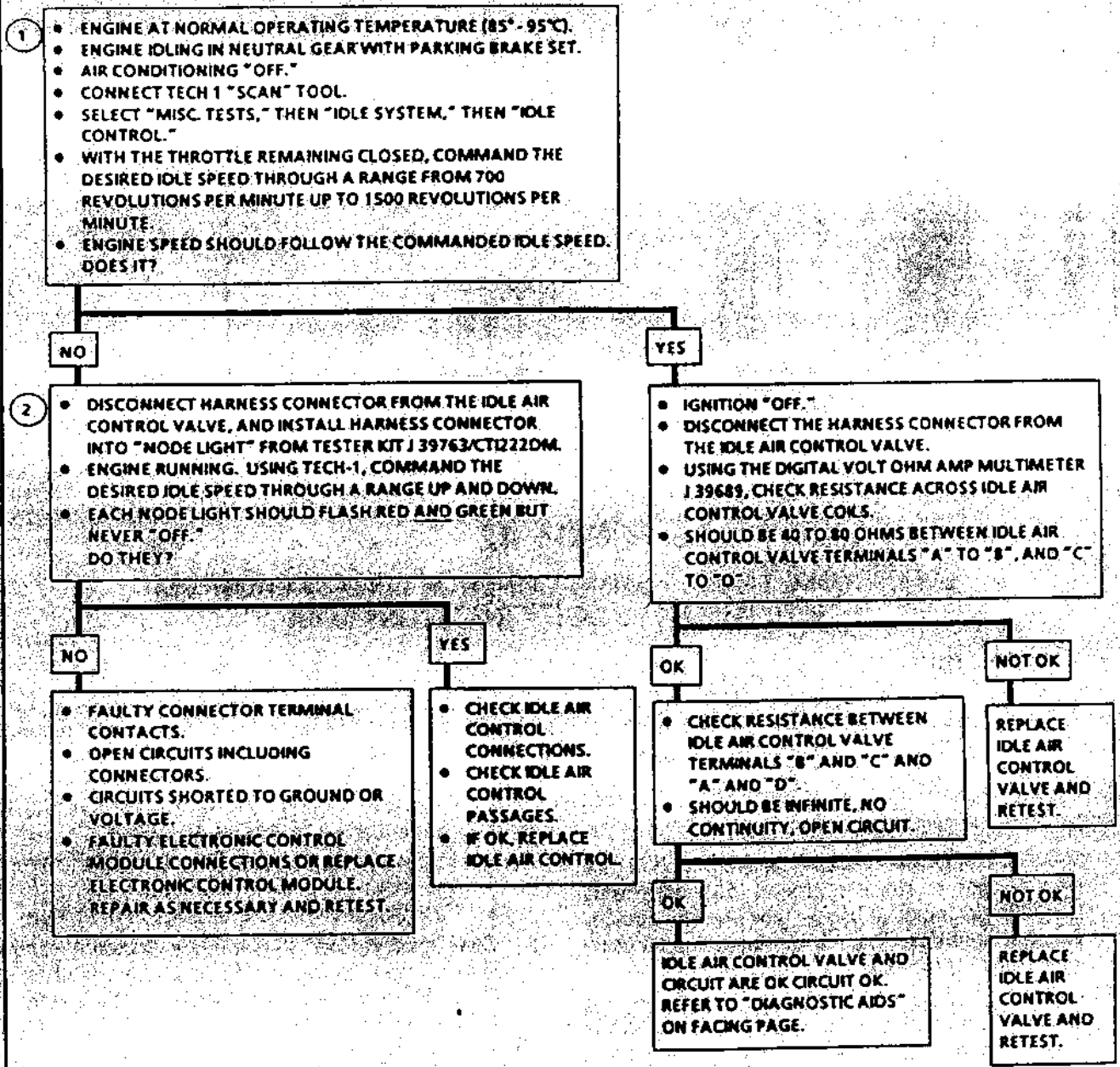

AFTER ALL IDLE AIR CONTROL TESTING IS COMPLETE, RESET THE IDLE AIR CONTROL VALVE. CONNECT TECH 1, SELECT "MISC. TESTS," THEN "IDLE SYSTEM," THEN "IDLE RESET."

"AFTER REPAIRS," START ENGINE, CLEAR CODES AND CONFIRM NO "CHECK ENGINE" LIGHT.

3-9-93  
 NS 14378

## 2-80 ENGINE MANAGEMENT SYSTEMS 1.7L THROTTLE BODY INJECTION

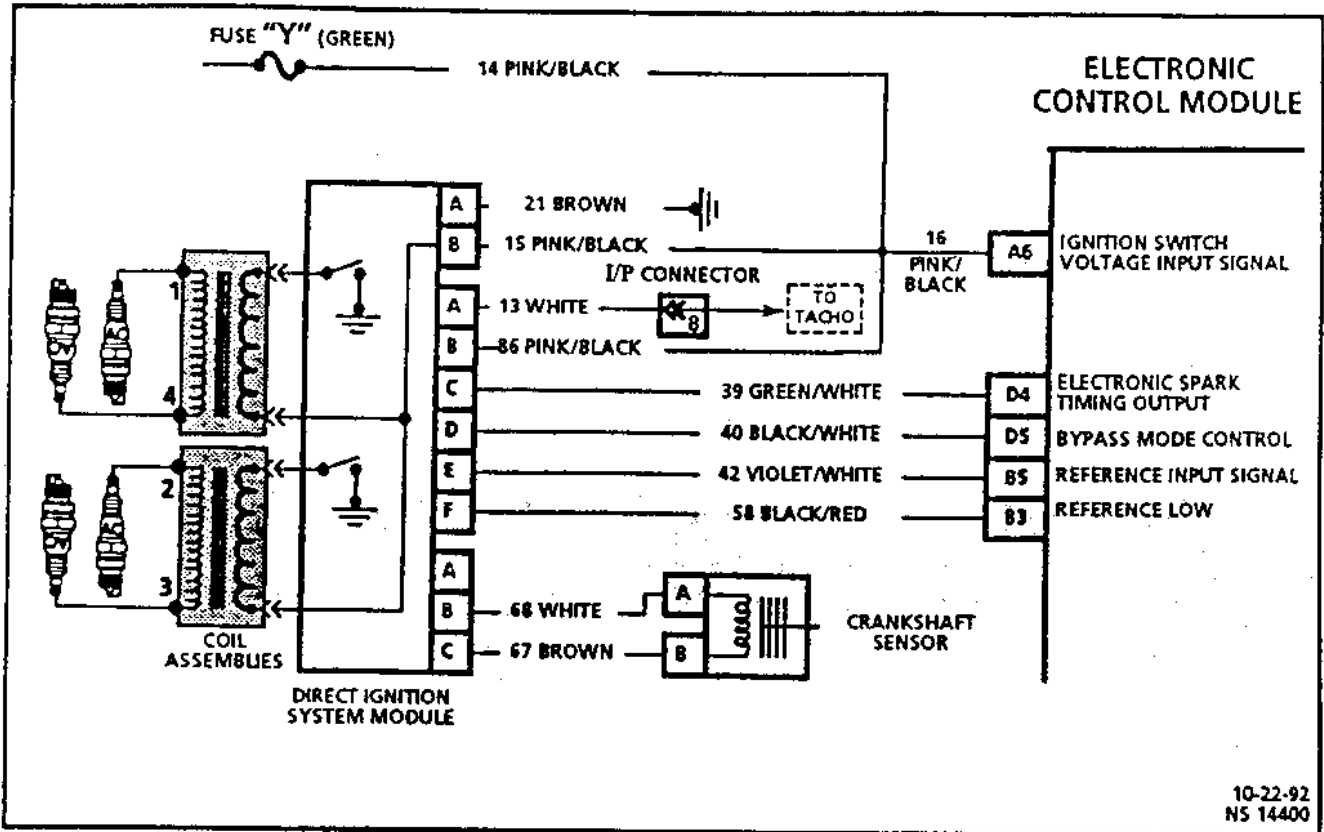

### CODE 42

#### ELECTRONIC SPARK TIMING CONTROL CIRCUIT PROBLEM 1.7L THROTTLE BODY INJECTION NIVA

##### Circuit Description:

Code 42 will set if the electronic control module detects an improper signal on either the bypass mode control circuit 40 Black/White wire or the electronic spark timing output circuit 39 Green/White wire when the engine is cranking or while running. Review the general description of the ignition system in Section 1.4.

**Test Description:** Number(s) below refer to circled number(s) on the diagnostic chart.

- Code 42 means the electronic control module has seen an open or short to ground in the electronic spark timing output or bypass mode control circuits. This test confirms Code 42 and that the fault causing the code is present.
- Checks for a normal electronic spark timing ground path through the ignition module. An electronic spark timing Circuit 39 Green/White wire shorted to ground will also read less than 500 ohms; however, this will be checked later.
- As the test light voltage touches Circuit 40 Black/White wire, the module should switch, causing the ohmmeter to "switch ranges," if the meter is in the low ohms position. The important thing is that the module "switched" above 500 ohms.
- The ignition module did not switch and this step checks for:

- Electronic spark timing output Circuit 39 Green/White wire shorted to ground.
  - Bypass mode control Circuit 40 Black/White wire open.
  - Faulty ignition module connection or module.
- Confirms that Code 42 is a faulty electronic control module and not an intermittent in Circuits 39 Green/White wire or Circuit 40 Black/White wire.

##### Diagnostic Aids:

An open or ground in the electronic spark timing circuit will result in the engine continuing to run, but in a "bypass" ignition timing mode (ignition module timing) at a calculated timing value and the "Check Engine" light will not be "ON." If the electronic spark timing fault is still present the next time the engine is restarted, a Code 42 will be set and the engine will operate in module timing.

If Code 42 is intermittent, refer to Section "2.9B".

**CODE 42**  
**ELECTRONIC SPARK TIMING**  
**CONTROL CIRCUIT PROBLEM**  
**1.7L THROTTLE BODY**  
**INJECTION NIVA**

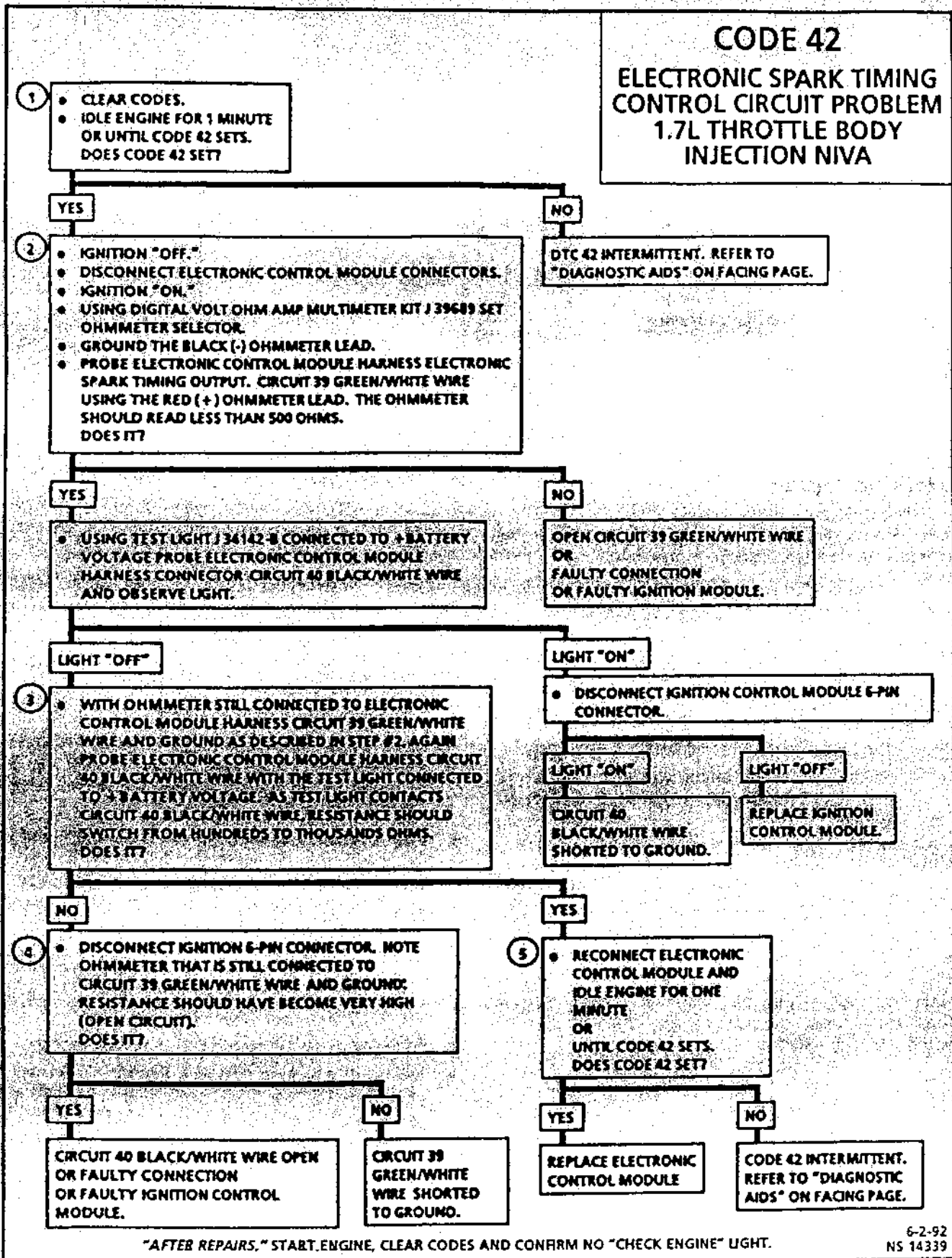

"AFTER REPAIRS," START ENGINE, CLEAR CODES AND CONFIRM NO "CHECK ENGINE" LIGHT.

6-2-92  
 NS 14339

## 2-82 ENGINE MANAGEMENT SYSTEMS 1.7L THROTTLE BODY INJECTION

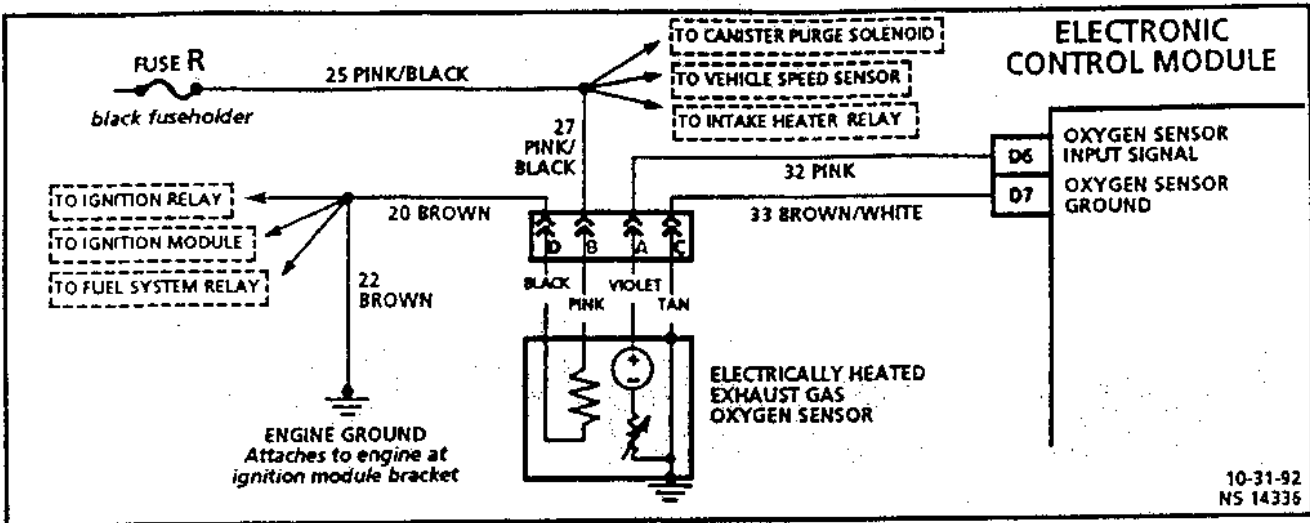

### CODE 44 LEAN EXHAUST INDICATION 1.7L THROTTLE BODY INJECTION NIVA

#### Circuit Description:

The electronic control module applies a reference voltage of about 450 millivolts between terminals "D7" and "D6". The oxygen sensor varies the voltage within a range of about 1 volt, if the exhaust is rich, down through about 10 millivolt, if exhaust is lean. A lean exhaust condition will cause the oxygen sensor to output a low voltage.

The sensor is like an open circuit and produces no voltage when it is below about 315°C. An open sensor circuit, or cold sensor, causes "Open Loop" operation.

**Test Description:** Number(s) below refer to circled number(s) on the diagnostic chart.

1. Code 44 is set if:

- The fuel system is operating in "Closed Loop."
- The oxygen sensor signal voltage on Circuit 32 Pink wire remains below 300 millivolts for 50 seconds.

#### Diagnostic Aids:

Using the Tech 1, observe the memory fuel adjustment values at different revolutions per minute and air flow conditions. The Tech 1 also displays the memory fuel adjustment cells, so the memory fuel adjustment values can be checked in each of the cells to determine when the Code 44 may have been set. If the conditions for Code 44 exist, the memory fuel adjustment values will be close to +50%.

- Check for intermittent connection between connector and oxygen sensor.
- Poor connection at oxygen sensor ground wire.
- **Fuel Contamination:** Water, even in small amounts, near the in-tank fuel pump inlet can be delivered to the injector. The water causes a lean exhaust and can set a Code 44.
- **Fuel Pressure:** System will be lean if pressure is too low. It may be necessary to monitor fuel pressure while driving the vehicle at various road speeds and/or loads to confirm. Refer to Fuel System Diagnosis, CHART A-7.
- **Exhaust Leaks:** If there is an exhaust leak, the engine can cause outside air to be pulled into the exhaust leak and past the oxygen sensor. Vacuum or crankcase leaks can cause a lean condition.
- If the above are OK, it is a faulty oxygen sensor.
- **Manifold Absolute Pressure Sensor:** Check for a shifted sensor that could cause a lean exhaust but not set a Code 33 or 34. Refer to CHART C-ID.

**CODE 44**  
**LEAN EXHAUST INDICATION**  
**1.7L THROTTLE BODY INJECTION NIVA**

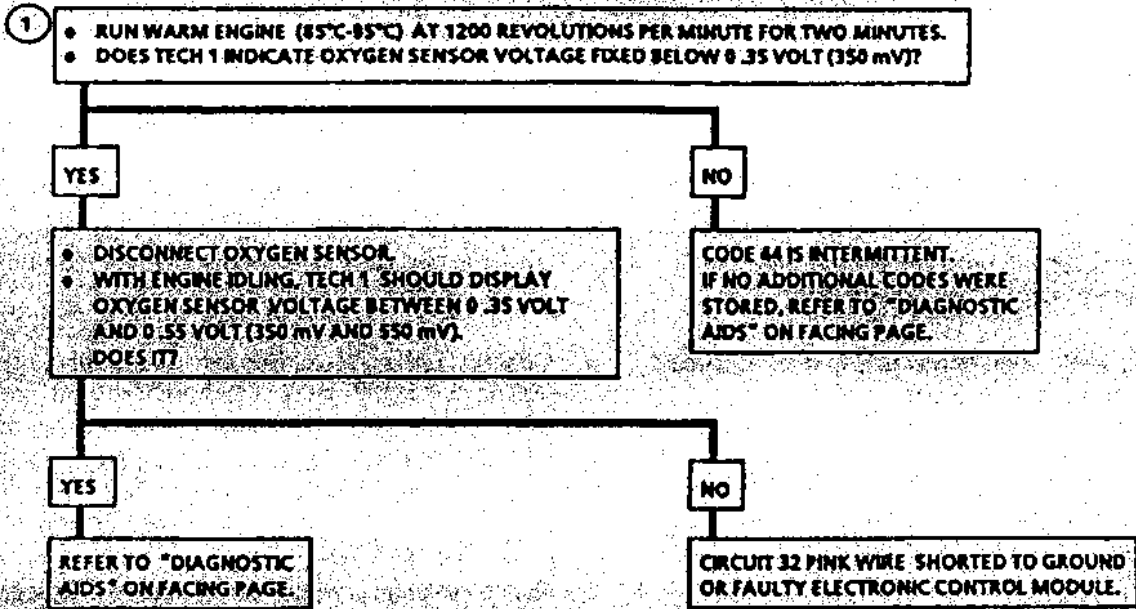

"AFTER REPAIRS," START ENGINE, CLEAR CODES AND CONFIRM NO "CHECK ENGINE" LIGHT.

5-27-92  
 NS 14438



## 2-84 ENGINE MANAGEMENT SYSTEMS 1.7L THROTTLE BODY INJECTION

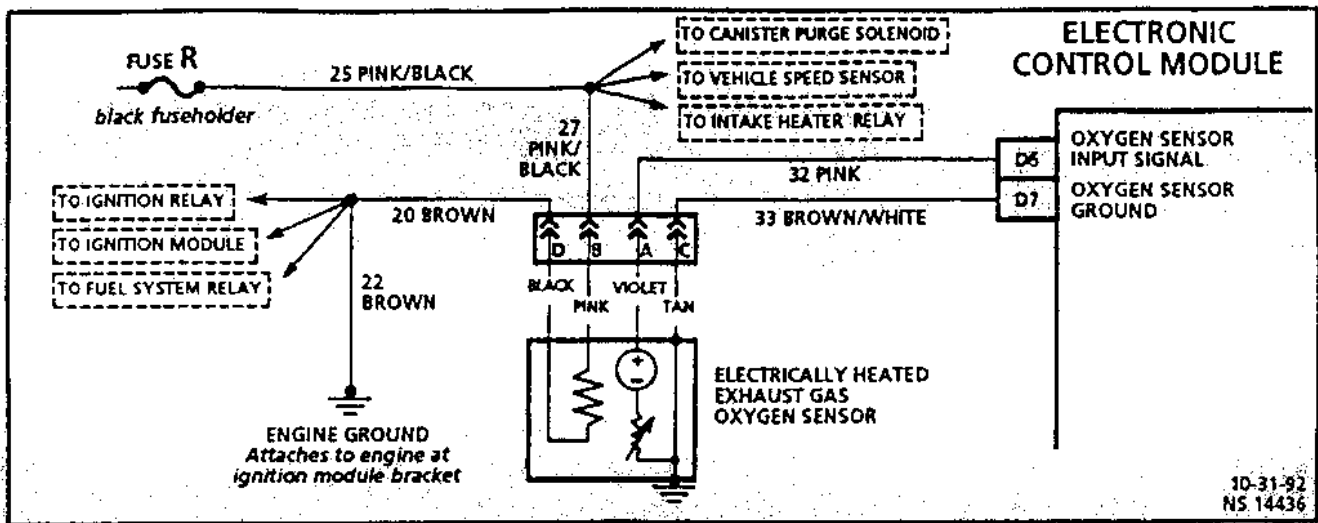

### CODE 45 RICH EXHAUST INDICATION 1.7L THROTTLE BODY INJECTION NIVA

#### Circuit Description:

The electronic control module applies a reference voltage of approximately 450 millivolts between terminals "D7" and "D6". The oxygen sensor varies the voltage within a range of about 1 volt, if the exhaust is rich, and down through about 10 millivolt, if exhaust is lean. A rich exhaust condition will cause the oxygen sensor to output a high voltage.

The sensor is like an open circuit and produces no voltage when it is below 315°C. An open sensor circuit, or a cold sensor causes "Open Loop" operation.

**Test Description:** Number(s) below refer to circled number(s) on the diagnostic chart.

- Code 45 is set if:
  - The fuel system is operating in "Closed Loop."
  - The oxygen sensor signal voltage on Circuit 32 Pink wire remains above 600 millivolts for 90 seconds.

#### Diagnostic Aids:

Using the Tech 1 "Scan" tool, observe the memory fuel adjustment values at different revolutions per minute and air flow conditions. The Tech 1 "Scan" tool also displays the memory fuel adjustment cells, so the memory fuel adjustment values can be checked in each of the cells to determine when the Code 45 may have been set. If the conditions for Code 45 exist, the memory fuel adjustment values will be close to -38.

- Coolant Temperature Sensor:** Check for a shifted sensor that could cause a rich exhaust but not set Code 15, see Code 15 for sensor resistance values.
- Throttle Position Sensor:** An intermittent throttle position sensor output will cause the system to go rich, due to a false indication of the engine accelerating. Refer to CHART C-1H.
- Fuel Pressure:** System will go rich if pressure is too high. The electronic control module can compensate for some increase. However, if it gets too high, a Code 45 may be set. Check for a pinched fuel return line, or plugged vacuum hose to fuel pressure regulator. See Fuel System Diagnosis, CHART A-7.
- Leaking Injector:** Refer to CHART A-7. Check for fuel contaminated oil.
- Canister Purge:** Check for fuel saturation. If full of fuel, check canister control and hoses. Refer to CHART C-3.
- Manifold Absolute Pressure Sensor:** Check for a shifted sensor that could cause a rich exhaust but not set a Code 33 or 34. Refer to CHART C-1D.

**CODE 45**  
**RICH EXHAUST INDICATION**  
**1.7L THROTTLE BODY INJECTION NIVA**

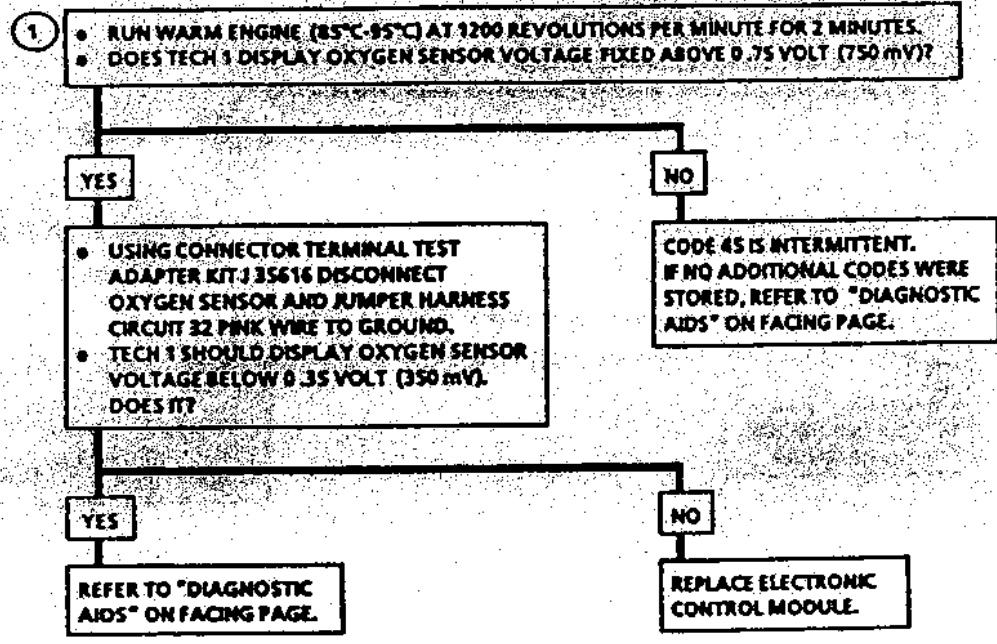

"AFTER REPAIRS," START ENGINE, CLEAR CODES AND CONFIRM NO "CHECK ENGINE" LIGHT.

6-2-92  
 NS 14439

**CODE 51**  
**CALIBRATOR ERROR**  
**1.7L THROTTLE BODY INJECTION NIVA**

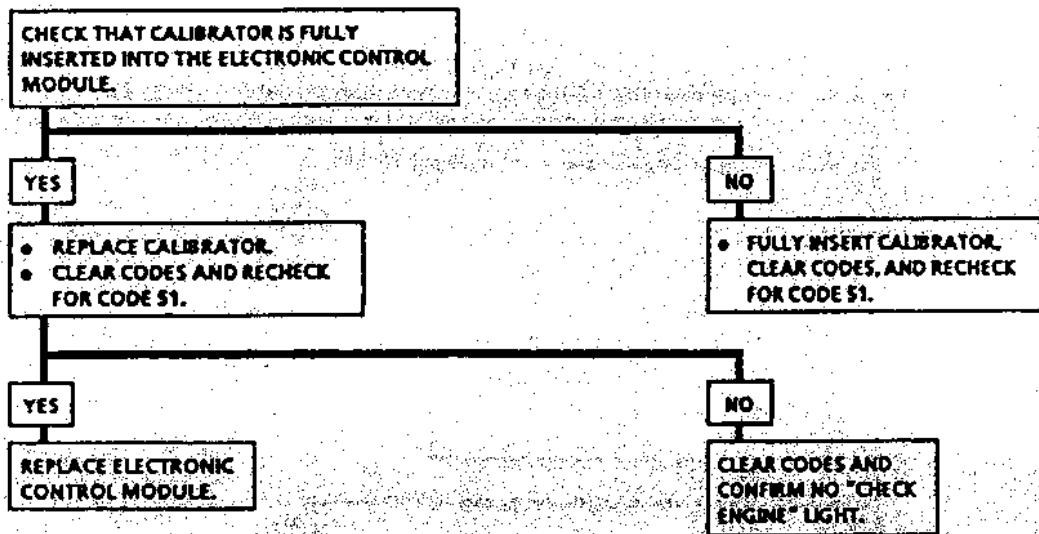

"AFTER REPAIRS," START ENGINE, CLEAR CODES AND CONFIRM NO "CHECK ENGINE" LIGHT.

5-27-92  
NS 14443

**BLANK**

## 2-88 ENGINE MANAGEMENT SYSTEMS 1.7L THROTTLE BODY INJECTION

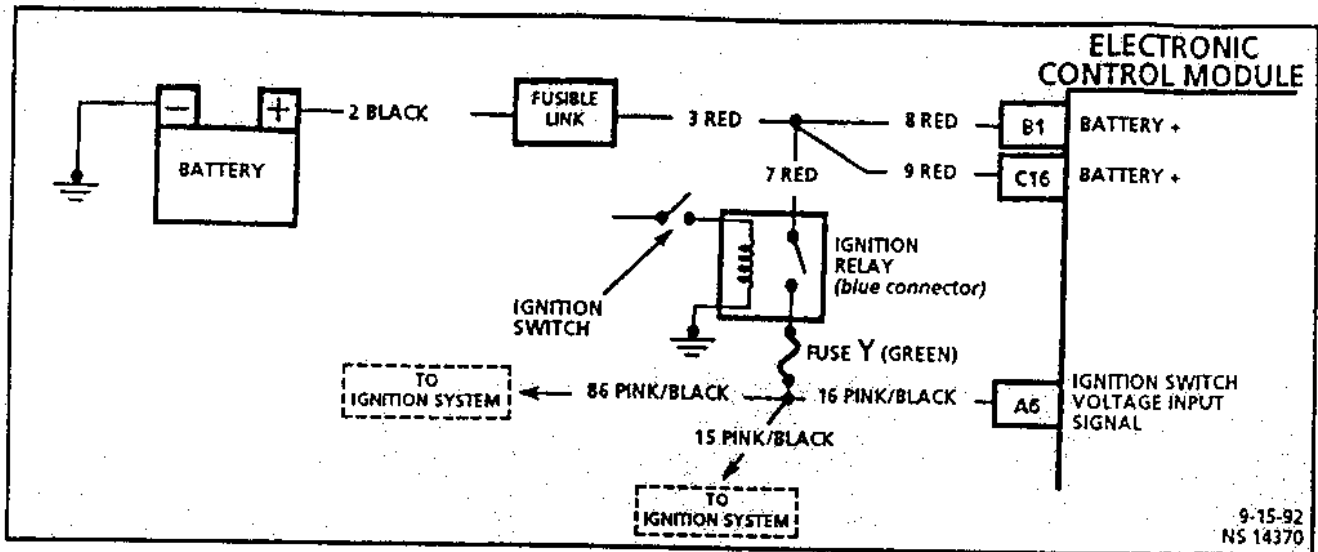

### CODE 53 SYSTEM VOLTAGE TOO HIGH 1.7L THROTTLE BODY INJECTION NIVA

#### Circuit Description:

Code 53 will set if the engine is running and the battery voltage is more than 16.9 volts for one second on electronic control module terminal "A6." During the time the fault is present, all electronic control module outputs will be disengaged and setting of additional codes may result.

**Test Description:** Number(s) below refer to circled number(s) on the diagnostic chart.

1. Normal battery output is between 12-15 volts.
2. Checks to see if the high voltage reading is due to the generator or incorrect interpretation by the electronic control module. With engine running, check voltage at the battery.
3. Checks to see if generator is faulty at higher engine speed.

#### Diagnostic Aids:

During the time the failure is present, all electronic control module outputs except the fuel injector and fuel system relay, will be disengaged to protect the hardware. The setting of additional codes may result.

**CODE 53**  
**SYSTEM VOLTAGE TOO HIGH**  
**1.7L THROTTLE BODY INJECTION NIVA**

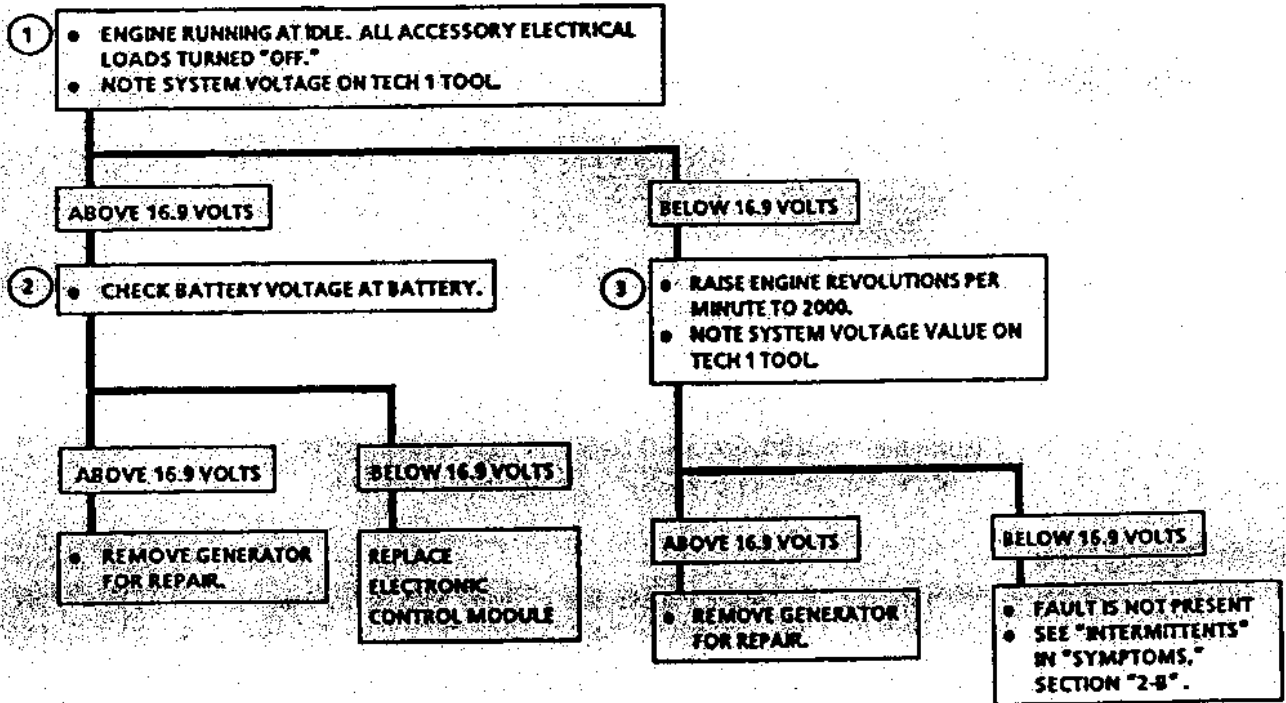

"AFTER REPAIRS," START ENGINE, CLEAR CODES AND CONFIRM NO "CHECK ENGINE" LIGHT.

6-2-92  
 NS 14371

## 2-90 ENGINE MANAGEMENT SYSTEMS 1.7L THROTTLE BODY INJECTION

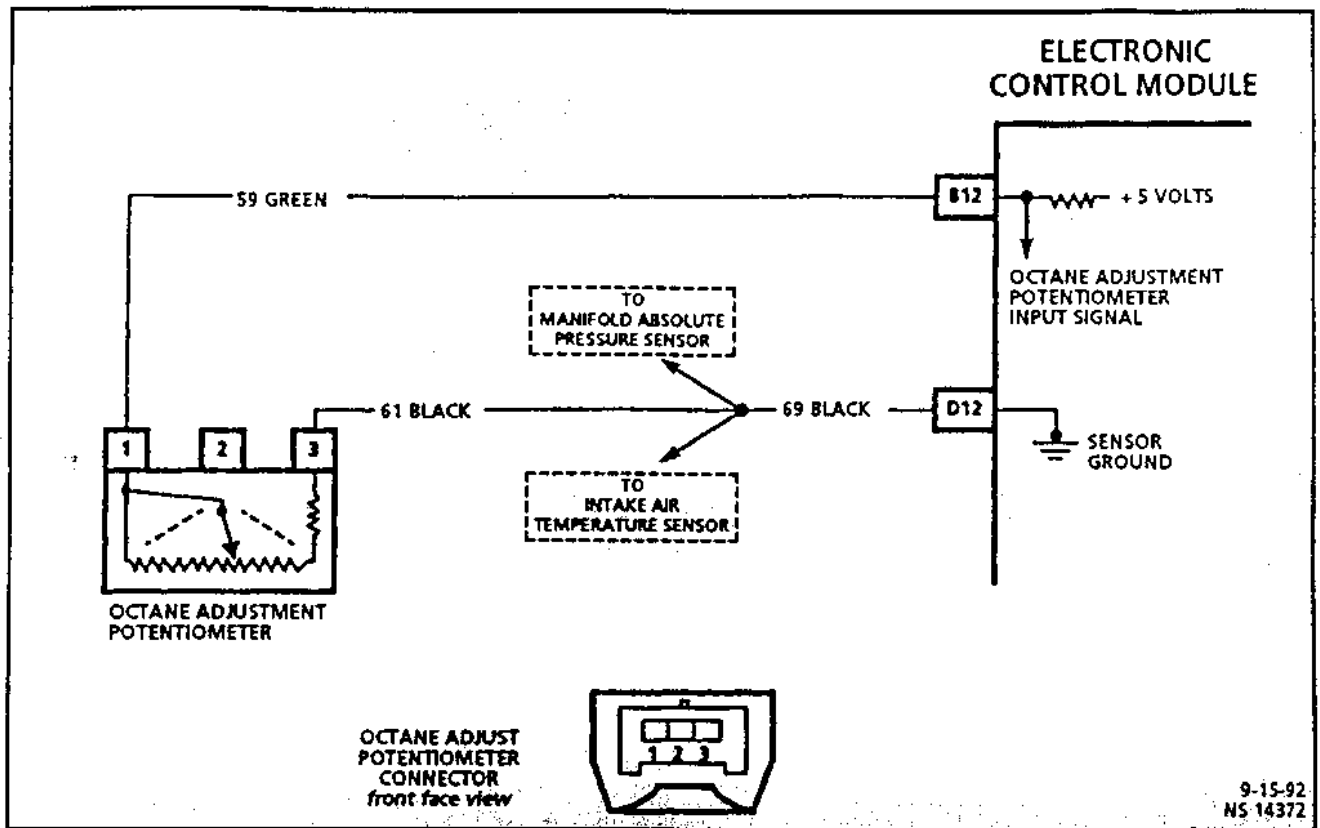

### CODE 54

(Page 1 of 2)

### OCTANE ADJUSTMENT (SIGNAL VOLTAGE TOO HIGH OR TOO LOW) 1.7L THROTTLE BODY INJECTION NIVA

#### Circuit Description:

The octane adjustment potentiometer provides a voltage that changes with an adjustment screw. The voltage is adjustable from about 1 volt to about 4.7 volts. The engine must be running to allow the Tech 1 to read this voltage correctly.

The octane adjustment voltage acts as an ignition timing spark retard which allows for adjustments when low octane fuel produces spark knock.

**Test Description:** Number(s) below refer to circled number(s) on the diagnostic chart.

1. Code 54 will set if:
  - The octane adjustment signal voltage is less than 0.5 volts or greater than 4.9 volts for approximately 2 seconds.
2. With the octane adjust potentiometer disconnected from the electronic control module the Tech 1 should read close to 5 volts.

#### Diagnostic Aids:

An open or short to ground in the octane adjustment circuit wires will result in a Code 54, and/or Code 23, Code 33.

Refer to "Intermittents" in "Symptoms," Section "2.9B."

**CODE 54**  
 (Page 1 of 2)  
**OCTANE ADJUSTMENT**  
**(SIGNAL VOLTAGE TOO HIGH OR TOO LOW)**  
**1.7L THROTTLE BODY INJECTION NIVA**

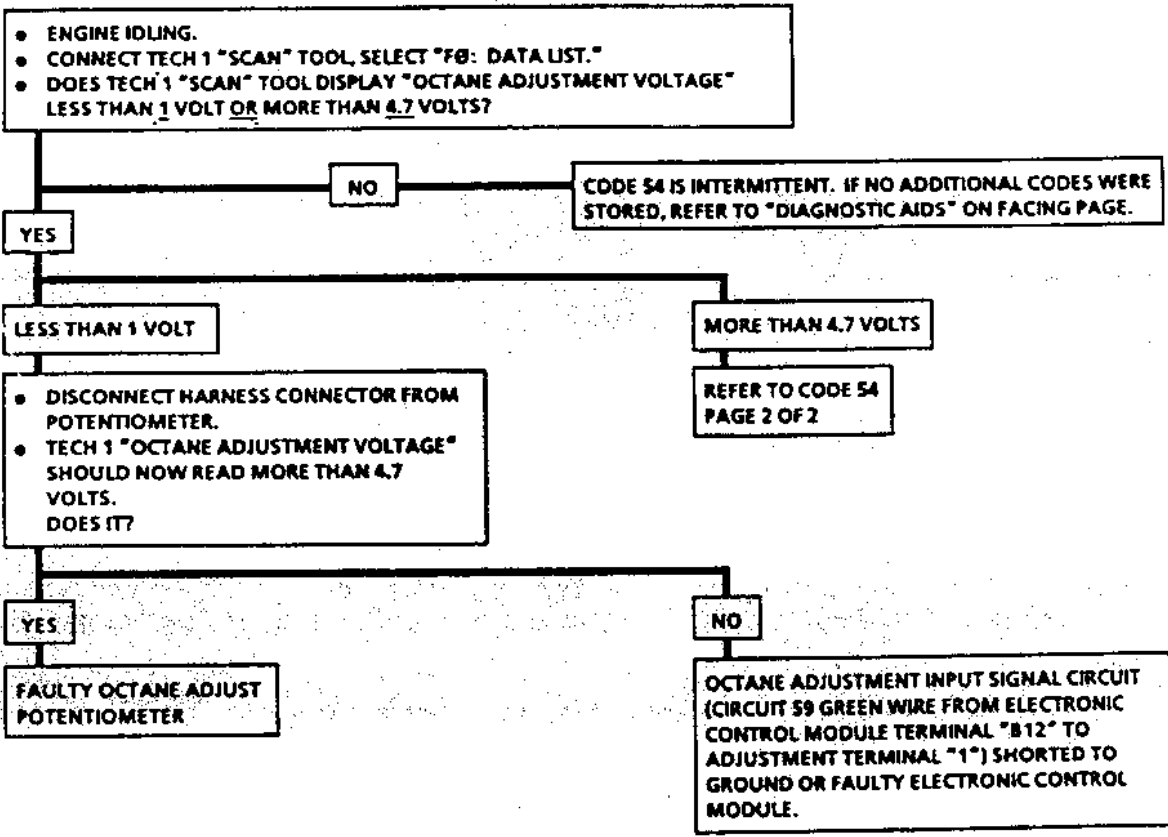

"AFTER REPAIRS," START ENGINE, CLEAR CODES AND CONFIRM NO "CHECK ENGINE" LIGHT.

2-5-93  
 NS 14373



## 2-92 ENGINE MANAGEMENT SYSTEMS 1.7L THROTTLE BODY INJECTION

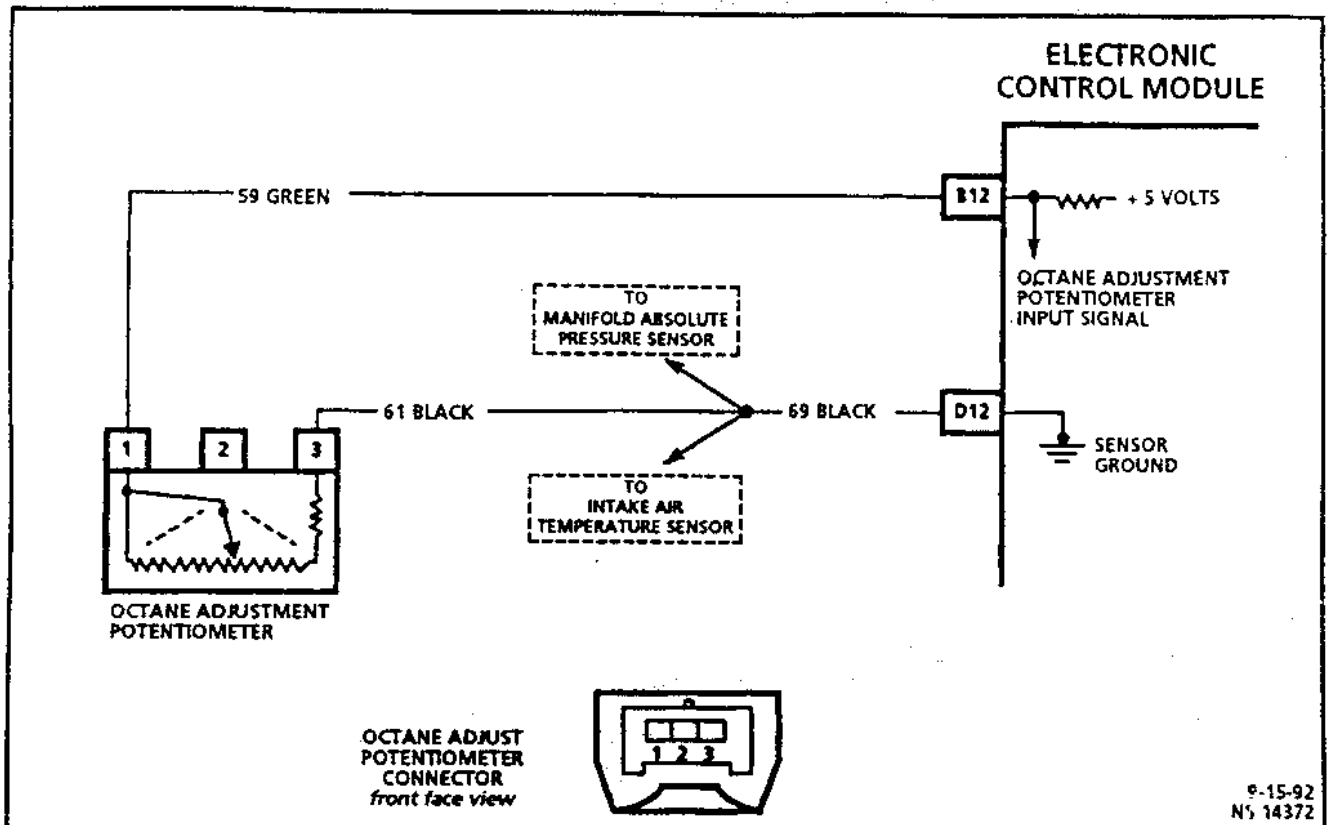

### CODE 54

(Page 2 of 2)

### OCTANE ADJUSTMENT (SIGNAL VOLTAGE TOO HIGH OR TOO LOW) 1.7L THROTTLE BODY INJECTION NIVA

#### Circuit Description:

The octane adjustment potentiometer provides a voltage that changes with an adjustment screw. The voltage is adjustable from about 1 volt to about 4.7 volts. The engine must be running to allow the Tech 1 to read this voltage correctly.

The octane adjustment voltage acts as an ignition timing spark retard ratio trim pot which allows for adjustments when low octane fuel produces spark knock.

**Test Description:** Number(s) below refer to circled number(s) on the diagnostic chart.

3. This step checks for a short to voltage or a potentially bad octane adjust potentiometer.
4. This step checks for an open ground circuit between the electronic control module and octane adjust potentiometer terminal "3".
5. This will determine if there is an open in the input signal wire, faulty connections or a potentially bad electronic control module.

**CODE 54**  
 (Page 2 of 2)  
**OCTANE ADJUSTMENT**  
 (SIGNAL VOLTAGE TOO HIGH OR TOO LOW)  
 1.7L THROTTLE BODY INJECTION NIVA

CONTINUED FROM  
 CODE 54 PAGE 1 OF 2

TECH 1 DISPLAYS "OCTANE ADJUSTMENT VOLTAGE" ABOVE 4.7 VOLTS.

- DISCONNECT HARNESS CONNECTOR FROM OCTANE ADJUST POTENTIOMETER.
- USING CONNECTOR TERMINAL TEST ADAPTER KIT J 35616, CONNECT HARNESS TERMINALS "1" AND "3" TOGETHER.
- ENGINE IDLING.
- TECH 1 SHOULD NOW DISPLAY "OCTANE ADJUSTMENT VOLTAGE" LESS THAN 1 VOLT. DOES IT?

3

NO

4

- REMOVE JUMPER WIRE FROM BETWEEN OCTANE ADJUST POTENTIOMETER HARNESS TERMINALS "1" AND "3".
- USING CONNECTOR TEST ADAPTER KIT J 35616, CONNECT OCTANE ADJUST POTENTIOMETER HARNESS TERMINAL "1" TO GROUND. (CIRCUIT 59 GREEN WIRE.)
- ENGINE IDLING.
- TECH 1 SHOULD NOW DISPLAY "OCTANE ADJUSTMENT VOLTAGE" LESS THAN 1 VOLT. DOES IT?

YES

CHECK FOR SHORT CIRCUIT TO ALTERNATIVE VOLTAGE SOURCE ON INPUT SIGNAL WIRE (CIRCUIT 59 GREEN WIRE BETWEEN ELECTRONIC CONTROL MODULE AND "OCTANE ADJUST POTENTIOMETER HARNESS TERMINAL "1" AND ELECTRONIC CONTROL MODULE TERMINAL "B12"). IF NONE FOUND REPLACE OCTANE ADJUST POTENTIOMETER AND RETEST. SEE SECTION 3.1 FOR REPLACE AND ADJUST PROCEDURE.

NO

5

- AT ELECTRONIC CONTROL MODULE BACKPROBE CONNECTOR "B12" WITH A TEST LIGHT CONNECTED TO GROUND. LEAVE TEST LIGHT IN PLACE WHILE OBSERVING TECH 1 DISPLAY.
- ENGINE IDLING.
- TECH 1 SHOULD NOW DISPLAY "OCTANE ADJUSTMENT VOLTAGE" LESS THAN 1 VOLT. DOES IT?

YES

REPAIR OPEN SENSOR GROUND CIRCUIT (BLACK WIRE) BETWEEN ELECTRONIC CONTROL MODULE TERMINAL "D2" AND OCTANE ADJUST POTENTIOMETER HARNESS CONNECTOR TERMINAL "3".

NO

FAULTY CONNECTIONS OR  
 FAULTY ELECTRONIC CONTROL MODULE.

YES

REPAIR OPEN CIRCUIT IN INPUT SIGNAL WIRE (CIRCUIT 59 GREEN WIRE) BETWEEN TERMINAL "B12" AND OCTANE ADJUST POTENTIOMETER HARNESS TERMINAL "1".

"AFTER REPAIRS," START ENGINE, CLEAR CODES AND CONFIRM NO "CHECK ENGINE" LIGHT.

2-8-93  
 NS 15695

**CODE 55**  
**ELECTRONIC CONTROL**  
**MODULE ERROR**

**FAULTY ELECTRONIC CONTROL MODULE.**  
**REPLACE ELECTRONIC CONTROL MODULE**

**"AFTER REPAIRS," START ENGINE, CLEAR CODES AND CONFIRM NO "CHECK ENGINE" LIGHT.**

5-27-92  
NS 14981

SECTION 2.9B

SYMPTOM CHARTS  
CONTENTS

|   | Page  |
|---|-------|
| Important Preliminary Checks.....                                 | 2-96  |
| Before Starting.....  | 2-96  |
| Intermittents (1 of 2).....                                       | 2-97  |
| Head Start.....   | 2-99  |
| Surges and/or Chuggles.....                                       | 2-101 |
| Lack of Power, Sluggish, or Spongy (1 of 2).....                  | 2-102 |
| Detonation/Spark Knock (1 of 2).....                              | 2-104 |
| Hesitation, Sag, Stumble.....                                     | 2-106 |
| Cuts Out, Misses.....   | 2-107 |
| Poor Fuel Economy.....  | 2-108 |
| Rough, Unstable or Incorrect Idle, Stalling (1 of 2).....         | 2-109 |
| Excessive Exhaust Emissions or Odors.....                         | 2-111 |
| Dieseling, Run-On.....  | 2-112 |
| Backfire.....   | 2-113 |
| Restricted Exhaust System Check Chart B-1.....                    | 2-114 |
| Electronic Control Module Pin Connector "A" - Symptoms Chart..... | 2-115 |
| Electronic Control Module Pin Connector "B" - Symptoms Chart..... | 2-116 |
| Electronic Control Module Pin Connector "C" - Symptoms Chart..... | 2-117 |
| Electronic Control Module Pin Connector "D" - Symptoms Chart..... | 2-118 |

### IMPORTANT PRELIMINARY CHECKS

- Before using this section you should have performed the "Diagnostic Circuit Check."
- Verify the customer complaint, and locate the correct symptom. Check the items indicated under that symptom.
- If the ENGINE CRANKS BUT WILL NOT RUN, use CHART A-3.
- Several of the following symptom procedures call for a careful visual/physical check.

*The importance of this step cannot be stressed too strongly—it can lead to correcting a problem without further checks and can save valuable time.*

### BEFORE STARTING

This check should include:

- Electronic control module grounds for being clean, tight, and in their proper location.
- Vacuum hoses for splits, kinks and proper connections. Check thoroughly for any type of leak or restriction.
- Air leaks at throttle body mounting area and intake manifold sealing surfaces (also check intake manifold Electric Heater's mounting bolts for proper tightness).
- Ignition wires for cracking, hardness, proper routing and carbon tracking.
- Wiring for proper connections, pinches, and cuts.

If wiring harness or connector repair is necessary, refer to "Service Operations," Section "3" for correct procedure.

## INTERMITTENTS

(Page 1 of 2)

**Definition:** Problem may or may not turn "ON" the "Check Engine" light, or store a code.

### PRELIMINARY CHECKS

- Perform the careful visual/physical checks as described at start of "Symptoms," in this section.

### DIAGNOSTIC CODE CHARTS IN "DIAGNOSTIC CHARTS," SECTION "2.9-A"

- DO NOT use the Diagnostic Code Charts in "Diagnostic Charts," Section "2.9-A" for intermittent problems. The fault must be present to locate the problem. If a fault is intermittent, use of diagnostic code charts may result in replacement of good parts.

### FAULTY ELECTRICAL CONNECTIONS OR WIRING

- Most intermittent problems are caused by faulty electrical connections or wiring. Perform a careful check of suspect circuits for:
  - Poor mating of the connector halves, or terminals, not fully seated in the connector body (backed out).
  - Improperly formed or damaged terminals. All connector terminals in problem circuit should be carefully reformed or replaced to insure proper contact tension.
  - Poor terminal to wire connection. This requires removing the terminal from the connector body to check. See "Service Operations" Section "3," "Wiring Harness Service."

### ROAD TEST

- If a visual/physical check does not find the cause of the problem, the vehicle can be driven with a voltmeter connected to a suspected circuit or a Tech 1 "Scan" tool may be used. An abnormal voltage or Tech 1 "Scan" tool reading when the problem occurs indicates the problem may be in that circuit.

The Tech 1 "Scan" tool has a special mode called "snapshot." This snapshot mode can be used to capture electronic control module serial data when a problem occurs, so that the technician can play back the data one event at a time to look for erroneous data when the fault occurred. For more information on the snapshot mode, refer to the Tech 1 operator's manual.

## INTERMITTENTS

(Page 2 of 2)

Definition: Problem may or may not turn "ON" the "Check Engine" light, or store a code.

### INTERMITTENT "CHECK ENGINE" LIGHT

- As intermittent "Check Engine" light, and No Diagnostic Codes, may be caused by:
  - Electrical system interference caused by a defective relay, electronic control module driven solenoid, or switch. They can cause a sharp electrical surge. Normally, the problem will occur when the faulty component is operated.
  - Improper installation of electrical options, such as lights, 2-way radios, etc.
  - Electronic spark timing wires not properly routed away from spark plug wires, ignition system components and generator.
  - Ignition secondary shorted to ground.
  - "Check Engine" light circuit or diagnostic "test" terminal circuit intermittently shorted to ground.
  - Electronic control module grounds not clean, tight, and in their proper location. These ground wires secure to the engine block on the direct ignition system bracket uppermost bolt. This bolt was previously used to retain the distributor on a carbureted engine.

### LOSS OF DIAGNOSTIC CODE MEMORY

- To check, disconnect throttle position sensor and idle engine until "Check Engine" light comes "ON." Code 22 should be stored and kept in memory, when the ignition is turned "OFF" longer than 10 seconds. If Code 22 is not stored, the electronic control module is faulty.

## HARD START

(Page 1 of 2)

**Definition:** Engine cranks OK, but does not start for a long time. Does eventually run, or may start but immediately dies.

### PRELIMINARY CHECKS

- Perform the careful visual/physical checks as described at start of "Symptoms," in this section.
- Make sure the driver is using the correct starting procedure. This includes depressing and holding the clutch pedal down while cranking to start. When starting the engine at very cold temperatures of below  $-10^{\circ}\text{C}$ , the accelerator pedal should be held down 1/4 of the way while cranking to start, as well as depressing the clutch pedal.

### SENSORS

- **CHECK:** Coolant temperature sensor—Using a Tech 1 "Scan" tool, compare coolant temperature with ambient temperature on a cold engine.
  - If coolant temperature reading is  $2^{\circ}\text{C}$  greater than or less than ambient air temperature on a cold engine, check for high resistance in coolant sensor circuit or sensor itself. Compare resistance value to the "Diagnostic Aids" chart on the Code 14 or Code 15 chart.
- **CHECK:** Throttle position sensor—use CHART C-1H.
- **CHECK:** Manifold absolute pressure sensor—use CHART C-1D.

### FUEL SYSTEM

- **CHECK:** In-line fuel filter. Replace if dirty or plugged.
- **CHECK:** For poor quality fuel.
- **CHECK:** Fuel pressure, use CHART A-7.
- **CHECK:** For contaminated fuel.
- **CHECK:** Fuel system relay—Connect test light between fuel pump "test" terminal and ground. Test light should be "ON" for 2 seconds following ignition "ON," after ignition switch has been "OFF" for at least 10 seconds. If not OK, use CHART A-5.
- **CHECK:** Operation of intake manifold electrical heater (see: CHART C-9).

### IGNITION SYSTEM

- **CHECK:** Ignition system for:
  - Proper ignition voltage output with spark tester J 26792 (ST-125).
  - Spark plugs, wet plugs, cracks, wear, improper gap, burned electrodes or heavy deposits.
  - Crankshaft sensor resistance and connections.
  - Spark plug leads/wires for excessive resistance.
  - Bare and shorted wires.
  - Loose ignition coil connections.
- **CHECK:** Electronic spark timing output circuit for short to ground.



## HARD START

(Page 2 of 2)

**Definition:** Engine cranks OK, but does not start for a long time. Does eventually run, or may start but immediately dies.

### ADDITIONAL CHECKS

- **CHECK:** Idle air control operation, use CHART C-2C.
- **CHECK:** For correct engine calibrator (see "Service Bulletins").

### CRANKING AND CHARGING SYSTEMS, AND CONDITION OF BATTERY

- **CHECK:** For low cranking speeds that can cause difficult starting. Use the Tech 1 "Scan" tool in the "Miscellaneous Tests" - "Crank Tests" mode to monitor cranking speed information.

# **TURBONutter**

Lada Niva 4x4  
Service Manual  
Fuel Injection

This manual and a host of other wonderful Lada Niva documentation is available free of charge at:

<http://www.turbo-nutter.com>

You can do anything you like with this manual except sell it or otherwise make money from it.

While I can't stop you sticking it on your own website I would much prefer you linked to its original location on turbo-nutter.com

You use the information contained with this manual at you own risk. If you're not sure how to do something either don't do it or ask someone who knows about such things. The font of all Lada knowledge can be found at:

<http://www.lada.co.uk/forum>

For Lada parts, advice and general all round Lada wonderfulness these blokes aren't bad:

Lada UK Ltd  
Askew Rigg  
Troutbeck  
Penrith, Cumbria  
CA11 0SZ  
United Kingdom

T: +44 (0) 17 6877 9794  
F: +44 (0) 17 6877 9197  
E: [alan@lada.co.uk](mailto:alan@lada.co.uk)  
W: <http://www.lada.co.uk>

Lada Parts Australia P/L  
42 Aerodrome Road  
Caboolture  
Queensland  
4510  
Australia

T: +61 7 5495 5100  
F: +61 7 5495 5152  
E: [andy@ladaparts.com](mailto:andy@ladaparts.com)  
W: <http://www.ladaparts.com>

### SURGES AND/OR CHUGGLES

**Definition:** Engine power variation, under steady throttle or cruise. Feels like the vehicle speeds up and slows down, with no change in the accelerator pedal.

#### PRELIMINARY CHECKS

- Perform the careful visual/physical checks as described at start of "Symptoms," in this section.
- Be sure driver understands air conditioning compressor operation in owner's manual.
- Use a Tech 1 "Scan" tool to make sure reading of vehicle speed sensor matches vehicle speedometer.

#### FUEL SYSTEM

- **CHECK:** Fuel pressure while condition exists, use CHART A-7.
- **CHECK:** In-line fuel filter. Replace if dirty or plugged.

#### IGNITION SYSTEM

- **CHECK:** For proper ignition system voltage output using spark tester J 26792 (ST-125).
- **CHECK:** Spark plugs. Remove spark plugs, check for wet plugs, cracks, wear, improper gap, burned electrodes, or heavy deposits. Repair or replace as necessary.
- **CHECK:** For misfire under load. Use CHART C-4C.

#### ADDITIONAL CHECKS

- **CHECK:** Electronic control module grounds for being clean, tight, and in their proper locations. These ground wires secure to the engine block on the direct ignition system bracket uppermost bolt. This bolt was previously used to retain the distributor on a carbureted engine.
- **CHECK:** Alternator output voltage. Repair if less than 9 or more than 16.9 volts.
- **CHECK:** Vacuum lines for kinks or leaks.

**LACK OF POWER, SLUGGISH, OR SPONGY**

(Page 1 of 2)

**Definition:** Engine delivers less than expected power. Little or no increase in speed, when accelerator pedal is pushed down part way.

**PRELIMINARY CHECKS**

- Perform the careful visual/physical checks as described at start of "Symptoms," in this section.
- Compare customer's vehicle to similar unit. Make sure the customer has an actual problem.
- Remove air filter and check air filter for dirt, or for being plugged, replace as necessary.

**FUEL SYSTEM**

- **CHECK:** For contaminated fuel.
- **CHECK:** For restricted fuel filter, or improper fuel pressure, use CHART A-7.

**IGNITION SYSTEM**

- **CHECK:** Proper ignition system voltage output with spark tester J 26792 (ST-125).
- **CHECK:** Ignition timing.
- **CHECK:** Proper operation of electronic spark timing.

**EXHAUST SYSTEM**

- **CHECK:** Exhaust system for possible restriction: Use CHART B-1.

**SENSORS**

- **CHECK:** Manifold absolute pressure sensor. Use CHART C-1D. Vacuum hose between engine and manifold absolute pressure sensor for kinks or leaks.

## LACK OF POWER, SLUGGISH, OR SPONGY

(Page 2 of 2)

**Definition:** Engine delivers less than expected power. Little or no increase in speed, when accelerator pedal is pushed down part way.

### ENGINE MECHANICAL

- **CHECK:** Engine compression. Refer to Engine Manual.
- **CHECK:** Engine valve timing. Refer to Engine Manual.
- **CHECK:** Engine for proper or worn camshaft. Refer to Engine Manual.

### ADDITIONAL CHECKS

- **CHECK:** Electronic control module grounds for being clean, tight, and in their proper location. These ground wires secure to the engine block on the direct ignition system bracket uppermost bolt.
- **CHECK:** Air conditioning operation. Air conditioning clutch should cut out at wide open throttle.
- **CHECK:** Alternator output voltage. Repair if less than 9 or more than 16.9 volts.

## DETONATION/SPARK KNOCK

(Page 1 of 2)

**Definition:** A mild to severe ping, usually worse under acceleration. The engine makes sharp metallic knocks that change with throttle opening.

### PRELIMINARY CHECKS

- Perform the careful physical/visual checks as described at start of "Symptoms," in this section.
- Make sure the customer has an actual problem.
- Remove air filter and check air filter for dirt, or for being plugged, replace as necessary.

### COOLING SYSTEM

- **CHECK:** For obvious overheating problems.
- **CHECK:** Low engine coolant.
- **CHECK:** Loose water pump belt.
- **CHECK:** Restricted air flow to radiator, or restricted water flow thru radiator.
- **CHECK:** Faulty or incorrect thermostat.
- **CHECK:** Correct coolant solution.

### SENSOR

- **CHECK:** Coolant temperature sensor, which may have shifted in value. Compare coolant temperature sensor resistance to the "Diagnostic Aids" chart on Code 14 or Code 15 chart.

### FUEL SYSTEM

- **CHECK:** Fuel pressure, use CHART A-7.
- **CHECK:** For poor fuel quality, proper octane rating.

**NOTICE:** If Tech 1 "Scan" tool readings are normal (see TECH 1 "SCAN" TOOL TYPICAL DATA VALUE list) and there are no engine mechanical faults, fill fuel tank with a fresh and proper fuel for vehicle and evaluate vehicle performance.

### OCTANE ADJUSTMENT POTENTIOMETER

- As built at the factory this adjustment was initially set for premium octane fuel. If low octane fuel is to be used on a regular basis, it is advisable to readjust the octane adjustment potentiometer. Use CHART C-15.

### THERMOSTATIC AIR CLEANER

- Ensure that the thermostatic air cleaner functions properly. Check that the temperature actuated damper moves away from "HOT AIR" position after the engine is fully warmed up. Use the Tech 1 "Scan" tool to observe intake air temperature after the engine is fully warmed up. At road speeds the intake air temperature should be close to ambient air temperature.

## DETONATION/SPARK KNOCK

(Page 2 of 2)

**Definition:** A mild to severe ping, usually worse under acceleration. The engine makes sharp metallic knocks that change with throttle opening.

### IGNITION SYSTEM

- **CHECK:** Spark plugs for proper heat range.

### ENGINE MECHANICAL

- **CHECK:** For carbon buildup.
- **CHECK:** For incorrect basic engine parts such as cam, heads, pistons, etc.
- **CHECK:** For excessive oil entering combustion chamber.

### ADDITIONAL CHECKS

- **CHECK:** For correct engine calibrator (see Service Bulletins).
- **CHECK:** For intake manifold electric heater should be "OFF" with the engine fully warmed up. Use Tech 1 to display "MANIFOLD HEATER" "ON/OFF" status.

### HESITATION, SAG, STUMBLE

**Definition:** Momentary lack of response as the accelerator is pushed down. Can occur at all vehicle speeds. Usually most severe when first trying to make the vehicle move, as from a stop sign. May cause the engine to stall if severe enough.

#### PRELIMINARY CHECKS

- Perform the careful visual/physical checks as described at start of "Symptoms," in this section.

#### SENSORS

- **CHECK:** Throttle position sensor. Use CHART C-1H.
- **CHECK:** Manifold absolute pressure sensor response and accuracy. Use CHART C-1D.
- **CHECK:** For kinked or leaking vacuum hose between engine and manifold absolute pressure sensor.

#### IGNITION SYSTEM

- **CHECK:** Spark plug wires for being faulty.
- **CHECK:** Spark plugs for being fouled.
- **CHECK:** Open ignition system ground, reference low circuit.

#### EVAPORATIVE EMISSIONS

- **CHECK:** Evaporative emissions storage canister system. Use CHART C-3.

#### FUEL SYSTEM

- **CHECK:** For restricted fuel filter or improper fuel pressure. Use CHART A-7.

#### ADDITIONAL CHECKS

- **CHECK:** For correct engine calibrator (see Service Bulletins).
- **CHECK:** Alternator output voltage. Repair, if less than 9 or more than 16.9 volts.



### CUTS OUT, MISSES

**Definition:** Steady pulsation or jerking that follows engine speed, usually more pronounced as engine load increases. The exhaust has a steady spitting sound at idle or low speed.

#### PRELIMINARY CHECKS

- Perform the careful visual/physical checks as described at start of "Symptoms," in this section.

#### IGNITION SYSTEM

- **CHECK:** For cylinder miss by:
  1. Start engine, allow engine to stabilize then disconnect idle air control motor. Remove one spark plug wire at a time, using insulated pliers.
  2. If there is a revolutions per minute drop, on all cylinders (equal to within 50 revolutions per minute), go to "Rough, Unstable Or Incorrect Idle, Stalling" symptom. Reconnect idle air control motor.
  3. If there is no revolutions per minute drop on one or more cylinders, or excessive variation in drop, check for spark, on the suspected cylinder(s) with J 26792 (ST-125) Spark Tester. If no spark, use CHART C-4. If there is spark, remove spark plug(s) in these cylinder(s) and check for:
    - Insulation Cracks
    - Wear
    - Improper Gap
    - Burned Electrodes
    - Heavy Deposits
- **CHECK:** For excessive spark plug wire resistance.

**NOTICE:** If the previous checks did not find the problem:

- Visually inspect ignition system for moisture, dust, cracks, burns, etc. With engine running spray plug wires with fine water mist to check for shorts.

#### FUEL SYSTEM

- **CHECK:** For contaminated fuel or restricted fuel filter or incorrect fuel pressure. Use CHART A-7.

#### ENGINE MECHANICAL

- **CHECK:** For proper valve timing. Remove rocker cover. Check for worn rocker arms, broken or weak valve springs, worn camshaft lobes. Repair as necessary. Refer to Engine Manual.
- **CHECK:** Low compression. Perform compression check. Refer to Engine Manual.
- **CHECK:** Intake and exhaust manifold passages for casting flash.

### POOR FUEL ECONOMY

**Definition:** Fuel economy, as measured by an actual road test, is noticeably lower than expected. Also, economy is noticeably lower than it was on this vehicle at one time, as previously shown by an actual road test.

#### PRELIMINARY CHECKS

- Perform the careful visual/physical checks as described at start of "Symptoms," in this section.
- Check air cleaner element (filter) for dirt or being plugged.
- Visually (physically) check: Vacuum hoses for splits, kinks, and proper connections.
- Perform "Diagnostic Circuit Check."
  - Is air conditioning "ON" full time?
  - Are tires at correct pressure?
  - Are excessively heavy loads being carried?
  - Is acceleration too much, too often?

**NOTICE:** Suggest owner fill fuel tank and recheck fuel economy.

#### IGNITION SYSTEM

- **CHECK:** Spark plugs. Remove spark plugs, check for wet plugs, cracks, wear, improper gap, burned electrodes, or heavy deposits. Repair or replace as necessary.
- **CHECK:** Ignition wires for cracking, hardness, and proper connections.

#### FUEL SYSTEM

- **CHECK:** Fuel pressure, use CHART A-7.

#### COOLING SYSTEM

- **CHECK:** Engine coolant level.
- **CHECK:** Engine thermostat for faulty part (always open) or for wrong heat range. Observe Tech 1 "Coolant Temp" with engine fully warm at road speed.

#### ADDITIONAL CHECKS

- **CHECK:** For correct engine calibrator installed in electronic control module. Observe Tech 1 "Calibration ID."
- **CHECK:** For proper calibration of speedometer.
- **CHECK:** For dragging brakes.

#### OCTANE ADJUSTMENT POTENTIOMETER

If premium octane fuel is being used, use Tech 1 to observe "Octane Adjust." With premium octane fuel the "Octane Adjust" value displayed on Tech 1 should be 0°. Use CHART C-15.

#### SENSORS

- **CHECK:** Coolant temperature sensor or air temperature sensor which may have shifted in value. Compare coolant temperature sensor resistance to the "Diagnostic Aids" chart on Code 14 or Code 15 chart.
- **CHECK:** Manifold absolute pressure sensor. Use CHART C-1D.

**ROUGH, UNSTABLE OR INCORRECT IDLE, STALLING**

(Page 1 of 2)

**Definition:** The engine runs unevenly at idle. If bad enough, the vehicle may shake. Also, the engine idle speed may vary (called "hunting"). Either condition may be severe enough to cause stalling. Engine idles at incorrect speed.

**PRELIMINARY CHECKS**

- Perform the careful visual/physical checks as described at start of "Symptoms," in this section.

**SENSORS**

- **CHECK:** Throttle position sensor - Use CHART C-1H.
- **CHECK:** Coolant temperature sensor - Using a Tech 1 "Scan" tool, compare coolant temperature with ambient temperature on a cold engine.
  - If coolant temperature reading 2°C greater than or less than ambient air temperature. Check for high resistance in coolant temperature sensor circuit or sensor itself. Compare resistance value to "Diagnostic Aids" on Code 14 and Code 15 chart.
- **CHECK:** Manifold absolute pressure sensor response and accuracy, manifold absolute pressure sensor vacuum hose, use CHART C-1D.

**FUEL SYSTEM**

- **CHECK:** Evaporative Emission Control System. Use CHART C-3.
- **CHECK:** Injector for leaking. Energize fuel system by either turning the ignition key to the "ON" position which will pressurize the fuel system for 2 seconds or by applying battery voltage to the fuel pump test terminal. (Assembly line data link terminal "G".) Applying battery voltage will force the fuel pump to run until the battery voltage is removed. Visually check injector and throttle body injection assembly for fuel leakage. Refer to CHART A-7 "Fuel System Diagnosis."
- **CHECK:** Fuel pressure, use CHART A-7.

**IGNITION SYSTEM**

- **CHECK:** Ignition system for:
  - Proper ignition voltage output with spark tester J 26792 (ST-125).
  - Spark plugs, wet plugs, cracks, wear, improper gap, burned electrodes or heavy deposits.
  - Spark plug leads/wires for excessive resistance.
  - Bare and shorted wires.
  - Crankshaft sensor resistance and connections.
  - Loose ignition coil connections.
- **CHECK:** For misfire at idle. Use CHART C-4B.

## ROUGH, UNSTABLE OR INCORRECT IDLE, STALLING

(Page 2 of 2)

**Definition:** The engine runs unevenly at idle. If bad enough, the vehicle may shake. Also, the engine idle speed may vary (called "hunting"). Either condition may be severe enough to cause stalling. Engine idles at incorrect speed.

### ADDITIONAL CHECKS

- **CHECK:** Vacuum leaks can cause higher than normal idle speeds.
- **CHECK:** Idle air control operation, use CHART C-2C.
- **CHECK:** Electronic control module grounds for clean, tight, and in their proper location. These ground wires secure to the engine block on the direct ignition system bracket uppermost bolt. This bolt was previously used to retain the distributor on a carbureted engine.

**NOTICE:** Use Tech 1 "Scan" tool to determine if electronic control module is receiving air conditioning request signal. If problem exists only with air conditioning "ON," check air conditioning system for overcharge or undercharge of R12 refrigerant system.

- **CHECK:** Battery cables and ground straps should be clean and secure. Erratic voltage will cause idle air control to change its position, resulting in poor idle quality.
- **CHECK:** Idle air control valve will not move, if system voltage is below 9 or greater than 16.9 volts.
- **CHECK:** Crankcase ventilation system for proper operation (see: CHART C-13).

### ENGINE MECHANICAL

- **CHECK:** For broken motor mounts.
- **CHECK:** Perform a compression check. Refer to Engine Manual.

**EXCESSIVE EXHAUST EMISSIONS OR ODORS**

**Definition:** Vehicle fails an emission test. Excessive odors do not necessarily indicate excessive emissions.

**PRELIMINARY CHECKS**

- Perform "Diagnostic Circuit Check."
- If EMISSION TEST shows excessive carbon monoxide and hydro carbons check items which cause vehicle to run RICH. Make sure engine is at normal operating temperature.
- If EMISSION TEST shows excessive oxides of nitrogen check items which cause car to run LEAN or too hot.

**SENSORS**

- **CHECK:** Manifold absolute pressure sensor - Use CHART C-1D to check the manifold absolute pressure sensor.

**NOTICE:** If the Tech 1 "Scan" tool indicates a very high coolant temperature and the system is running LEAN:

Check the cooling system and cooling fan for proper operation.

**FUEL SYSTEM**

- **CHECK:** For proper fuel cap.
- **CHECK:** Fuel pressure, use CHART A-7.

**NOTICE:** If test shows excessive oxides of nitrogen, check items which cause vehicle to run LEAN or too hot.

- **CHECK:** Canister for fuel loading. Refer to CHART C-3.

**IGNITION SYSTEM**

- **CHECK:** Ignition system for:
  - Proper ignition voltage output with spark tester J 26792 (ST-125).
  - Spark plugs, wet plugs, cracks, wear, improper gap, burned electrodes or heavy deposits.
  - Spark plug leads/wires for excessive resistance.
  - Bare and shorted wires.
  - Crankshaft sensor resistance and connections.
  - Loose ignition coil connections.

**ADDITIONAL CHECKS**

- **CHECK:** For vacuum leaks.
- **CHECK:** Carbon build-up in combustion chambers.
- **CHECK:** Crankcase ventilation system for proper operation (see: CHART C-13).

**DIESELING, RUN-ON**

**Definition:** Engine continues to run after key is turned "off," but runs very roughly. If engine runs smoothly, check ignition switch and adjustment, and short to voltage on ignition switch voltage input circuit.

**PRELIMINARY CHECKS**

- Perform the careful visual/physical checks as described at start of "Symptoms." in this section.

**FUEL SYSTEM**

- **CHECK:** Injector for leaking. Energize fuel system by either turning the ignition key to the "ON" position which will pressurize the fuel system for 2 seconds or by applying battery voltage to the fuel pump test terminal. (Assembly line data link terminal "G".) Applying battery voltage will force the fuel pump to run until the battery voltage is removed. Visually check injector and throttle body injection assembly for fuel leakage. Refer to CHART A-7 "Fuel System Diagnosis."

**BACKFIRE**

**Definition:** Fuel ignites in intake manifold, or in exhaust system, making a loud popping noise.

**PRELIMINARY CHECKS**

- Perform the careful visual/physical checks as described at start of "Symptoms," in this section.

**IGNITION SYSTEM**

- **CHECK:** Proper ignition coil output voltage with spark tester J 26792 (ST-125).
- **CHECK:** Spark plugs. Remove spark plugs, check for wet plugs, cracks, wear, improper gap, burned electrodes, or heavy deposits, repair or replace as necessary.
- **CHECK:** For defective insulation on the spark plug wires or boots. This would allow high voltage arching to engine parts, mostly noticeable during acceleration.
- **CHECK:** For excessive spark plug wire resistance.
- **CHECK:** For crossfire between spark plug wires (proper routing of plug wires). Refer to Engine Manual.

**ENGINE MECHANICAL**

- **CHECK:** Perform a compression check. Refer to Engine Manual.
- **CHECK:** Valve timing. Remove rocker cover. Check for worn rocker arms, broken or weak valve springs, worn camshaft lobes or misadjusted valve clearances.
- **CHECK:** Intake manifold gasket for vacuum leaks.
- **CHECK:** Intake and exhaust manifolds for casting flash.

## CHART B-1

### RESTRICTED EXHAUST SYSTEM CHECK

#### CHECK AT OXYGEN SENSOR:

1. Carefully remove oxygen sensor.
2. Install exhaust backpressure tester (BT-8515-V) or equivalent in place of oxygen sensor (see illustration).
3. After completing test described below, be sure to coat threads of oxygen sensor with anti-seize compound or equivalent prior to re-installation.

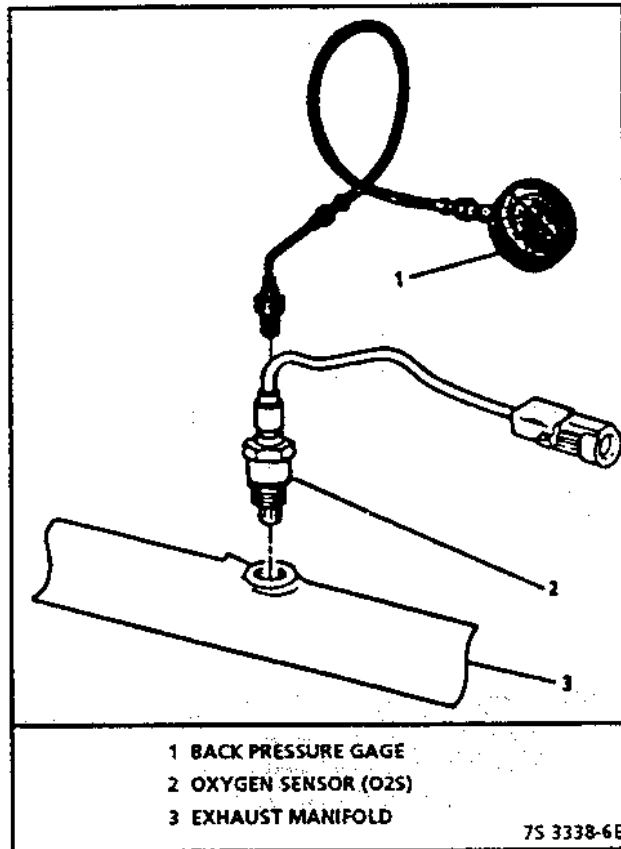

#### DIAGNOSIS:

1. With the engine at normal operating temperature and running at 2500 revolutions per minute, observe the exhaust system backpressure reading on the gauge.
2. If the pressure exceeds 1 1/4 psi (8.62 kPa), a restricted exhaust system is indicated.
3. Inspect the entire exhaust system for a collapsed pipe, heat distress, or possible internal muffler failure.
4. If there are no obvious reasons for the excessive backpressure, a restricted catalytic converter should be suspected, and replaced using current recommended procedures.

4-26-93  
NS 14689



## ELECTRONIC CONTROL MODULE PIN CONNECTOR "A" SYMPTOMS CHART 24-PIN A-B CONNECTOR

This electronic control module symptoms chart is for use with a digital voltmeter to further aid in diagnosis. The voltages you get may vary due to low battery charge or other reasons, but they should be very close.

**BACKPROBE CONNECTORS ONLY!**

**THE FOLLOWING CONDITIONS MUST BE MET BEFORE TESTING:**

- Engine at operating temperature    ● Engine idling (For "Engine Run" column)
- Diagnostic "test" terminal not grounded    ● Tech 1 "Scan" tool not installed
- Air conditioning "OFF"
- Digital voltmeter "-" (negative) lead connected to a good clean ground point.

| PIN FUNCTION  | WIRE COLOR       | COMPONENT/<br>CONNECTOR<br>CAVITY   | NORMAL VOLTAGE |                | CODES<br>AFFECT. | POSSIBLE SYMPTOMS FROM<br>FAULTY CIRCUIT   |
|---|------------------|---|----------------|----------------|------------------|--|
|   |                  |   | IGN<br>"ON"    | ENG.<br>RUN    |                  |  |
| A1 FUEL SYSTEM<br>RELAY CONTROL   | GREEN/<br>WHITE  | FUEL PUMP<br>RELAY "2"  | (1) 0**        | B+             | NONE             | NO START, SEE CHART A-7. PUMP RUNS<br>ALL THE TIME (11)  |
| A2 NO CONNECTION  |                  |   |                |                |                  |  |
| A3 PULSE WIDTH<br>MODULATOR<br>CANISTER CONTROL                         | GREEN/<br>YELLOW | CANISTER "B"  | 0*             | 0*             | NONE             | FUEL LOSS OR FUEL VAPOR ODOR, POOR<br>IDLE, STALLING, POOR DRIVEABILITY.   |
| A4 NO CONNECTION  |                  |   |                |                |                  |  |
| A5 "CHECK ENGINE"<br>LIGHT CONTROL                                      | BLACK/<br>WHITE  | INSTRUMENT<br>PANEL CLUSTER   | 0*             | B+             | NONE             | NO CHECK ENGINE LIGHT (8), LIGHT "ON"<br>ALL THE TIME, DOES NOT FLASH CODES<br>(10). SEE "DIAGNOSTIC CIRCUIT CHECK."                               |
| A6 IGNITION SWITCH<br>VOLTAGE INPUT<br>SIGNAL                           | PINK/<br>BLACK   | DIRECT IGNITION<br>SYSTEM MODULE<br>2 CONNECTOR<br>PIN "B" AND 6<br>CONNECTOR PIN "B" | B+             | B+             | 53               | NO START, NO CHECK ENGINE LIGHT, NO<br>SERIAL DATA (8), FUSE BLOWN (10), SEE<br>"DIAGNOSTIC CIRCUIT CHECK."<br>ENGINE WILL NOT STOP RUNNING. (11). |
| A7 NO CONNECTION  |                  |   |                |                |                  |  |
| A8 SERIAL DATA<br>COMMUNICATIONS  | ORANGE           | ASSEMBLY LINE<br>DATA LINK "M"  | 2-5<br>VARYING | 2-5<br>VARYING | NONE             | NO ASSEMBLY LINE DATA LINK OR WILL<br>NOT FLASH CODE 12 (9).<br>SEE "DIAGNOSTIC CIRCUIT CHECK."  |
| A9 DIAGNOSTIC<br>"TEST" TERMINAL<br>INPUT SIGNAL                        | BLACK/<br>WHITE  | ASSEMBLY LINE<br>DATA LINK "B"  | 5              | 5              | NONE             | NO ASSEMBLY LINE DATA LINK OR WILL<br>NOT FLASH CODE 12 (8).<br>FLASHES CODES, HIGH-SPEED FAN IS ON.<br>(10). SEE "DIAGNOSTIC CIRCUIT CHECK."      |
| A10 VEHICLE SPEED<br>INPUT SIGNAL                                       | GREEN            | VEHICLE SPEED<br>SENSOR "2"   | VARIES         | VARIES         | 24               | ENGINE MAY STALL AT COASTDOWN,<br>TECH 1 SCAN VEHICLE SPEED DOES NOT<br>MATCH SPEEDOMETER (9, 11).   |
| A11 COOLANT<br>TEMPERATURE<br>AND THROTTLE<br>POSITION SENSOR<br>GROUND | PINK/<br>BLACK   | COOLANT<br>TEMPERATURE<br>SENSOR "A"<br>THROTTLE POSITION<br>SENSOR "B"               | 0**            | 0**            | 15<br>21 (8)     | HIGH IDLE, ROUGH IDLE, HARD TO START,<br>POOR PERFORMANCE, EXCESSIVE<br>EXHAUST EMISSIONS (8).   |
| A12 ELECTRONIC<br>CONTROL MODULE<br>GROUND                              | BROWN            | ASSEMBLY LINE<br>DATA LINK "A"  | 0**            | 0**            | NONE             | "A12" AND "O1" OPEN - NO START (8).<br>POOR GROUNDS - POOR PERFORMANCE.<br>SEE "DIAGNOSTIC CIRCUIT CHECK."   |

- 1 Battery voltage for first two seconds, after ignition is turned "ON" without cranking the engine. When vehicle is stopped, voltage will be either less than 1 volt or greater than 10 volts; depending upon position of drive wheels. When vehicle is moving, voltage will vary depending upon vehicle speed.
- 2 Varies with temperature.

- 4 Varies. With ignition "ON" reads barometric pressure. With engine running, reads engine load.
- 5 Voltage will vary with engine revolutions per minute.
- 6 Depending on octane adjust potentiometer trim.
- 7 Battery voltage (B+) with engine warm.
- 8 Open.

- 9 Open/grounded circuit.
- 10 Grounded circuit.
- 11 Short to +12 volts.
- \* Less than 0.50 volts.
- \*\* Less than 0.10 volts.
- \*\*\*\* Air Conditioning Vehicles Only
- B+ Should equal battery voltage.

9-17-92  
NS 14374

## 2-116 ENGINE MANAGEMENT SYSTEMS 1.7L THROTTLE BODY INJECTION

### ELECTRONIC CONTROL MODULE PIN CONNECTOR "B" SYMPTOMS CHART 24-PIN A-B CONNECTOR

This electronic control module symptoms chart is for use with a digital voltmeter to further aid in diagnosis. The voltages you get may vary due to low battery charge or other reasons, but they should be very close.

**BACKPROBE CONNECTORS ONLY!**

**THE FOLLOWING CONDITIONS MUST BE MET BEFORE TESTING:**

- Engine at operating temperature
- Engine idling (For "Engine Run" column)
- Diagnostic "test" terminal not grounded
- Tech 1 "Scan" tool not installed
- Air conditioning "OFF"
- Digital voltmeter "—" (negative) lead connected to a good clean ground point.

| PIN FUNCTION                             | WIRE COLOR    | COMPONENT/<br>CONNECTOR/<br>CAVITY | NORMAL VOLTAGE      |              | CODES AFFECT. | POSSIBLE SYMPTOMS FROM FAULTY CIRCUIT   |
|--|---------------|------------------------------------|---------------------|--------------|---------------|---|
|  |               |                                    | IGN. "ON"           | ENG. RUNNING |               |   |
| B1 BATTERY + (POWER SUPPLY)              | RED           | ELECTRONIC CONTROL MODULE "B1"     | B+                  | B+           | NONE          | FUSIBLE LINK BLOWN, NO START (10), IF "C16" AND "B1" OPEN, NO START SEE "DIAGNOSTIC CIRCUIT CHECK."           |
| B2 NO CONNECTION                         |               |                                    |                     |              |               |   |
| B3 CRANKSHAFT REFERENCE LOW              | BLACK/ RED    | 6-PIN CONNECTOR "F"                | 0**                 | 0**          | NONE          | MAY HAVE POOR PERFORMANCE, FLICKERING CHECK ENGINE LIGHT (9), NO START, POSSIBLE IGNITION MODULE DAMAGE (11). |
| B4 NO CONNECTION                         |               |                                    |                     |              |               |   |
| B5 CRANKSHAFT REFERENCE INPUT SIGNAL     | PURPLE/ WHITE | 6-PIN CONNECTOR "E"                | 0*                  | 1.0 (6)      | NONE          | NO START (9). SEE "DIAGNOSTIC CIRCUIT CHECK."   |
| B6 NO CONNECTION                         |               |                                    |                     |              |               |   |
| B7 NO CONNECTION                         |               |                                    |                     |              |               |   |
| B8 AIR CONDITIONING REQUEST INPUT SIGNAL | GREEN         | HIGH-SIDE HIGH-PRESSURE SWITCH     | "OFF" 0*<br>"ON" 0* | 0*<br>B+     | NONE          | NO AIR CONDITIONING (9) SEE CHART C70 AIR CONDITIONING RUNS CONTINUOUSLY (11).                                |
| B9 NO CONNECTION                         |               |                                    |                     |              |               |   |
| B10 NO CONNECTION                        |               |                                    |                     |              |               |   |
| B11 NO CONNECTION                        |               |                                    |                     |              |               |   |
| B12 OCTANE ADJUST INPUT SIGNAL           | GREEN         | OCTANE ADJUST PIN "1"              |                     |              | 54            | SPARK KNOCK   |

- 1 Battery voltage for first two seconds, after ignition is turned "ON" without cranking the engine.
- 2 When vehicle is stopped, voltage will be either less than 1 volt or greater than 10 volts; depending upon position of drive wheels. When vehicle is moving, voltage will vary depending upon vehicle speed.
- 3 Varies with temperature.
- 4 Varies. With ignition "ON" reads barometric pressure. With engine running, reads engine load.
- 5 Voltage will vary with engine revolutions per minute.
- 6 Depending on octane adjust potentiometer trim.
- 7 Battery voltage (B +) with engine warm.
- 8 Open.
- 9 Open/Grounded circuit.
- 10 Grounded circuit.
- 11 Short to +12 volts.
  - \* Less than 0.50 volts.
  - \*\* Less than 0.10 volts.
  - \*\*\*\* Air Conditioning Vehicles Only
- B+ Should equal battery voltage.

24-PIN A-B CONNECTOR



BACK VIEW OF CONNECTOR

S-27-92  
NS 14375

## ELECTRONIC CONTROL MODULE PIN CONNECTOR "C" SYMPTOMS CHART 32-PIN C-D CONNECTOR

This electronic control module symptoms chart is for use with a digital voltmeter to further aid in diagnosis. The voltages you get may vary due to low battery charge or other reasons, but they should be very close.

**BACKPROBE CONNECTORS ONLY!**

**THE FOLLOWING CONDITIONS MUST BE MET BEFORE TESTING:**

- Engine at operating temperature
- Engine idling (For "Engine Run" column)
- Diagnostic "test" terminal not grounded
- Tech 1 "Scan" tool not installed
- Air conditioning "OFF"
- Digital voltmeter "-" (negative) lead connected to a good clean ground point.

| PIN FUNCTION   | WIRE COLOR      | COMPONENT/<br>CONNECTOR<br>CAVITY   | NORMAL VOLTAGE |             | CODES<br>AFFECT.  | POSSIBLE SYMPTOMS FROM<br>FAULTY CIRCUIT  |
|--|-----------------|---|----------------|-------------|-------------------|---|
|  |                 |   | IGN<br>"ON"    | ENG.<br>RUN |                   |   |
| C1 NO CONNECTION                                       |                 |   |                |             |                   |   |
| C2 INTAKE MANIFOLD<br>ELECTRIC HEATER<br>RELAY CONTROL | PINK/<br>BLACK  | INTAKE MANIFOLD<br>HEATER RELAY<br>CONNECTOR "4"                                | B+ (8)         | B+          | NONE              | COLD DRIVEABILITY COMPLAINTS.   |
| C3 IDLE AIR CONTROL<br>COIL "B" LOW                    | GREEN/<br>BLACK | IDLE AIR<br>CONTROL VALVE "A"   | NOT            | USEABLE     | 35                | STALLING, ROUGH, UNSTABLE OR<br>INCORRECT IDLE (9). SEE CHART C-2C.   |
| C4 IDLE AIR CONTROL<br>COIL "B" HIGH                   | GREEN/<br>WHITE | IDLE AIR<br>CONTROL VALVE "B"   | NOT            | USEABLE     | 35                | STALLING, ROUGH, UNSTABLE OR<br>INCORRECT IDLE (9). SEE CHART C-2C.   |
| C5 IDLE AIR CONTROL<br>COIL "A" LOW                    | BLUE/<br>BLACK  | IDLE AIR<br>CONTROL VALVE "C"   | NOT            | USEABLE     | 35                | STALLING, ROUGH, UNSTABLE OR<br>INCORRECT IDLE (9). SEE CHART C-2C.   |
| C6 IDLE AIR CONTROL<br>COIL "A" HIGH                   | BLUE/<br>WHITE  | IDLE AIR<br>CONTROL VALVE "D"   | NOT            | USEABLE     | 35                | STALLING, ROUGH, UNSTABLE OR<br>INCORRECT IDLE (9). SEE CHART C-2C.   |
| C7 NO CONNECTION                                       |                 |   |                |             |                   |   |
| C8 NO CONNECTION                                       |                 |   |                |             |                   |   |
| C9 NO CONNECTION                                       |                 |   |                |             |                   |   |
| C10 COOLANT<br>TEMPERATURE<br>INPUT SIGNAL             | YELLOW          | COOLANT<br>TEMPERATURE<br>SENSOR "B"  | (4) 1-2        | 1-2         | 14, 15            | HARD TO START, HIGH EXHAUST<br>EMISSIONS (9).   |
| C11 MANIFOLD ABSOLUTE<br>PRESSURE<br>INPUT SIGNAL      | GREEN           | MANIFOLD<br>ABSOLUTE PRESSURE<br>SENSOR "B"                                     | 3.5 - 5.0 (5)  | 0.9 - 1.5   | 33, 34            | POOR PERFORMANCE, ROUGH IDLE,<br>STALLING (9). SEE CHART C-1D.  |
| C12 INTAKE AIR<br>TEMPERATURE<br>INPUT SIGNAL          | WHITE           | INTAKE AIR<br>TEMPERATURE<br>SENSOR "B"   | 1,3            | 1,3         | 23, 25            | POSSIBLE STRONG EXHAUST.<br>TECH 1 READS -30°C (-36°F) (9).<br>TECH 1 READS 179°C (354°F) (9).                                |
| C13 THROTTLE POSITION<br>INPUT SIGNAL                  | BLUE            | THROTTLE POSITION<br>SENSOR "C"   | 0.3 - 0.7      | 0.3 - 0.7   | 21, 22            | POOR PERFORMANCE, HIGH IDLE (9)<br>SEE CHART C-1H. HARD TO START<br>WHEN COLD (11).   |
| C14 +5 VOLTS<br>REFERENCE OUTPUT                       | GRAY            | THROTTLE POSITION<br>SENSOR "A",<br>MANIFOLD ABSOLUTE<br>PRESSURE<br>SENSOR "C" | 5              | 5           | 21, 22,<br>33, 34 | SURGE, RUNS ROUGH, HIGH IDLE,<br>HARD TO START, EXCESSIVE EXHAUST<br>EMISSIONS OR ODORS, POOR<br>PERFORMANCE, ROUGH IDLE (9). |
| C15 NO CONNECTION                                      |                 |   |                |             |                   |   |
| C16 (POWER SUPPLY)<br>BATTERY +                        | RED             | ELECTRONIC<br>CONTROL<br>MODULE<br>"C-15"                                       | B+             | B+          | NONE              | FUSIBLE LINK BLOWN; NO START (10).<br>IF "C16" AND "B1" OPEN, NO START.<br>SEE "DIAGNOSTIC CIRCUIT CHECK."                    |

- |   |  |   |
|---|--|---|
| <p>1 Battery voltage for first two seconds, after ignition is turned "ON" without cranking the engine.</p> <p>2 When vehicle is stopped, voltage will be either less than 1 volt or greater than 10 volts; depending upon position of drive wheels. When vehicle is moving, voltage will vary depending upon vehicle speed.</p> <p>3 Varies with temperature.</p> | <p>4 Varies. With ignition "ON" reads barometric pressure. With engine running, reads engine load.</p> <p>5 Voltage will vary with engine revolutions per minute.</p> <p>6 Depending on octane adjust potentiometer trim.</p> <p>7 Battery voltage (B+) with engine warm.</p> <p>8 Open.</p> | <p>9 Open/grounded circuit.</p> <p>10 Grounded circuit.</p> <p>11 Short to +12 volts.</p> <p>• Less than 0.50 volts.</p> <p>•• Less than 0.10 volts.</p> <p>•••• Air Conditioning Vehicles Only</p> <p>B+ Should equal battery voltage.</p> |
|---|--|---|

S-27-92  
NS 14376

## 2-118 ENGINE MANAGEMENT SYSTEMS 1.7L THROTTLE BODY INJECTION

### ELECTRONIC CONTROL MODULE PIN CONNECTOR "D" SYMPTOMS CHART 32-PIN C-D CONNECTOR

This electronic control module symptoms chart is for use with a digital voltmeter to further aid in diagnosis. The voltages you get may vary due to low battery charge or other reasons, but they should be very close.

**BACKPROBE CONNECTORS ONLY!**

**THE FOLLOWING CONDITIONS MUST BE MET BEFORE TESTING:**

- Engine at operating temperature
- Engine idling (For "Engine Run" column)
- Diagnostic "test" terminal not grounded
- Tech 1 "Scan" tool not installed
- Air conditioning "OFF"
- Digital voltmeter "-" (negative) lead connected to a good clean ground point.

| PIN FUNCTION   | WIRE COLOR  | COMPONENT/<br>CONNECTOR<br>CAVITY   | NORMAL VOLTAGE |             | CODES<br>AFFECT. | POSSIBLE SYMPTOMS FROM<br>FAULTY CIRCUIT   |
|--|-------------|---|----------------|-------------|------------------|--|
|  |             |   | IGN<br>"ON"    | ENG.<br>RUN |                  |  |
| D1 ELECTRONIC CONTROL MODULE GROUND  | BROWN       | ENGINE GROUND   | 0**            | 0**         | NONE             | "A-12" AND "D-1" OPEN, NO START. SEE "DIAGNOSTIC CIRCUIT CHECK," SEE TERMINAL "A12"                                      |
| D2 OCTANE ADJUST POTENTIOMETER, MANIFOLD ABSOLUTE PRESSURE SENSOR AND INTAKE AIR TEMPERATURE SENSOR GROUND | BLACK       | OCTANE ADJUST "3" MANIFOLD ABSOLUTE PRESSURE "A" MANIFOLD AIR TEMPERATURE "A" | 0**            | 0**         | 54, 33, 23       | ROUGH OR UNSTABLE IDLE, MAY STALL, POOR PERFORMANCE (8) SEE CHART C-1D.  |
| D3 NO CONNECTION   |             |   |                |             |                  |  |
| D4 ELECTRONIC SPARK TIMING OUTPUT  | GREEN/WHITE | 6-PIN CONNECTOR "C"   | (5) 0*         | 1, 12       | 42               | HARD TO START, STALLS, WILL RESTART IN BYPASS MODE. SEE CHART C-4 (9). STALLS, POOR IDLE, MAY SET CODE 42 (11).          |
| D5 IGNITION MODULE BYPASS CONTROL  | BLACK/WHITE | 6-PIN CONNECTOR "D"   | 0              | 4, 6        | 42               | LACK OF POWER, POOR PERFORMANCE (9, 11) BY-PASS MODE, SEE CHART C-4.   |
| D6 OXYGEN SENSOR GROUND  | BROWN       | ENGINE GROUND   | 0**            | 0*          | 13               | OPEN LOOP, TECH 1 READS FIXED 400-500 mV (9).  |
| D7 OXYGEN SENSOR INPUT SIGNAL  | PINK        | OXYGEN SENSOR   | .45mV          | .1 - .9mV   | 13               | OPEN LOOP, STRONG EXHAUST ODOR (9).  |
| D8 NO CONNECTION   |             |   |                |             |                  |  |
| D9 INJECTOR CIRCUIT CURRENT LIMITED JUMPER   | BLACK       | ELECTRONIC CONTROL MODULE "D10"   | 0**            | 0**         | NONE             | NO START (8, 11). MAY DAMAGE ELECTRONIC CONTROL MODULE OR INJECTOR (10).   |
| D10 INJECTOR CIRCUIT CURRENT LIMITED JUMPER  | BLACK       | ELECTRONIC CONTROL MODULE "D9"  | 0**            | 0**         | NONE             | NO START (8, 11). MAY DAMAGE ELECTRONIC CONTROL MODULE OR INJECTOR (10).   |
| D11 NO CONNECTION  |             |   |                |             |                  |  |
| D12 AIR CONDITIONING COMPRESSOR CLUTCH RELAY CONTROL   | BLUE        | AIR CONDITIONING RELAY #2   | 0*             | 0*          | NONE             | NO AIR CONDITIONING (8, 11). AIR CONDITIONING RUNS ALL THE TIME (10).  |
| D13 NO CONNECTION  |             |   |                |             |                  |  |
| D14 NO CONNECTION  |             |   |                |             |                  |  |
| D15 NO CONNECTION  |             |   |                |             |                  |  |
| D16 FUEL INJECTOR CONTROL  | BLUE        | ELECTRONIC CONTROL MODULE "D16"   | B+             | B+          | NONE             | IF "D16" IS OPEN, NO START. SEE CHART A-3. FLOOD ENGINE, FAIL ELECTRONIC CONTROL MODULE OR INJECTOR (10). NO START (11). |

- 5 Voltage will vary with engine revolutions per minute.
- 6 Depending on octane adjust potentiometer trim.
- 7 Battery voltage (B +) with engine warm.
- 8 Open.

- 9 Open/Grounded circuit.
- 10 Grounded circuit.
- 11 Short to +12 volts.
- \* Less than 0,50 volts.
- \*\* Less than 0,10 volts.
- B+ Should equal battery voltage.

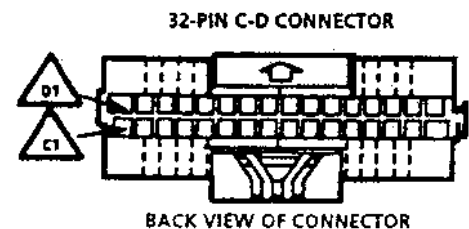

6-2-92  
NS 14377

## SECTION 2.9C

## COMPONENT SYSTEM CHARTS CONTENTS

|            |  | Page  |
|------------|--|-------|
| Chart C-1D | Manifold Absolute Pressure Output Check.....           | 2-120 |
| Chart C-1H | Throttle Position Sensor Output Check.....             | 2-122 |
| Chart C-2C | Idle Air Control Circuit Check.....                    | 2-124 |
| Chart C-3  | Canister Purge Valve Check.....                        | 2-126 |
| Chart C-4  | Ignition System Check (No Spark).....                  | 2-128 |
| Chart C-4B | Direct Ignition System Misfire <u>At Idle</u> .....    | 2-132 |
| Chart C-4C | Direct Ignition System Misfire <u>Under Load</u> ..... | 2-136 |
| Chart C-9  | Intake Manifold Electric Heater.....                   | 2-138 |
| Chart C-10 | Air Conditioning Compressor Clutch Control.....        | 2-142 |
| Chart C-13 | Crankcase Ventilation System Check.....                | 2-144 |
| Chart C-15 | Octane Adjustment Potentiometer Check.....             | 2-146 |

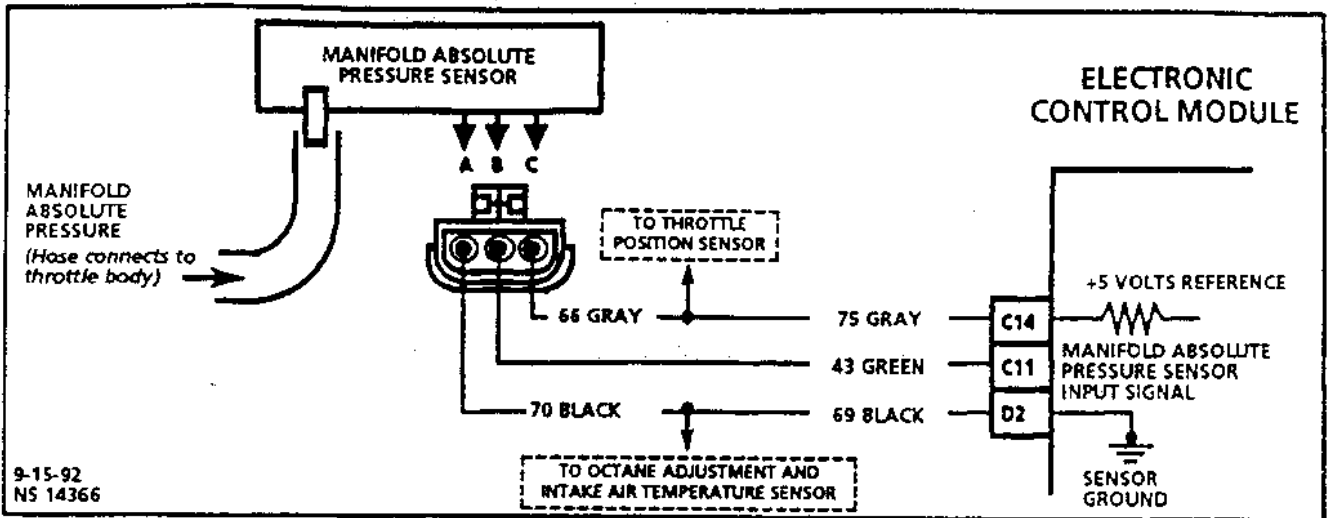

**CHART C-1D**  
**MANIFOLD ABSOLUTE PRESSURE OUTPUT CHECK**  
**1.7L THROTTLE BODY INJECTION NIVA**

**Circuit Description:**

The manifold absolute pressure sensor measures the changes in the intake manifold pressure which result from engine load (intake manifold vacuum) and revolutions per minute changes; and converts these into a voltage output. The electronic control module sends a 5 volt reference voltage to the manifold absolute pressure sensor. As the manifold pressure changes, the output voltage of the sensor also changes. By monitoring the sensor output voltage, the electronic control module knows the manifold pressure. A lower pressure (low voltage) output will be about 1-2 volts at idle. While higher pressure (high voltage) output will be about 4-4.8 at wide open throttle. The manifold absolute pressure sensor is also used, under certain conditions, to measure barometric pressure, allowing the electronic control module to make adjustments for different altitudes. The electronic control module uses the manifold absolute pressure sensor to control fuel delivery and ignition timing.

**Test Description:** Number(s) below refer to circled number(s) on the diagnostic chart.

**⚠ Important**

- Be sure to use the same diagnostic test equipment for all measurements.
1. Checks manifold absolute pressure sensor output voltage to the electronic control module. This voltage, without engine running, represents a barometer reading to the electronic control module. Comparison of this barometric reading on the same day with a known good vehicle is a good way to check accuracy of a "suspect" sensor. Readings should be the same  $\pm 0.2$  volt.
  2. Allowing 0.34 BAR (10" Hg) vacuum to the manifold absolute pressure sensor should cause the voltage to be at least 1.2 volts less than the voltage at Step 1. Upon applying vacuum to the sensor, the change in voltage should be instantaneous. A slow voltage change indicates a faulty sensor.

3. Check vacuum hose to sensor for leaking or restriction. Be sure no other vacuum devices are connected to the manifold absolute pressure sensor hose.

**NOTICE:** The engine must be running in this step or the Tech 1 will not indicate a change in voltage. It is normal for the "Check Engine" light to come "ON" and for the system to set a Code 33 during this step. Make sure the code is cleared when this test is completed.

4. Disconnect sensor from bracket and twist sensor (BY HAND ONLY) to check for intermittent connection. Output changes greater than 0.1 volt indicate a faulty connector or connection. If OK, replace sensor.

## CHART C-1D MANIFOLD ABSOLUTE PRESSURE OUTPUT CHECK 1.7L THROTTLE BODY INJECTION NIVA

NOTE: THIS CHART APPLIES ONLY TO MAP SENSORS HAVING GREEN OR BLACK COLOR KEY INSERT (SEE BELOW).

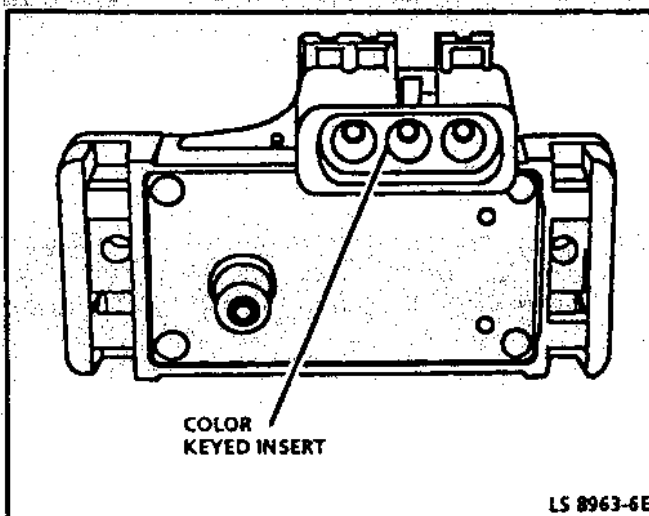
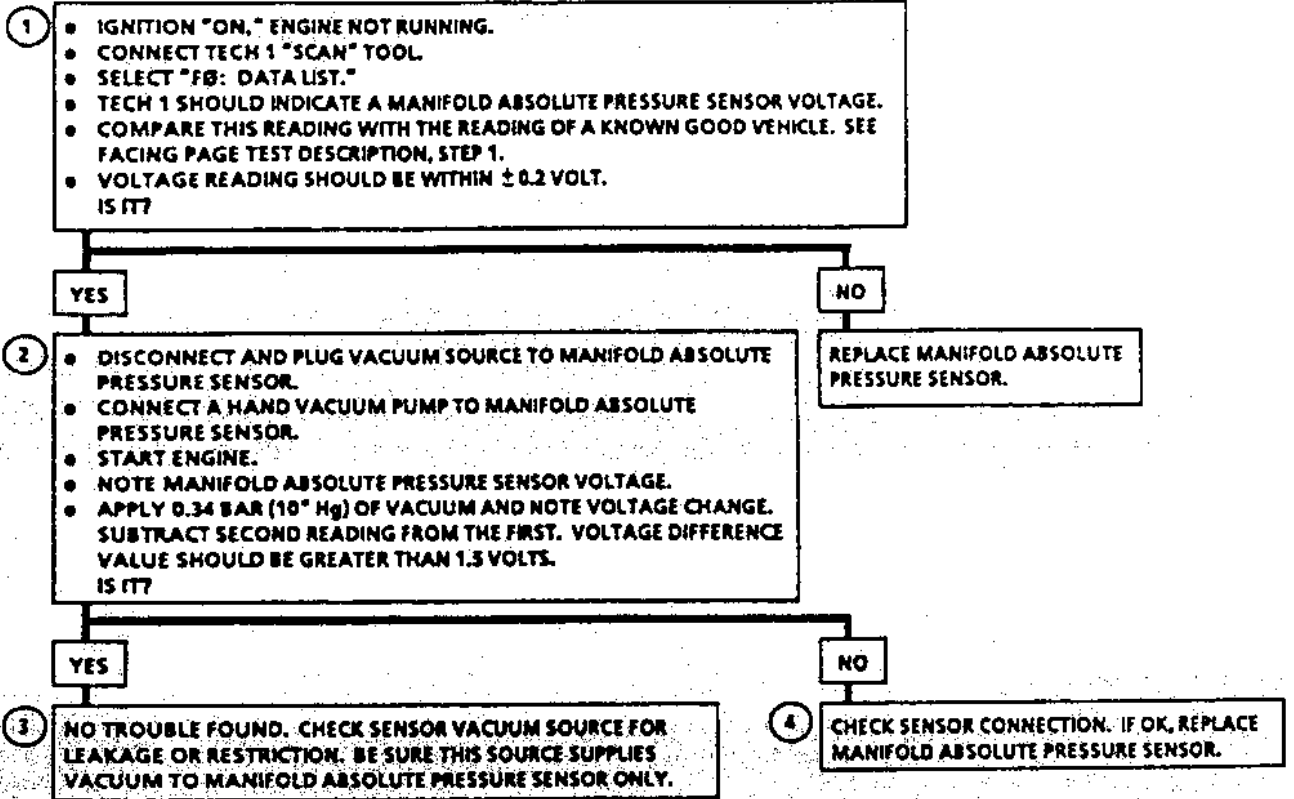

Figure 1 - Typical Key Insert

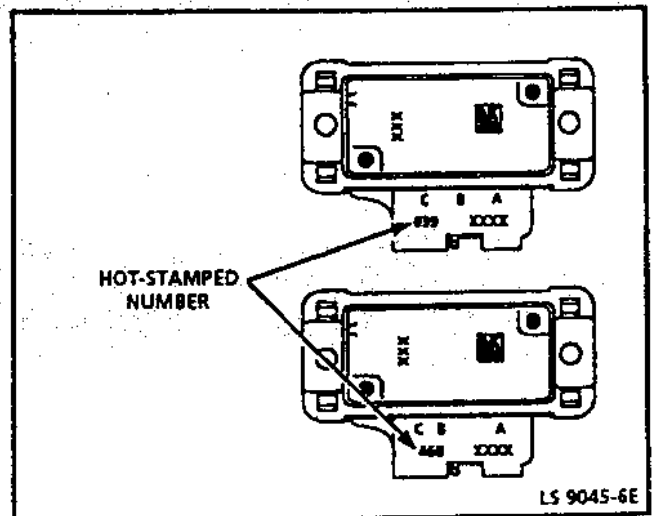
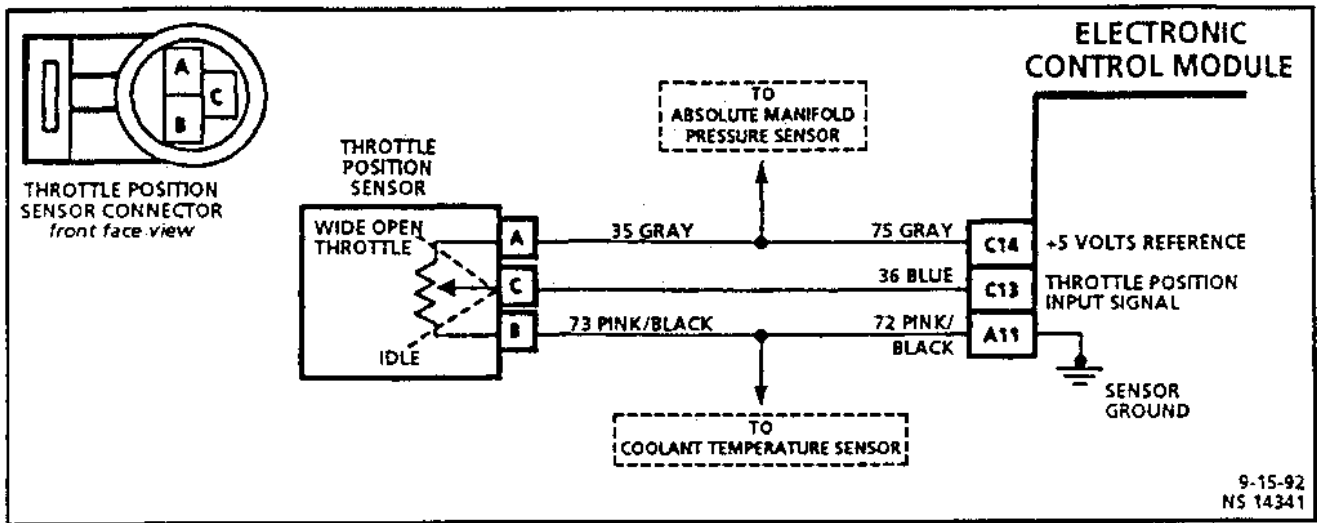

Figure 2 - Typical Hot-Stamped Number

"AFTER REPAIRS," START ENGINE, CLEAR CODES AND CONFIRM NO "CHECK ENGINE" LIGHT.

9-17-92  
NS 14379



**CHART C-1H**  
**THROTTLE POSITION SENSOR OUTPUT CHECK**  
**1.7L THROTTLE BODY INJECTION NIVA**

**Circuit Description:**

The throttle position sensor is attached to the throttle body, and is internally rotated by the throttle body shaft. It is a potentiometer with one end connected to 5 volts from the electronic control module and the other to electronic control module ground. A third wire is connected to the electronic control module, allowing it to measure the variable output voltage from the throttle position sensor.

As the throttle valve angle is changed (accelerator pedal moved), the throttle position sensor output voltage also changes in proportion. At a closed throttle position, the output voltage is usually below 1.0 volt. As the throttle valve opens, the output increases so that, at wide open throttle, the output should be above 4.0 volts. By monitoring the output voltage from the throttle position sensor, the electronic control module can determine fuel needs based on throttle opening (driver demand).

A broken or loose throttle position sensor, or one that has an unstable output, can cause intermittent bursts of fuel because the electronic control module thinks the throttle is moving. Results could include engine surge or poor idle quality. If the electronic control module interprets a high voltage when engine revolutions per minute is less than 420, hard starting could be the result ("clear-flood" mode). A problem in any of the throttle position sensor circuits will set either a Code 21 or 22 after the engine is started. Once a code is set, the electronic control module will use an artificial default value for throttle position sensor based on engine revolutions per minute to enable the vehicle to be driven, although performance could be less than normal.

The throttle position sensor is not adjustable. The electronic control module uses the reading at idle as "0% throttle," so no adjustment is necessary.

**Test Description:** Number(s) below refer to circled number(s) on the diagnostic chart.

1. This is a check of the voltage at the idle position. It is usually less than 1.0 volt.
2. The voltage should increase at the same steady rate at which the throttle is opened with the throttle valve.
3. With the throttle valve wide open, the throttle position sensor output needs to be above 4 volts, allowing the electronic control module to interpret a wide open throttle position.
4. If the closed-throttle voltage is over 2.5 volts, hard starting may be encountered (worse cold) due to "clear-flood" mode. This mode occurs when engine revolutions per minute is less than 420, and throttle position sensor input indicates the throttle is more than 80% open. Possible causes: short to voltage on throttle position sensor input signal circuit (Blue wire from throttle position sensor terminal "C" to electronic control module terminal "C13"), open ground circuit (Pink/Black wire from throttle position sensor terminal "B" to electronic control module terminal "A11"), or a faulty sensor.



## CHART C-1H

### THROTTLE POSITION SENSOR OUTPUT CHECK 1.7L THROTTLE BODY INJECTION NIVA

IF A CODE 21 OR 22 IS PRESENT,  
FOLLOW THAT CHART FIRST.

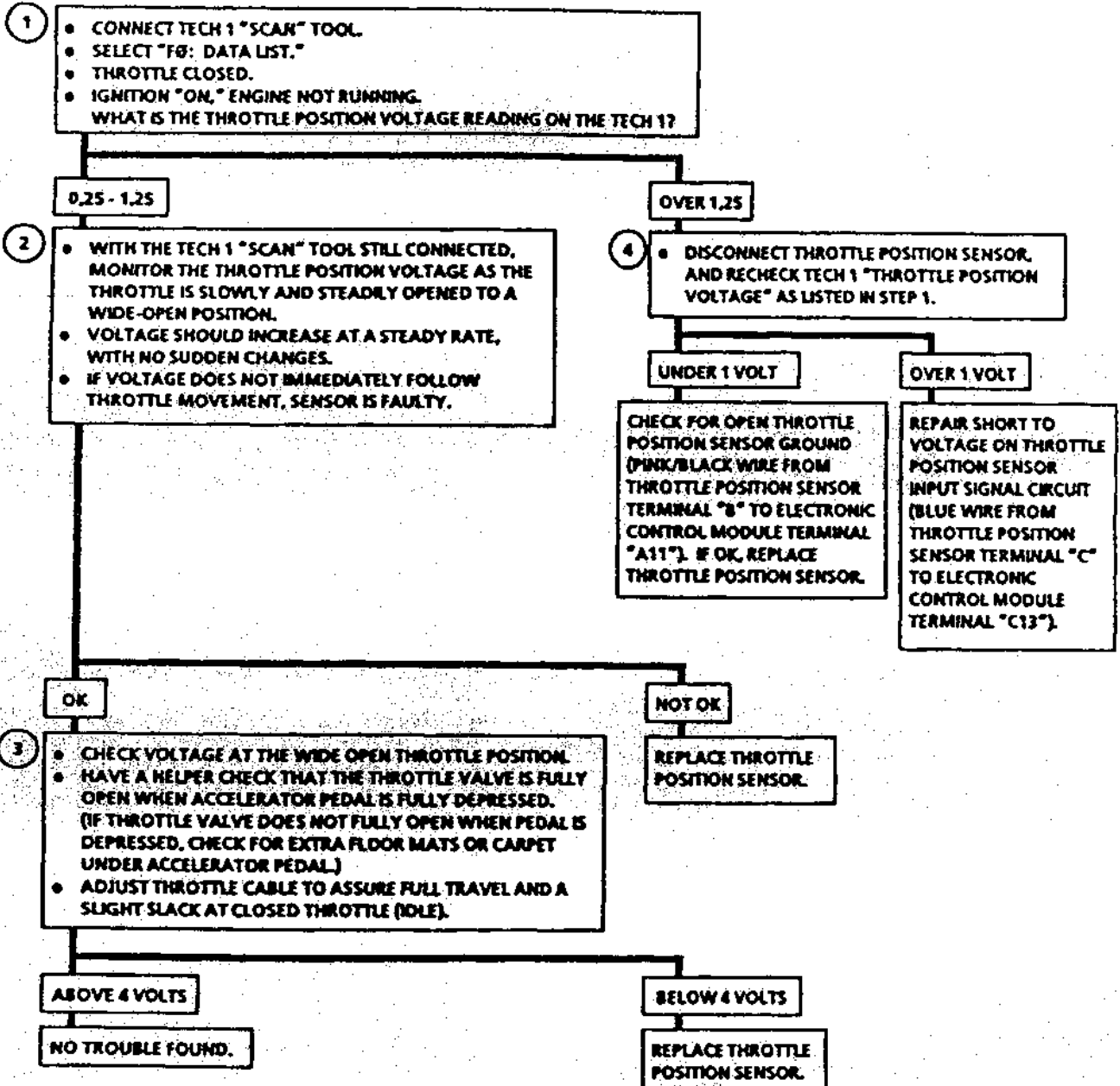

"AFTER REPAIRS," START ENGINE, CLEAR CODES AND CONFIRM NO "CHECK ENGINE" LIGHT.

9-17-92  
NS 14381

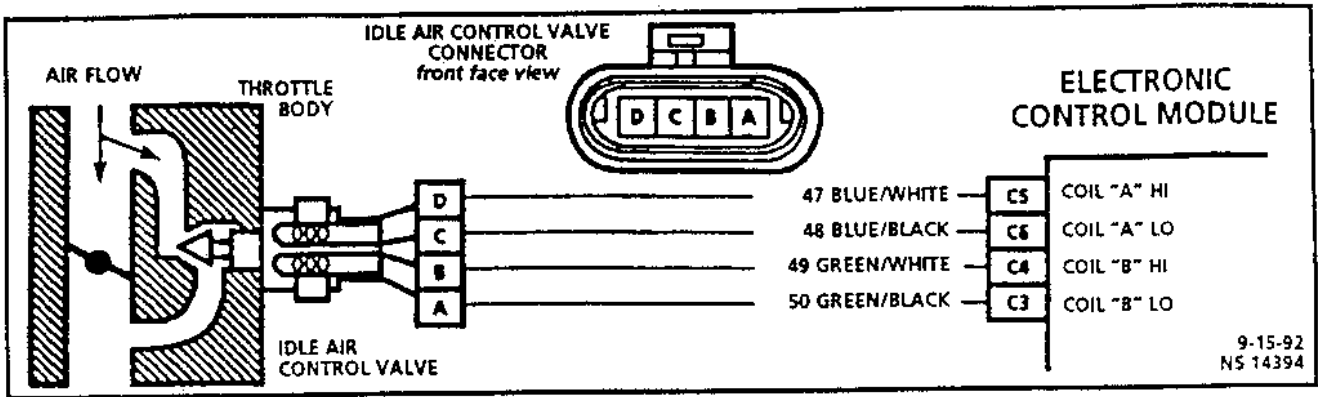

**CHART C-2C**  
**IDLE AIR CONTROL CIRCUIT CHECK**  
**1.7L THROTTLE BODY INJECTION NIVA**

**Circuit Description:**

The electronic control module controls idle revolutions per minute with the idle air control valve. To increase idle revolutions per minute, the electronic control module moves the idle air control valve out allowing more air to pass around the throttle plate. To decrease revolutions per minute, it moves the idle air control valve in, reducing air flow around the throttle plate. A Tech 1 "Scan" tool will read the electronic control module commands to the idle air control valve in counts.

**Test Description:** Number(s) below refer to circled number(s) on the diagnostic chart.

1. The Tech 1 revolutions per minute control mode is used to extend and retract the idle air control valve. The valve should move smoothly within the specified range. If the idle speed is commanded (idle air control extended) too low (below 750 revolutions per minute), the engine may stall. This may be normal and would not indicate a problem. Retracting the idle air control beyond its controlled range (above 1800 revolutions per minute) will cause a delay before the revolutions per minute start dropping. This too is normal.
2. This test uses the Tech 1 to command the idle air control controlled idle speed. The electronic control module issues commands to obtain commanded idle speed. The node lights each should flash red and green to indicate a good circuit as the electronic control module issues commands. While the sequence of color is not important if either light is "OFF" or does not flash red and green, check the circuits for faults, beginning with poor terminal contacts. Engine speed will not actually change, since the idle air control is disconnected.

**Diagnostic Aids:**

A slow, unstable, or fast idle may be caused by a non-idle air control system problem that cannot be overcome by the idle air control valve. Out of control range idle air control Tech 1 tool "idle air control" counts will be above 60 if idle is too low and zero counts if idle is too high. The following checks should be made to repair a non-idle air control system problem:

- **Vacuum Leak (High Idle).** If idle is too high, stop the engine. Fully extend (seat) idle air control using 222 DM idle air control "Motor Tester" in the A "Low Switch Position." Start engine. If idle speed is above 1000 revolutions per minute, locate and correct vacuum leak including Crankcase Ventilation System. Also check for binding of throttle blade or linkage.
- **Fuel System too lean (High Air/Fuel Ratio).** The idle speed may be too high or too low. Engine speed may vary up and down, and disconnecting the idle air control valve does not help. Check for low regulated fuel pressure, water in the fuel or a restricted injector.
- **Fuel System too rich (Low Air/Fuel Ratio).** The idle speed will be too low. "Scan" tool idle air control counts will usually be above 80. System would be obviously rich and may exhibit black smoke in exhaust. Check for high fuel pressure, leaking or sticking injector.
- **Throttle Body.** Remove idle air control valve and inspect bore and idle air passages for foreign material.
- **Idle Air Control Valve Electrical Connections.** Idle air control valve connections should be carefully checked for proper contact.
- **Crankcase Ventilation System.** A faulty system may result in an incorrect idle speed.
- Refer to "Rough, Unstable, Incorrect Idle or Stalling," in "Symptoms," Section "2.9B".
- If intermittent poor driveability or idle symptoms are resolved by disconnecting the idle air control, carefully recheck idle air control connections and terminal resistance.

## CHART C-2C IDLE AIR CONTROL CIRCUIT CHECK 1.7L THROTTLE BODY INJECTION NIVA

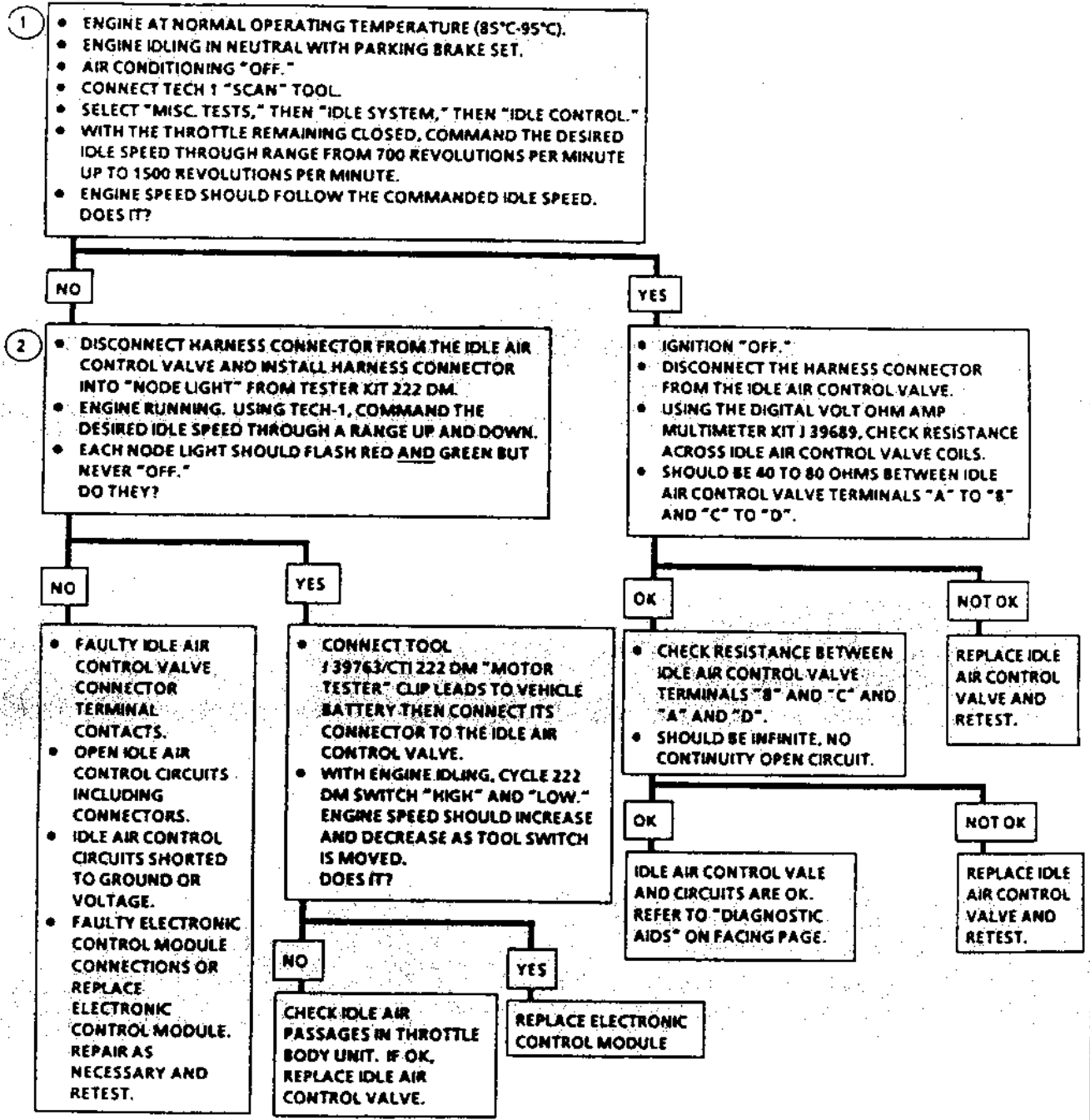

AFTER ALL IDLE AIR CONTROL TESTING IS COMPLETE, RESET THE IDLE AIR CONTROL VALVE. CONNECT TECH 1 "SCAN" TOOL. SELECT "MISC TEST," THEN "IDLE SYSTEM," THEN "IDLE RESET."

"AFTER REPAIRS," START ENGINE, CLEAR CODES AND CONFIRM NO "CHECK ENGINE" LIGHT.

3-9-93  
NS 14395

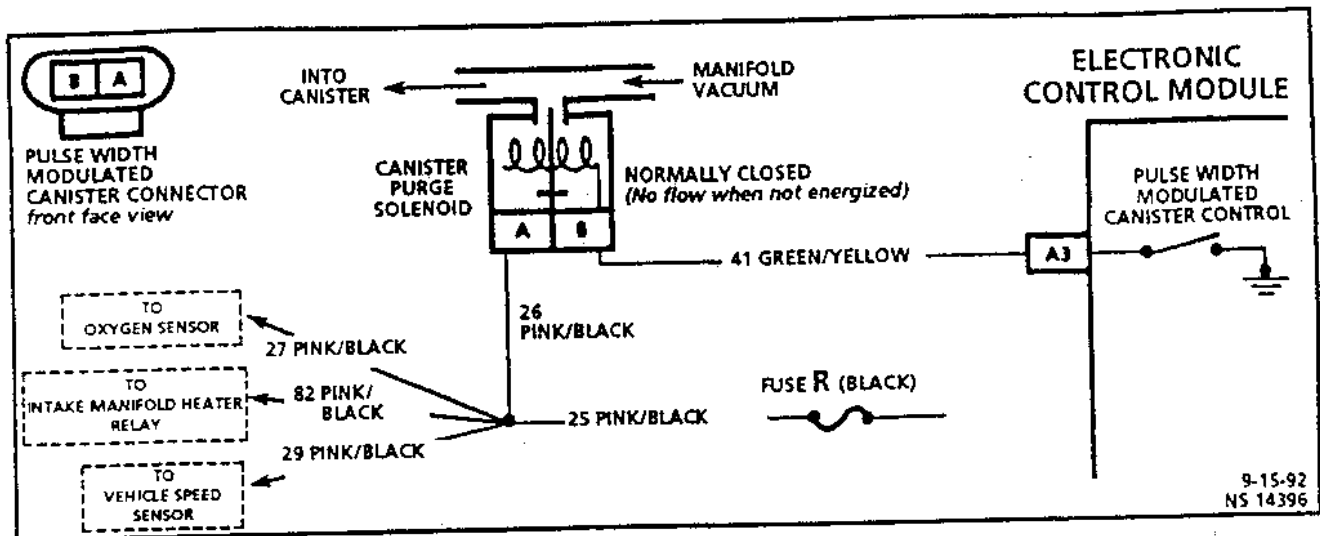

**CHART C-3**  
**CANISTER PURGE VALVE CHECK**  
**1.7L THROTTLE BODY INJECTION NIVA**

**Circuit Description:**

Canister purge is controlled by a solenoid that allows manifold vacuum to purge the canister when energized. The electronic control module supplies a ground to energize the solenoid (purge "ON"). The purge solenoid controlled by the electronic control module is pulse width modulated (turned "ON" and "OFF" several times a second). The duty cycle (pulse width) is calculated based on the current value of the "Closed Loop" fuel adjustment.

The duty cycle is calculated by the electronic control module and the output commanded when the following conditions have been met:

- Battery voltage is less than 16.9 volts.
- Coolant temperature above 80°C.
- Vehicle speed above 21 kilometers per hour.
- Throttle position has exceeded 2%.

Also, if the diagnostic "test" terminal is grounded, with the engine stopped, the purge solenoid is energized (purge "ON").

**NOTICE:** Once enabled it will remain enabled except during a wide open throttle condition.

**Test Description:** Number(s) below refer to circled number(s) on the diagnostic chart.

1. Checks to see if the solenoid is opened or closed. The solenoid is normally de-energized in this step; so it should be closed.
2. Checks for a complete circuit. Normally, there is ignition voltage on Circuit 25 and the electronic control module provides a ground on Circuit 41.
3. Completes functional check by grounding "test" terminal. This should normally de-energize the solenoid opening the valve which should allow the vacuum to drop (purge "ON").

**Diagnostic Aids:**

- If 10" Hg (34 kPa) of vacuum is not available at the solenoid check for:
  - Split or cracked hoses.
  - Pinched or plugged hoses.
  - Ensure hoses are installed correctly.
- When using the Tech 1 "Scan" tool to energize the solenoid, remember that this is an "OFF" and "ON" control only. The Tech 1 "Scan" tool is not capable of adjusting the pulse width.

### CHART C-3 CANISTER PURGE VALVE CHECK 1.7L THROTTLE BODY INJECTION NIVA

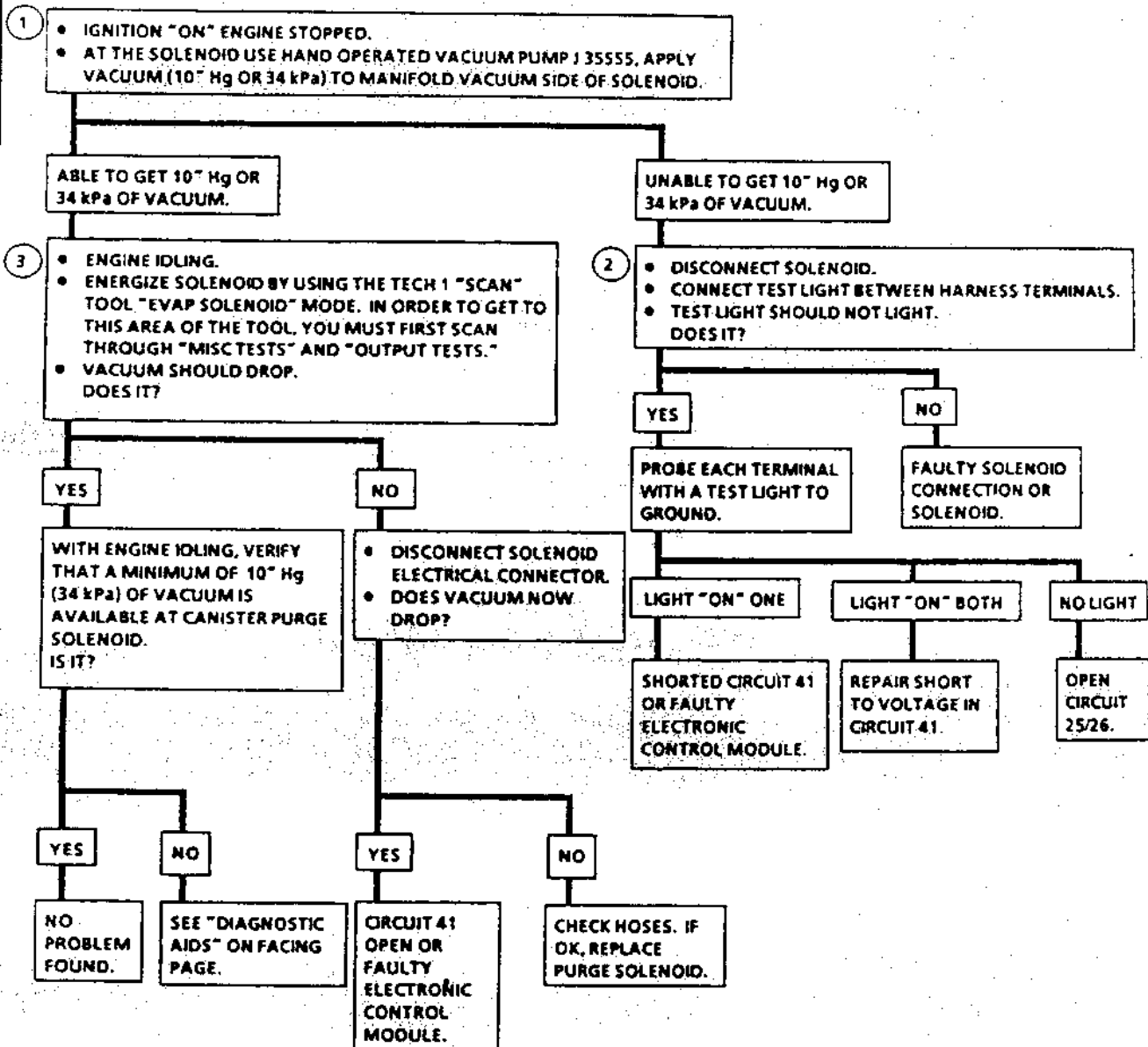

11-2-92  
NS 14397

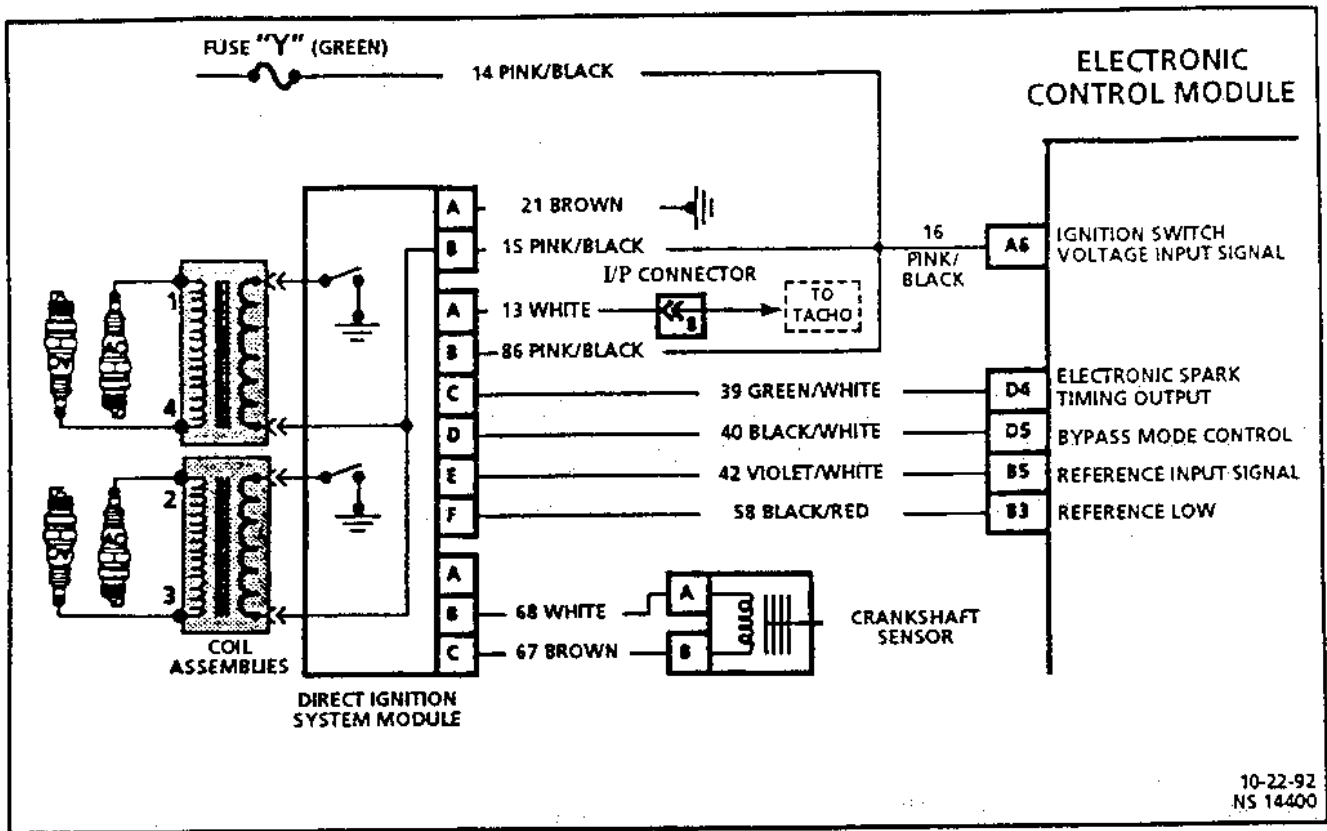

**CHART C-4**  
(Page 1 of 2)  
**IGNITION SYSTEM CHECK**  
(NO SPARK)  
**1.7L THROTTLE BODY INJECTION NIVA**

**Circuit Description:**

The direct ignition system uses a waste spark method of distribution. In this type of system, the ignition module triggers the correct ignition coil, based on signals from the crankshaft sensor. Each ignition coil provides the high secondary voltage required to fire two spark plugs at the same time on "companion" cylinders, i.e., cylinders with pistons at the top of their stroke top dead center at the same time. One of these pistons would be at the top of its compression stroke, the other piston would be at the top of its exhaust stroke.

**Test Description:** Number(s) below refer to circled number(s) on the diagnostic chart.

1. Because the direct ignition system uses two plugs and wires to complete the circuit of each coil, the opposite spark plug cable should be connected to ground.
2. This test will determine if + battery voltage is available at the ignition module.
3. This test will determine if a good ground is available at the ignition module.
4. Checks for continuity of the crankshaft position sensor and connections.
5. Voltage will vary in this test depending on cranking speed of engine.

**CHART C-4**  
 (Page 1 of 2)  
**IGNITION SYSTEM CHECK**  
 (NO SPARK)  
**1.7L THROTTLE BODY INJECTION NIVA**

NOTE: THIS CHART ASSUMES THAT THE TECHNICIAN HAS PERFORMED DIAGNOSTIC CIRCUIT CHECK CHART A.

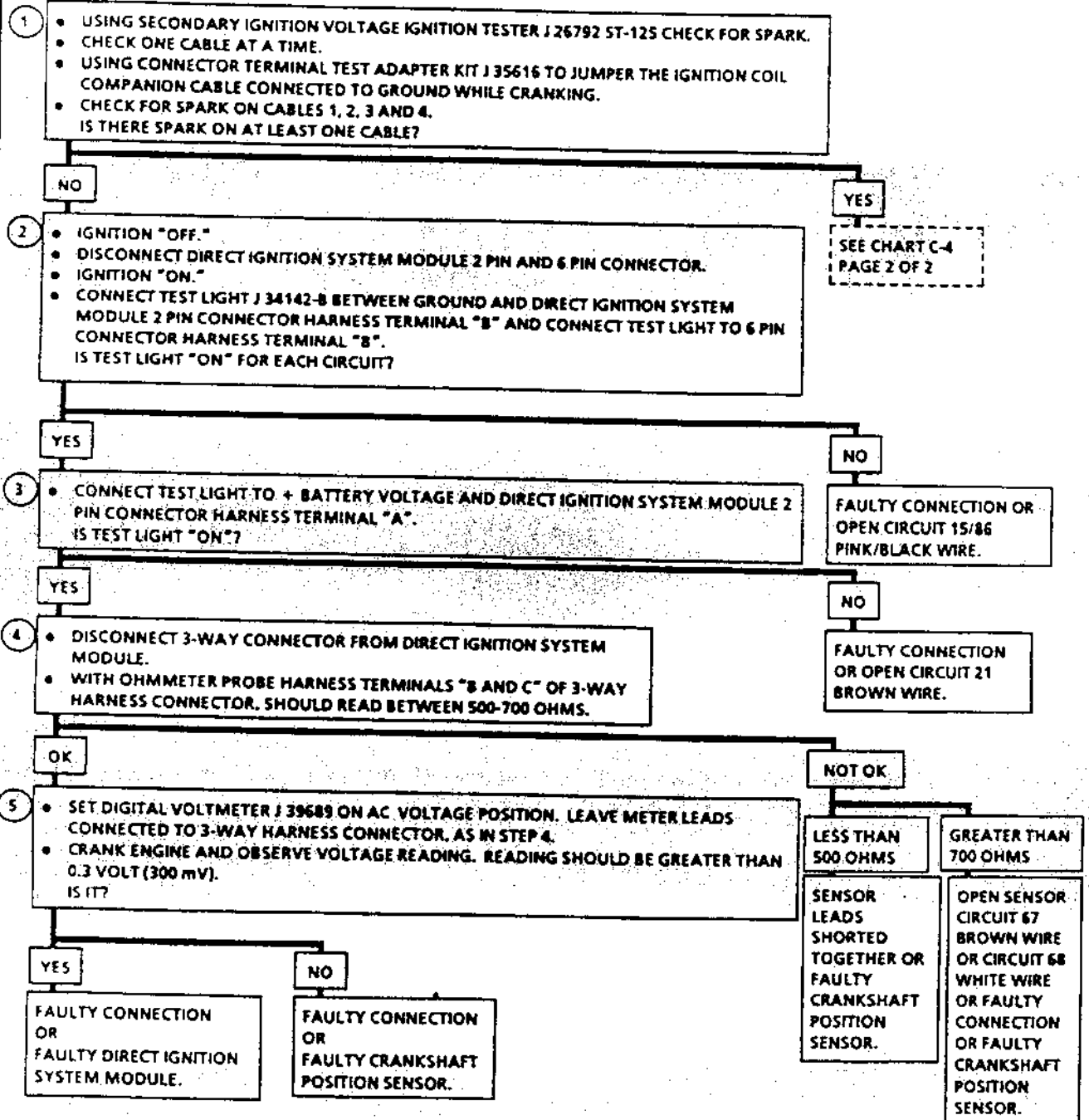

"AFTER REPAIRS," START ENGINE, CLEAR CODES AND CONFIRM NO "CHECK ENGINE" LIGHT.

2-8-93  
NS 14979

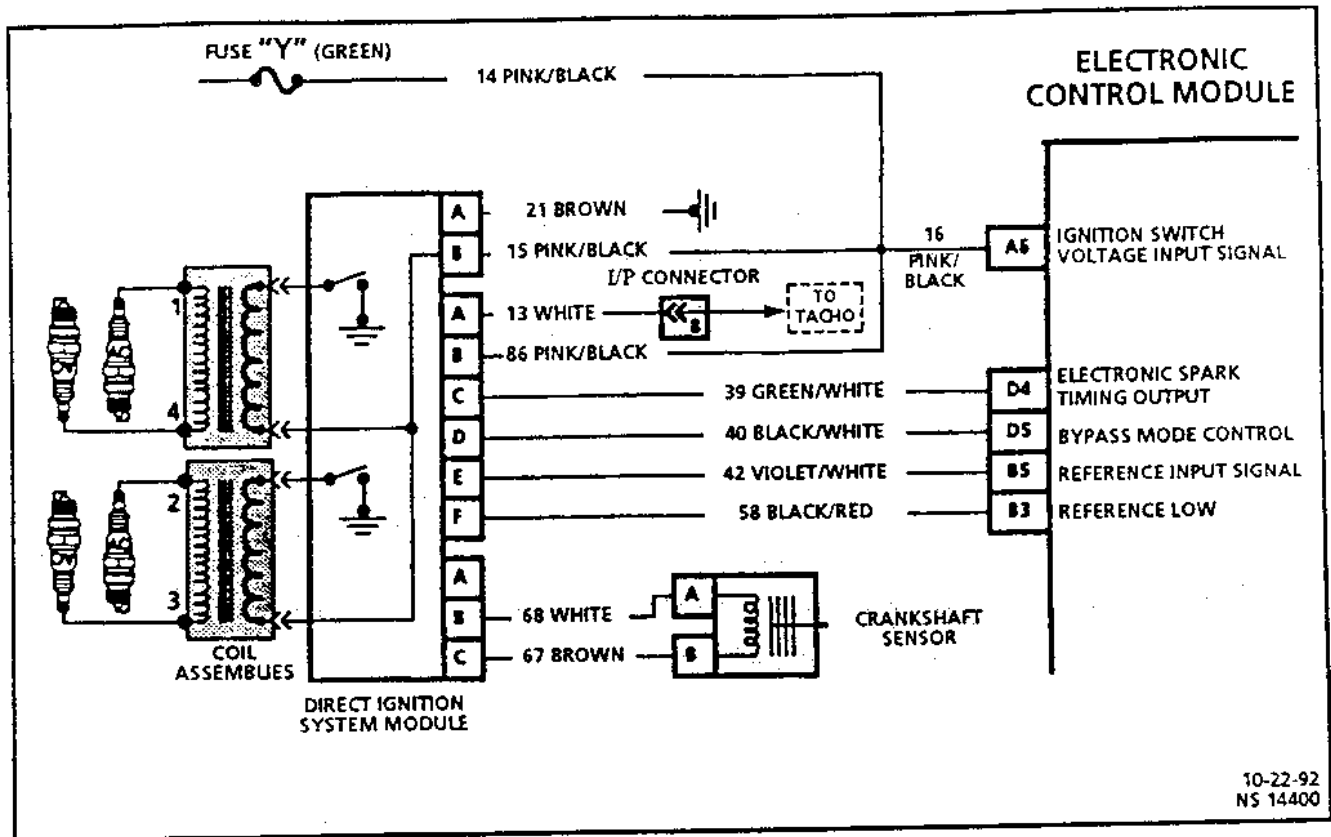

**CHART C-4**  
(Page 2 of 2)  
**IGNITION SYSTEM CHECK**  
(NO SPARK)  
**1.7L THROTTLE BODY INJECTION NIVA**

**Circuit Description:**

The direct ignition system uses a waste spark method of distribution. In this type of system, the ignition module triggers the correct ignition coil, based on signals from the crankshaft sensor. Each ignition coil provides the high secondary voltage required to fire two spark plugs at the same time on "companion" cylinders, i.e., cylinders with pistons at the top of their stroke top dead center at the same time. One of these pistons would be at the top of its compression stroke, the other piston would be at the top of its exhaust stroke.

**Test Description:** Number(s) below refer to circled number(s) on the diagnostic chart.

6. If carbon tracking is evident, replace coil and be sure plug wires relating to that coil are clean and tight. Excessive wire resistance or faulty connections could have caused the coil to be damaged.
7. This test will determine if the ignition module is not triggering the problem coil or if the tested coil is at fault. This test could also be performed by using another known good coil.



**CHART C-4**  
 (Page 2 of 2)  
**IGNITION SYSTEM CHECK**  
 (NO SPARK)  
**1.7L THROTTLE BODY INJECTION NIVA**

FROM CHART C-4  
 PAGE 1 OF 2

• USING DIGITAL VOLT OHM AMP MULTIMETER KIT J 39689 TO CHECK THE RESISTANCE OF EACH PLUG CABLE OF THE COIL WHICH DID NOT FIRE THE SPARK TESTER.  
 • CABLE RESISTANCE SHOULD BE LESS THAN 15,000 OHMS EACH AND WIRES SHOULD NOT BE GROUNDED.  
 ARE CABLES OK?

YES

NO

REPLACE FAULTY CABLE(S).

• MEASURE SECONDARY RESISTANCE OF IGNITION COIL BY CONNECTING EACH MULTIMETER LEAD ON EACH COIL TOWER TERMINAL.  
 IS RESISTANCE BETWEEN 5000 AND 7000 OHMS?

YES

NO

FAULTY IGNITION COIL.

6  
 • REMOVE COIL RETAINING NUTS AND REMOVE COIL.  
 • COIL SHOULD BE FREE OF CARBON TRACKING.  
 ARE THEY?

YES

NO

REPLACE IGNITION COIL. ALSO CHECK FOR FAULTY SPARK PLUG CABLE CONNECTION(S) AND WIRE NIPPLE(S) FOR CARBON TRACKING.

• MEASURE PRIMARY RESISTANCE OF IGNITION COIL BY CONNECTING EACH MULTIMETER LEAD ON EACH FEMALE TERMINAL ON BOTTOM OF IGNITION COIL.  
 IS RESISTANCE BETWEEN 0.3Ω AND 1.5Ω?

YES

NO

FAULTY CONNECTION OR FAULTY IGNITION COIL.

7  
 • USE TEST LIGHT J 34142-B AND CONNECTOR TERMINAL TEST ADAPTER KIT J 35616 TO JUMPER TEST LIGHT ACROSS IGNITION MODULE TERMINALS WHICH CONNECT TO IGNITION COIL PRIMARY TERMINALS.  
 • CRANK THE ENGINE WHILE OBSERVING TEST LIGHT.  
 DOES TEST LIGHT BLINK?

YES

NO

FAULTY IGNITION COIL TERMINAL CONNECTIONS OR FAULTY IGNITION COIL.

FAULTY IGNITION MODULE.

"AFTER REPAIRS," START ENGINE. CLEAR CODES AND CONFIRM NO "CHECK ENGINE" LIGHT.

3-27-93  
 NS 15201

## 2-132 ENGINE MANAGEMENT SYSTEMS 1.7L THROTTLE BODY INJECTION

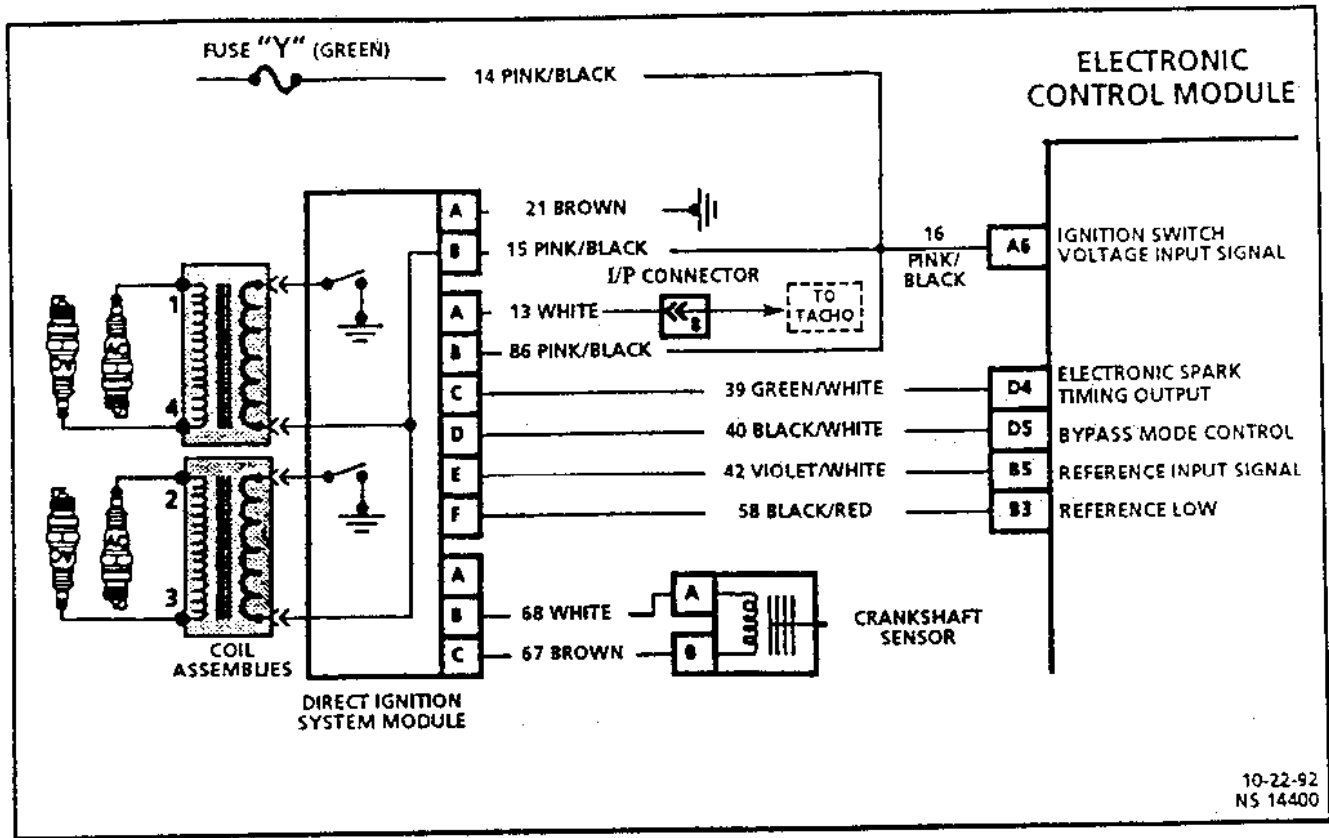

### CHART C-4B

(Page 1 of 2)

### DIRECT IGNITION SYSTEM MISFIRE AT IDLE 1.7L THROTTLE BODY INJECTION NIVA

#### Circuit Description:

The direct ignition system uses a waste spark method of distribution. In this type of system, the ignition module triggers the #1/4 coil pair resulting in both #1 and #4 spark plugs firing at the same time. #1 cylinder is on the compression stroke at the same time #4 is on the exhaust stroke, resulting in a lower energy requirement to fire #4 spark plug. This leaves the remainder of the high voltage to be used to fire #1 spark plug. On this application, the crankshaft position sensor is mounted to the engine block and protrudes to within approximately 1 mm of the crankshaft reluctor. Since the reluctor is a machined portion of the crankshaft pulley and the crank sensor is mounted in a fixed position on the block, timing adjustments are not possible or necessary.

**Test Description:** Number(s) below refer to circled number(s) on the diagnostic chart.

1. If the "Misfire" complaint exists *under load only*, diagnostic CHART C-4C must be used. Engine rpm should drop approximately equally on all plug leads.
2. A secondary ignition voltage ignition tester J 26792 (ST-125) must be used because it is essential to verify adequate available secondary voltage at the spark plug (25,000 volts).
3. If the spark jumps the test gap after grounding the opposite plug wire, it indicates excessive resistance in the plug which was bypassed. A faulty or poor connection at that plug could also result in the miss condition. Also check for carbon deposits inside the spark plug boot.

**CHART C-4B**  
 (Page 1 of 2)  
**DIRECT IGNITION SYSTEM**  
**MISFIRE AT IDLE**  
**1.7L THROTTLE BODY**  
**INJECTION NIVA**

1

- IF ENGINE MISFIRES UNDER LOAD ONLY, SEE CHART C-4C.
- IGNITION "OFF."
- DISCONNECT EACH SPARK PLUG CABLE FROM SPARK PLUG.
- INSTALL HIGH CARBON CONTENT VACUUM HOSE APPROXIMATELY 5 CM LONG ON SPARK PLUG AND CONNECT SPARK PLUG LEAD TO OTHER END OF VACUUM HOSE (VACUUM HOSE PIECES FOUND IN TERMINAL TEST ADAPTER KIT J 35616.)
- CONNECT TECH 1. SELECT "F0: DATA LIST."
- ENGINE IDLING AT NORMAL OPERATING TEMPERATURE, DISCONNECT IDLE AIR CONTROL VALVE.
- WITH TEST LIGHT J 34142-B CONNECTED TO GROUND MOMENTARILY TOUCH EACH VACUUM HOSE, WHILE OBSERVING "ENGINE SPEED" ON TECH 1. SEE CAUTION★.
- WHEN THE TEST LIGHT CONTACTS EACH VACUUM HOSE IT SHOULD RESULT IN AN ENGINE SPEED DROP. DID THEY?

NO

YES

2

- WITH IGNITION "OFF," INSTALL SECONDARY IGNITION VOLTAGE IGNITION TESTER J 26792 (ST-125) ON PLUG CABLE(S) WHOSE SHORT TO GROUND THROUGH TEST LIGHT DID NOT RESULT IN ENGINE SPEED DROP.
- SPARK SHOULD JUMP SECONDARY IGNITION VOLTAGE IGNITION TESTER GAP WHILE CRANKING ENGINE. DOES IT?

SEE "ROUGH, UNSTABLE OR INCORRECT IDLE OR STALLING" IN "SYMPTOMS" SECTION "B".

NO

YES

3

- WITH IGNITION "OFF," USING CONNECTOR TERMINAL TEST ADAPTER KIT J 35616 GROUND THE OPPOSITE PLUG CABLE OF THE AFFECTED COIL AT SPARK PLUG.
- SPARK SHOULD JUMP SECONDARY IGNITION VOLTAGE IGNITION TESTER GAP WHILE CRANKING ENGINE. DOES IT?

CHECK FOR:

- FAULTY, WORN OR CRACKED SPARK PLUG(S).
- PLUG FOULING DUE TO ENGINE MECHANICAL FAULT.

IF SPARK PLUGS CHECK OUT OK, SEE "CUTS OUT, MISSES" IN "SYMPTOMS" SECTION "2".

NO

YES

CONTINUE TO PAGE 2 OF 2

REPLACE THE SPARK PLUG FOR THE CABLE WHICH WAS JUMPERED TO GROUND. IF MISFIRE IS STILL PRESENT, START MISFIRE TEST AGAIN AT STEP #1.

★ CAUTION: When handling secondary spark plug cables with engine running, insulated pliers must be used and care exercised to prevent a possible electrical shock.

"AFTER REPAIRS," START ENGINE, CLEAR CODES AND CONFIRM NO "CHECK ENGINE" LIGHT.

4-27-93  
 NS 15804

## 2-134 ENGINE MANAGEMENT SYSTEMS 1.7L THROTTLE BODY INJECTION

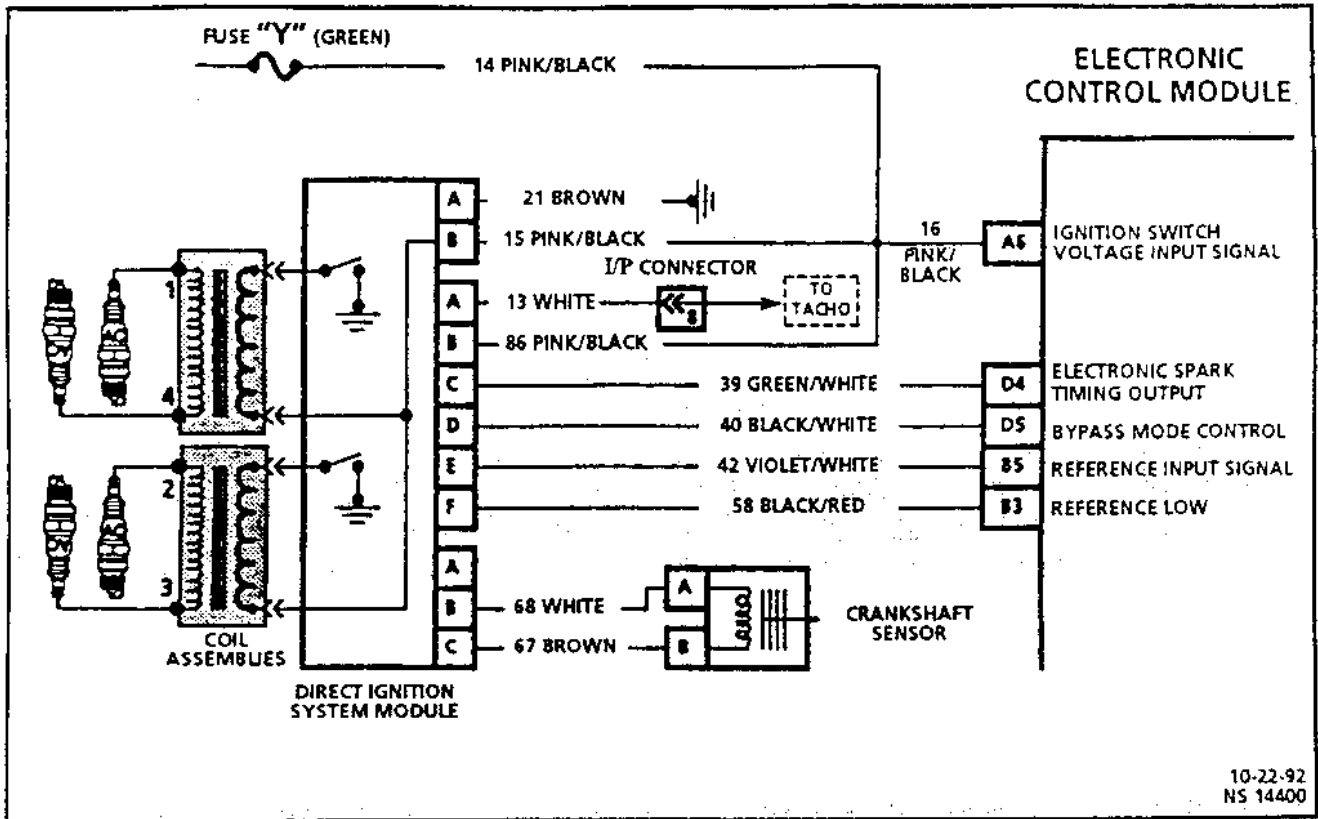

### CHART C-4B

(Page 2 of 2)

### DIRECT IGNITION SYSTEM MISFIRE AT IDLE 1.7L THROTTLE BODY INJECTION NIVA

#### Circuit Description:

The direct ignition system uses a waste spark method of distribution. In this type of system, the ignition module triggers the #1/4 coil pair resulting in both #1 and #4 spark plugs firing at the same time. #1 cylinder is on the compression stroke at the same time #4 is on the exhaust stroke, resulting in a lower energy requirement to fire #4 spark plug. This leaves the remainder of the high voltage to be used to fire #1 spark plug. On this application, the crankshaft position sensor is mounted to the engine block and protrudes to within approximately .050" of the crankshaft reluctor. Since the reluctor is a machined portion of the crankshaft pulley and the crank sensor is mounted in a fixed position on the block, timing adjustments are not possible or necessary.

**Test Description:** Number(s) below refer to circled number(s) on the diagnostic chart.

- To check the spark plug cable, use the digital multimeter J 39689 on the ohms scale. Disconnect the suspect spark plug cable from both ends and connect one of the multimeter probes to each end of the plug cable.
- If carbon tracking is evident, replace coil and be sure plug cables relating to that coil are clean and tight. Excessive cable resistance or faulty connections could have caused the coil to be damaged.
- If the "no spark" condition follows the suspected coil, that coil is faulty. Otherwise, the ignition module is the cause of no spark. This test could also be performed by substituting a known good coil for the one causing the "no spark" condition.

**CHART C-4B**  
 (Page 2 of 2)  
**DIRECT IGNITION SYSTEM**  
**MISFIRE AT IDLE**  
**1.7L THROTTLE BODY**  
**INJECTION NIVA**

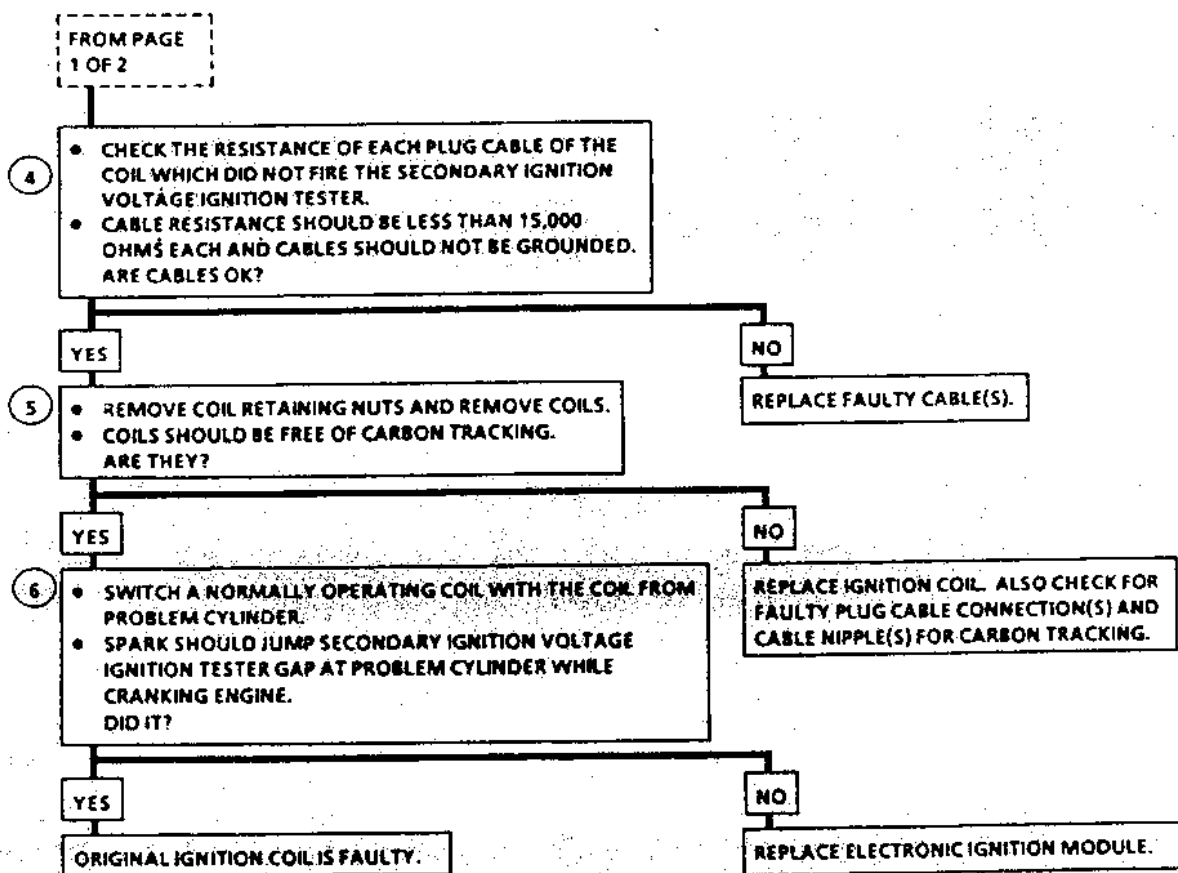

★ **CAUTION:** When handling secondary spark plug cables with engine running, insulated pliers must be used and care exercised to prevent a possible electrical shock.

"AFTER REPAIRS," START ENGINE, CLEAR CODES AND CONFIRM NO "CHECK ENGINE" LIGHT.

4-27-93  
 NS 14450

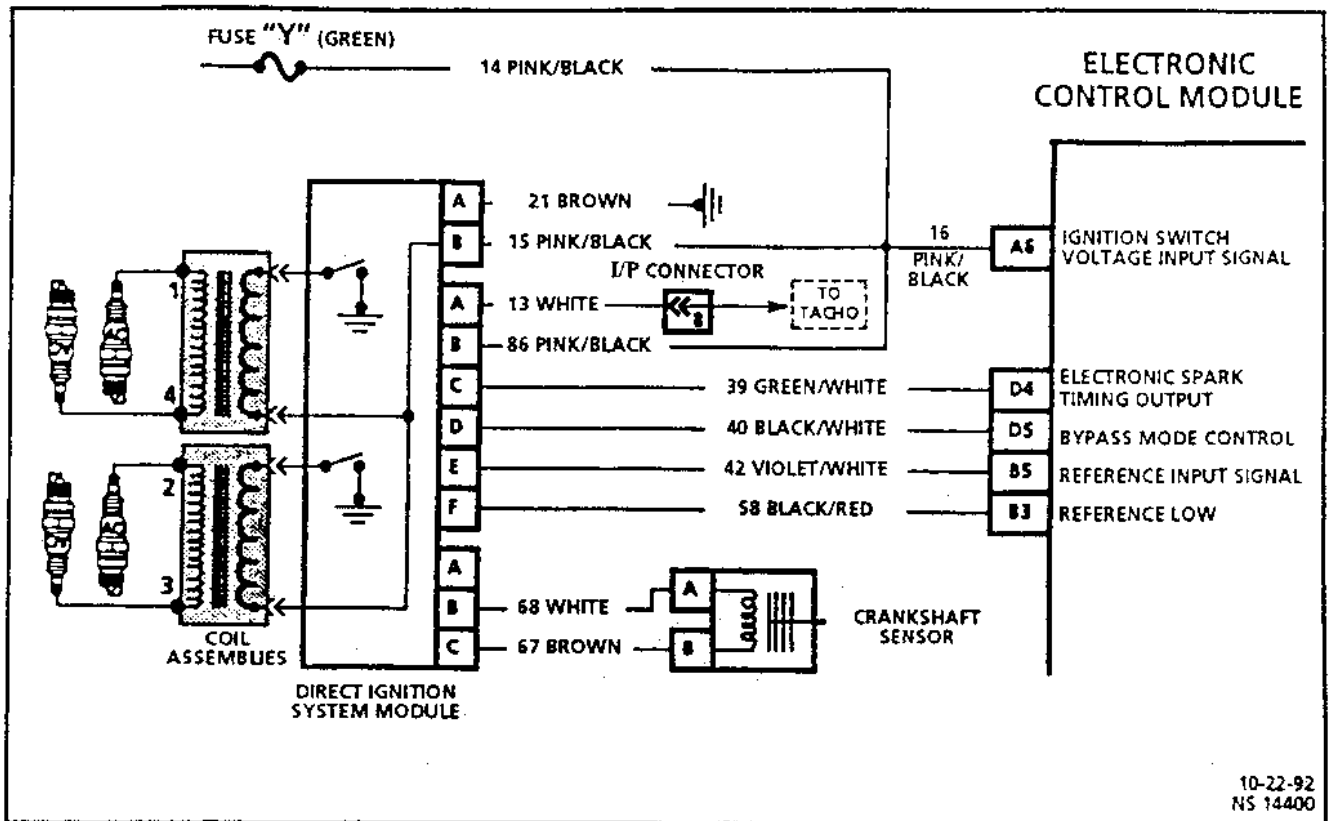

**CHART C-4C**  
**DIRECT IGNITION SYSTEM MISFIRE UNDER LOAD**  
**1.7L THROTTLE BODY INJECTION NIVA**

**Circuit Description:**

The direct ignition system uses a waste spark method of distribution. In this type of system, the ignition module triggers the #1/4 coil pair resulting in both #1 and #4 spark plugs firing at the same time. #1 cylinder is on the compression stroke at the same time #4 is on the exhaust stroke, resulting in a lower energy requirement to fire #4 spark plug. This leaves the remainder of the high voltage to be used to fire #1 spark plug. On this application the crankshaft position sensor is mounted to the engine block and protrudes to within approximately .050" of the crankshaft reluctor. Since the reluctor is a machined portion of the crankshaft and the crankshaft sensor is mounted in a fixed position on the block, timing adjustments are not possible or necessary.

**Test Description:** Number(s) below refer to circled number(s) on the diagnostic chart.

1. If the "Misfire" complaint exists *at idle only*, diagnostic CHART C-4B must be used. A secondary ignition voltage ignition tester J 26792 (ST-125) must be used because it is essential to verify adequate available secondary voltage at the spark plug (25,000 volts). Spark should jump the test gap on all 4 leads. This simulates a "load" condition.
2. If the spark jumps secondary ignition voltage ignition tester J 26792 (ST-125) gap after grounding the opposite plug wire, it indicates excessive resistance in the plug which was bypassed.
3. If carbon tracing is evident, replace coil and be sure plug wires relating to that coil are clean and tight. Excessive wire resistance or faulty connections could have caused the coil to be damaged.
4. If the no spark condition follows the suspected coil, that coil is faulty. Otherwise, the ignition module is the cause of no spark. This test could also be performed by substituting a known good coil for the one causing the no spark condition.

**CHART C-4C**  
**DIRECT IGNITION SYSTEM**  
**MISFIRE UNDER LOAD**  
**1.7L THROTTLE BODY**  
**INJECTION NIVA**

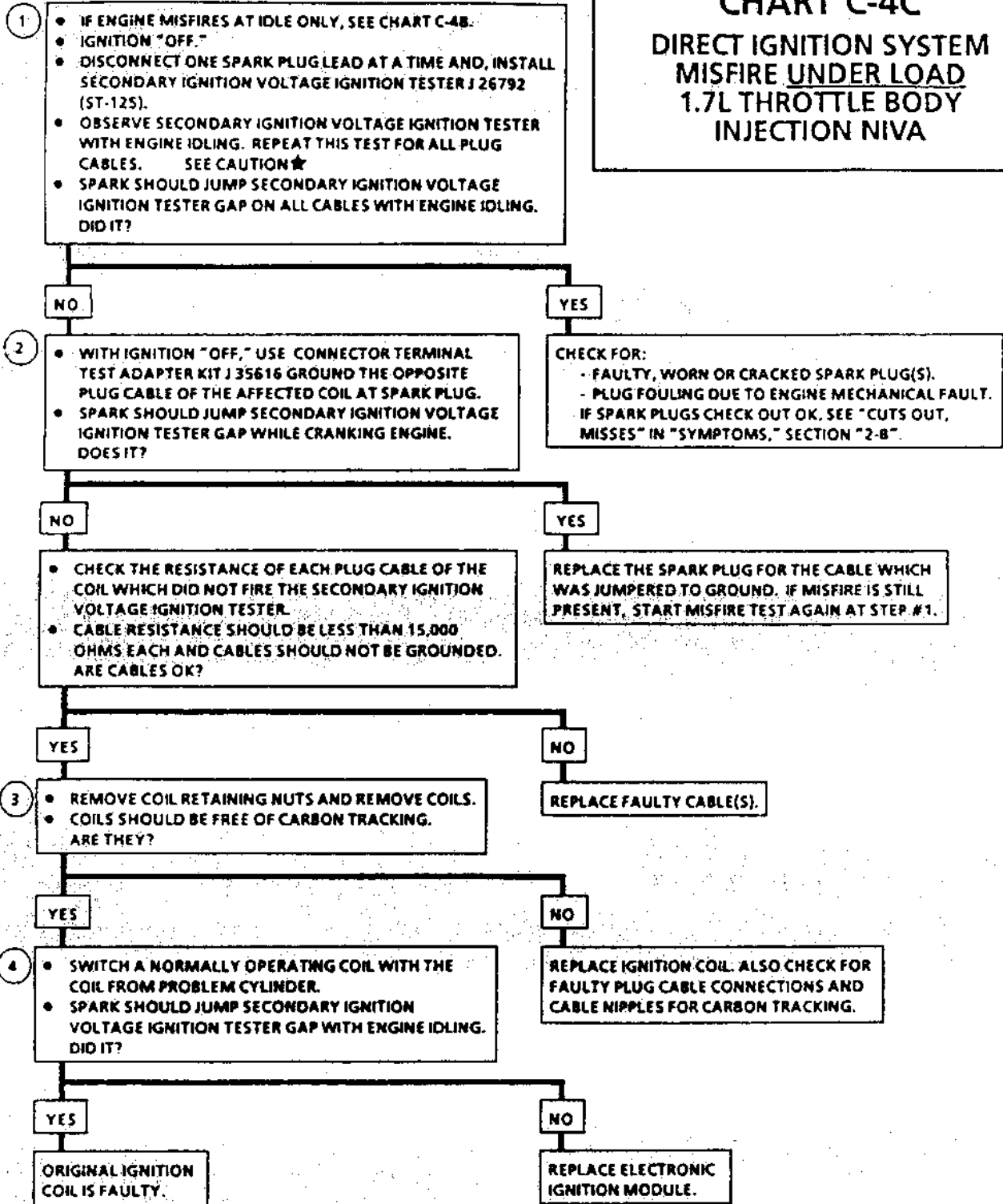

★ **CAUTION:** When handling secondary spark plug cables with engine running, insulated pliers must be used and care exercised to prevent a possible electrical shock.

"AFTER REPAIRS," START ENGINE, CLEAR CODES AND CONFIRM NO "CHECK ENGINE" LIGHT.

6-2-92  
 NS 14380

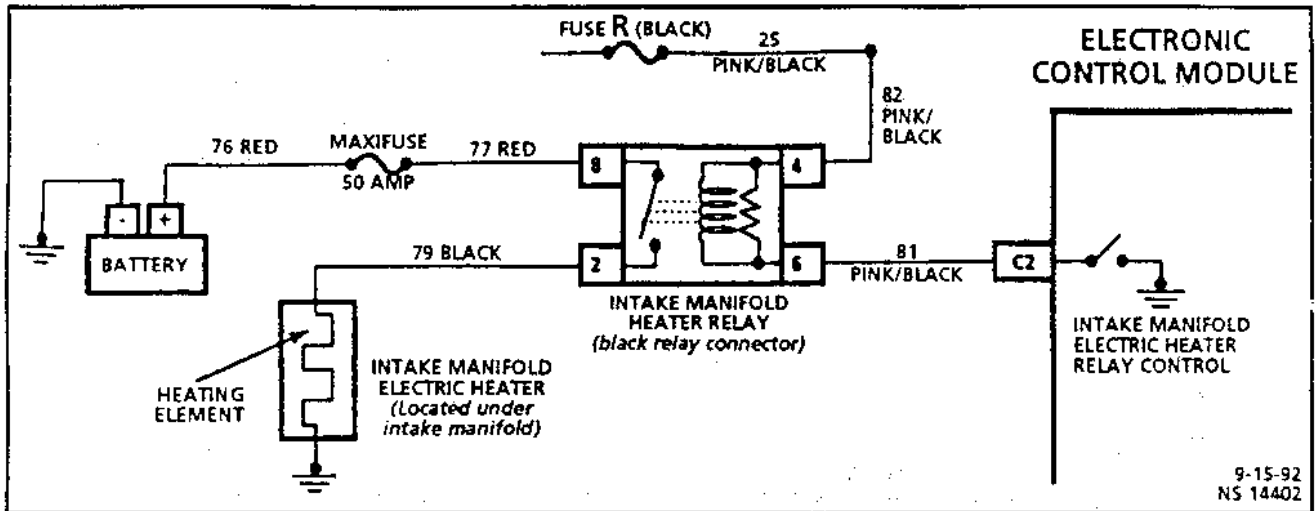

**CHART C-9**  
 (Page 1 of 2)  
**INTAKE MANIFOLD ELECTRIC HEATER**  
**1.7L THROTTLE BODY INJECTION NIVA**

**Circuit Description:**

To assist in cold driveability, the electronic control module controls a positive temperature coefficient heater. This electric heating element is turned "ON" by the electronic control module by supplying a ground to a control relay at the electronic control module's terminal "C2". The relay completes the circuit and supplies voltage from a 50 amp maxi fuse to the heater.

The heating element is self-current limiting, as its temperature increases its resistance increases, preventing thermal overheat and possible resultant short to ground.

The electronic control module switches "ON" the heater based upon various inputs and conditions:

- Coolant temperature sensor is less than 63°C.
- Engine is running.
- Intake air temperature is less than 80°C.
- Battery voltage is greater than 8 volts.

Once the heater has been "ON" the electronic control module will turn it "OFF," if the following conditions exist:

- Battery voltage is less than 6 volts. (Heavy electrical accessory load.)
- Coolant temperature sensor input is greater than 65°C.

**Test Description:** Numbers below refer to circled numbers on the diagnostic chart.

1. By using the Tech 1 "Scan" tool this quick check of the intake manifold heater can be performed. (See Diagnostic Aids.)
2. This step checks for power on relay control and load circuits.

**Diagnostic Aids:**

With ignition "ON," engine running, use Tech 1 "OUTPUT TEST" to turn "ON" heater. Observe "System Voltage" on Tech 1. System voltage should drop at least 0.3 volts with heater "ON." Engine must be idling for this Tech 1 command to take effect.



### CHART C-9

(Page 1 of 2)

### INTAKE MANIFOLD ELECTRIC HEATER 1.7L THROTTLE BODY INJECTION NIVA

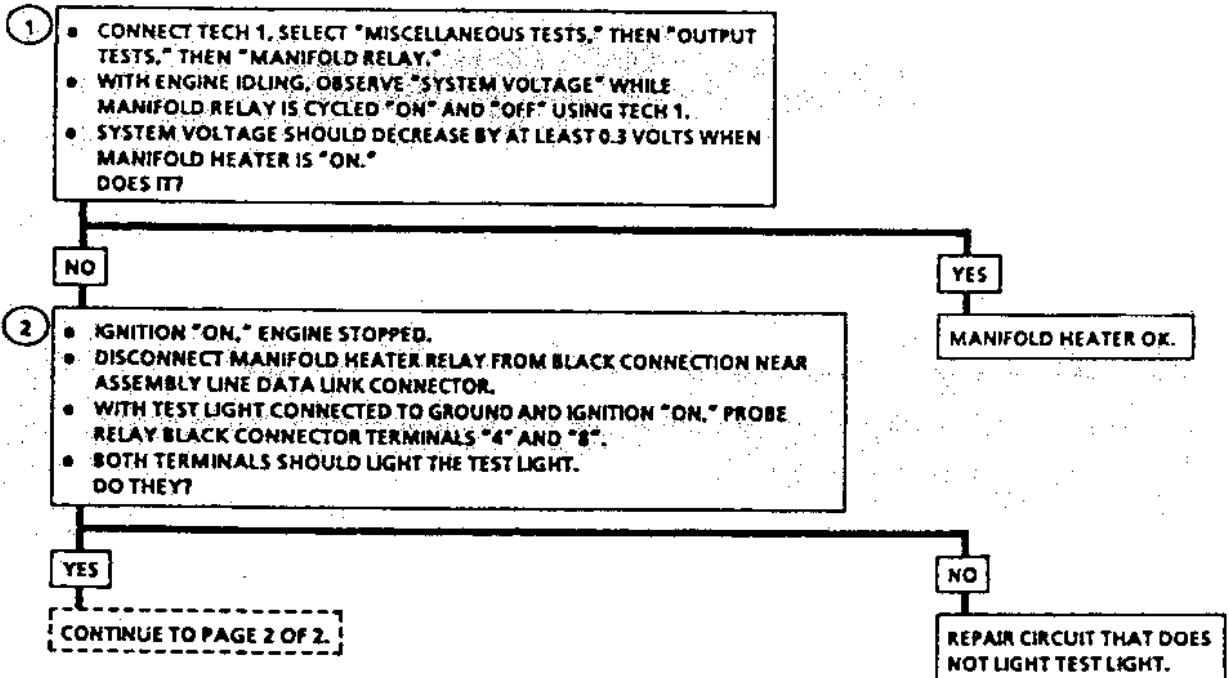

9-25-92  
NS 15805

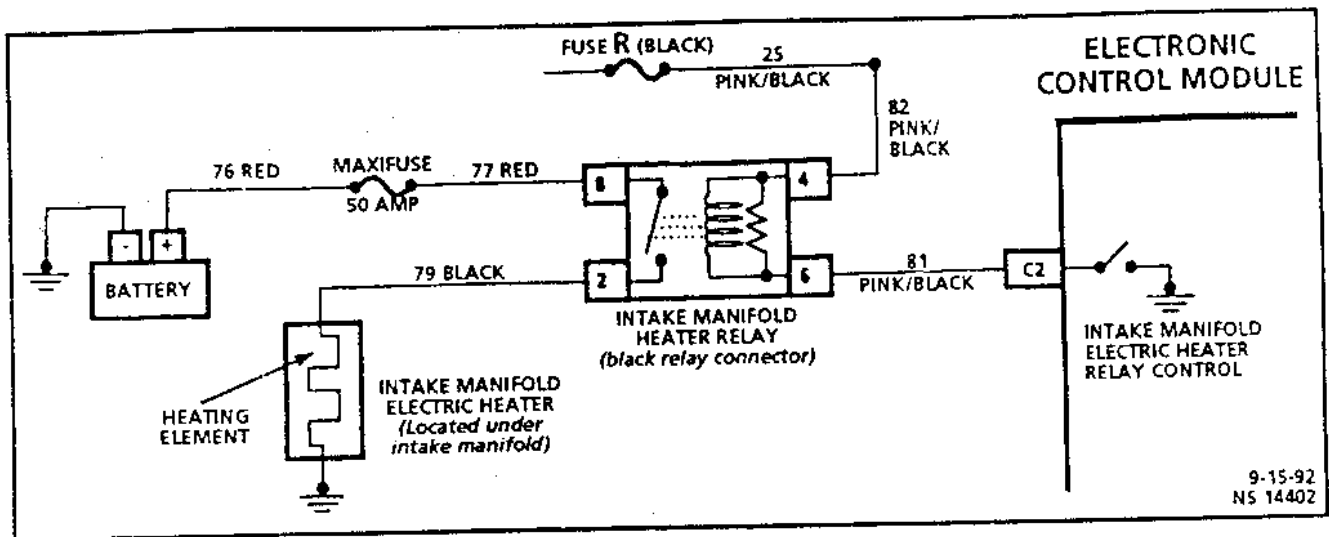

CHART C-9

(Page 2 of 2)

INTAKE MANIFOLD ELECTRIC HEATER  
1.7L THROTTLE BODY INJECTION NIVA

**Circuit Description:**

To assist in cold driveability, the electronic control module controls a positive temperature coefficient heater. This electric heating element is turned "ON" by the electronic control module by supplying a ground to a control relay at the electronic control module's terminal "C2". The relay completes the circuit and supplies voltage from a 50 amp maxi fuse to the heater.

The heating element is self-current limiting, as its temperature increases its resistance increases, preventing thermal overheat and possible resultant short to ground.

The electronic control module switches "ON" the heater based upon various inputs and conditions:

- Coolant temperature sensor is less than 63°C.
- Engine is running.
- Intake air temperature is less than 80°C.
- Battery voltage is greater than 8 volts.

Once the heater has been "ON" the electronic control module will turn it "OFF," if the following conditions exist:

- Battery voltage is less than 6 volts. (Heavy electrical accessory load.)
- Coolant temperature sensor input is greater than 65°C.

**Test Description:** Numbers below refer to circled numbers on the diagnostic chart.

3. Heater must be tested at or about 27°C. As the heater warms from 27°C its resistance increases. If necessary, remove and cool the heater. The heater's resistance at 27°C should be less than 0.3 ohms.
4. This step checks Circuit 79 wire.
5. This step simulates electronic control module control of relay.
6. This step will determine if the electronic control module is defective or if Circuit 81 is faulty.

**Diagnostic Aids:**

With ignition "ON," engine running, use Tech 1 "OUTPUT TEST" to turn "ON" heater. Observe "System Voltage" on Tech 1. System voltage should drop at least 0.3 volts with heater "ON." Engine must be idling for this Tech 1 command to take effect.

### CHART C-9

(Page 2 of 2)

### INTAKE MANIFOLD ELECTRIC HEATER 1.7L THROTTLE BODY INJECTION NIVA

CONTINUED FROM  
PAGE 1 OF 2

- 3
- DISCONNECT MANIFOLD HEATER ELECTRICAL CONNECTOR. PERFORM NEXT STEP WITH HEATER AT ROOM TEMPERATURE.
  - USING DIGITAL OHMMETER, MEASURE RESISTANCE FROM HEATER CONNECTOR TO ENGINE BLOCK. SHOULD BE BETWEEN 0.3 AND 0.5 OHMS. IS IT?

YES

NO

- 4
- IF REMOVED AT PREVIOUS STEP, REINSTALL HEATER INTO INTAKE MANIFOLD.
  - RECONNECT HEATER ELECTRICAL CONNECTOR.
  - USING DIGITAL OHMMETER, MEASURE RESISTANCES BETWEEN RELAY CONNECTOR TERMINAL "2" AND ENGINE BLOCK GROUND.
  - RESISTANCE SHOULD NOT BE ZERO AND SHOULD BE APPROXIMATELY THE SAME AS MEASURED IN STEP 3. WHAT IS THE RESISTANCE?

CHECK INTAKE MANIFOLD HEATER HOLD DOWN BOLTS FOR CORROSION. ALSO INSURE THAT THEY ARE TIGHT. RECHECK RESISTANCE. IF STILL OVER SPECIFICATION REPLACE INTAKE MANIFOLD HEATER. RECHECK RESISTANCE. IF STILL OVER SPECIFICATION REPLACE INTAKE MANIFOLD HEATER.

APPROXIMATELY SAME AS STEP 3

ALMOST ZERO OHMS

OPEN CIRCUIT, NO CONTINUITY

- 5
- CONNECT TEST LIGHT BETWEEN +12 VOLTS AND RELAY CONNECTOR TERMINAL "6".
  - ENGINE IDLING, USE TECH 1 "OUTPUT TEST" TO TURN "ON" MANIFOLD HEATER RELAY CONTROL FROM ELECTRONIC CONTROL MODULE.
  - TEST LIGHT SHOULD LIGHT. DOES IT?

REPAIR SHORT TO GROUND IN CIRCUIT 79 BLACK WIRE BETWEEN HEATER CONNECTOR AND RELAY CONNECTOR.

REPAIR OPEN CIRCUIT IN BLACK WIRE BETWEEN HEATER CONNECTOR AND BLACK RELAY CONNECTOR TERMINAL "2".

YES

NO

REPLACE RELAY WITH NEW RELAY AND RETEST AT STEP 1.

6

- CONNECT TEST LIGHT BETWEEN +12 VOLTS AND ELECTRONIC CONTROL MODULE TERMINAL "C2".
- ENGINE IDLING.
- USE TECH 1 "OUTPUT TEST" TO TURN "ON" AND "OFF" MANIFOLD HEATER RELAY CONTROL.
- TEST LIGHT SHOULD TURN "ON" AND "OFF." WHAT DOES TEST LIGHT DO?

TURNS "ON" AND "OFF"

STAYS "ON"

STAYS "OFF"

REPAIR OPEN CIRCUIT 80 PINK/BLACK WIRE, BETWEEN ELECTRONIC CONTROL MODULE AND RELAY CONNECTOR.

REPAIR SHORT TO GROUND IN CIRCUIT 80 PINK/BLACK WIRE BETWEEN ELECTRONIC CONTROL MODULE AND RELAY CONNECTOR.

REPLACE ELECTRONIC CONTROL MODULE.

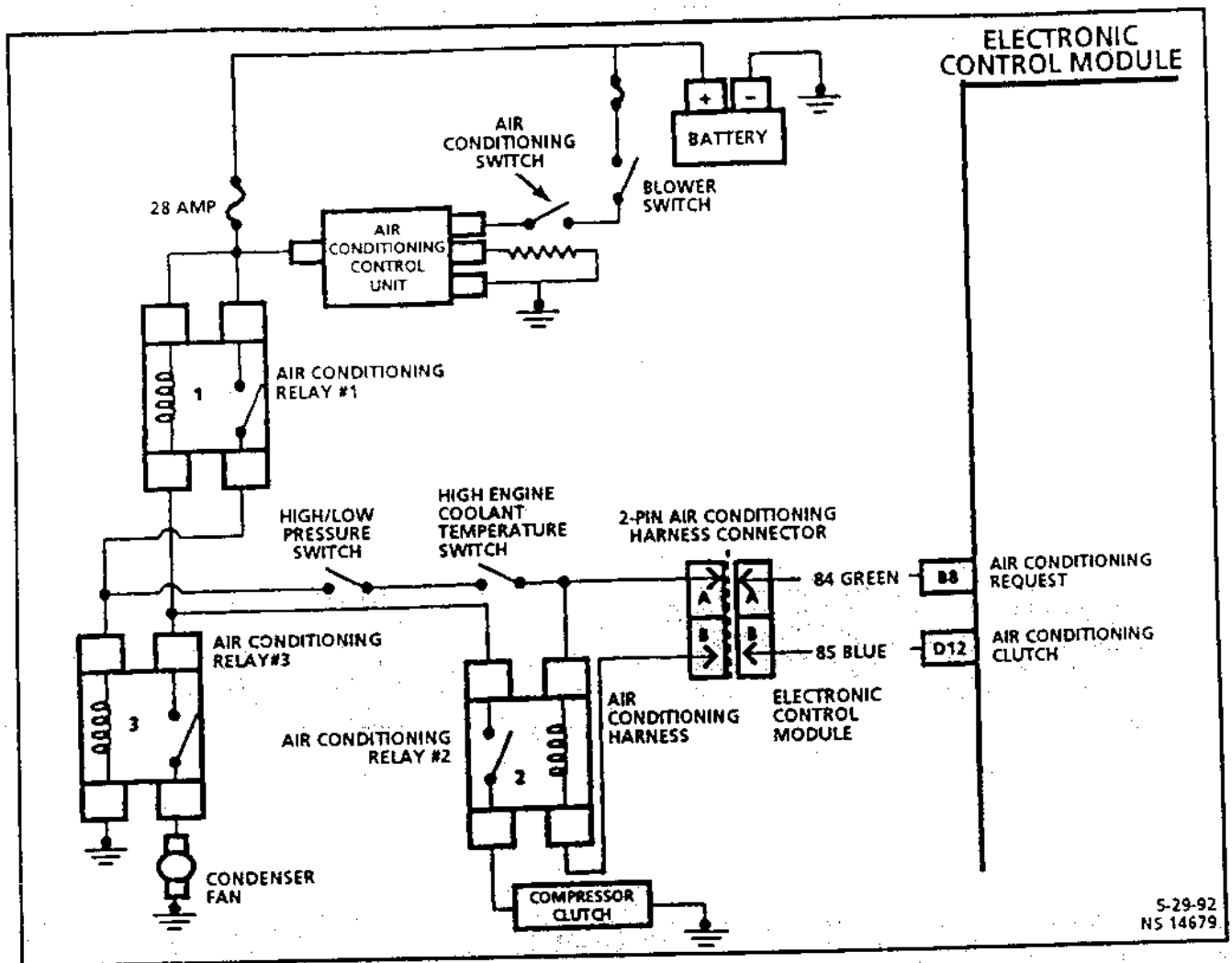

**CHART C-10**  
**AIR CONDITIONING COMPRESSOR CLUTCH CONTROL**  
**1.7L THROTTLE BODY INJECTION NIVA**

**Circuit Description:**

A request for air conditioning is sensed by the electronic control module. When it has + 12 volts applied to terminal "B8". When the electronic control module senses the air conditioning is requested, it will energize the air conditioning Compressor Clutch Control relay by providing a ground path for the coil part of the relay. The relay contacts will close, and current will flow from the relay and engage the air conditioning Compressor Clutch.

The electronic control module de-energizes the relay under the following conditions:

- If the throttle position sensor is greater than about 95%.
- No air conditioning requested.
- Coolant temperature is above about 112°C.
- Engine speed is above about 6375 revolutions per minute.
- Vehicle speed less than 7 km/h and throttle position greater than 50%.

**Test Description:** Number(s) below refer to circled number(s) on the diagnostic chart.

1. The air conditioning compressor clutch should not engage until about 0.3 second after the output test is enabled.
2. With engine idling and air conditioning dash switch "ON," the electronic control module should be grounding the relay control circuit causing the test light to be "ON."

**Diagnostic Aids:**

The Tech 1 "Scan" tool displays air conditioning request signal voltage at the electronic control module "B8".

A short to voltage on Circuit 84 Green wire to electronic control module terminal "B8" will display air conditioning request "Yes" in all positions of dash switch.

**CHART C-10**  
**AIR CONDITIONING COMPRESSOR**  
**CLUTCH CONTROL**  
**1.7L THROTTLE BODY INJECTION NIVA**

THIS CHART ASSUMES THE AIR  
 CONDITIONING SYSTEM IS FULLY CHARGED  
 AND IS IN PROPER WORKING CONDITION

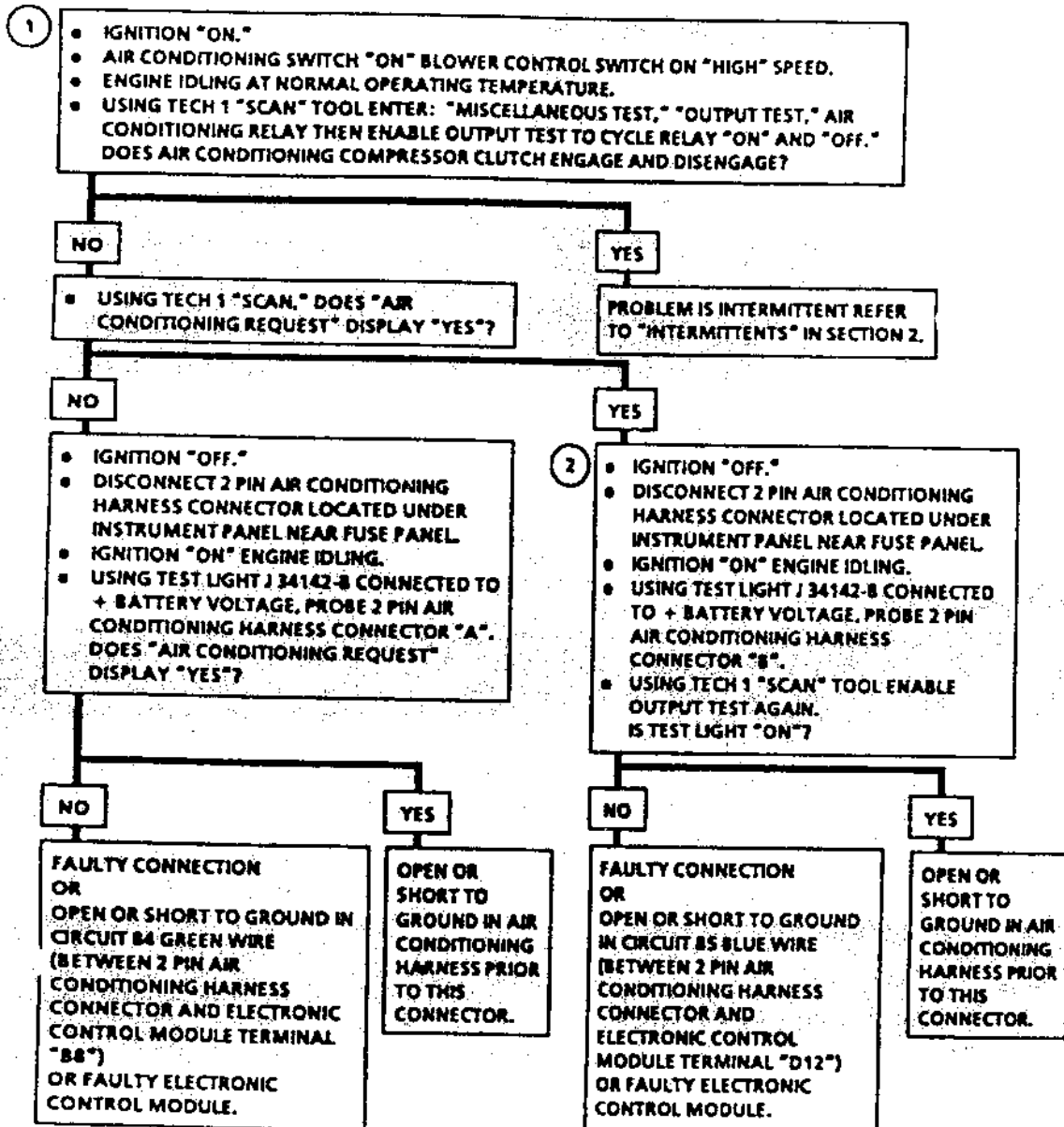

5-28-92  
 NS 14451

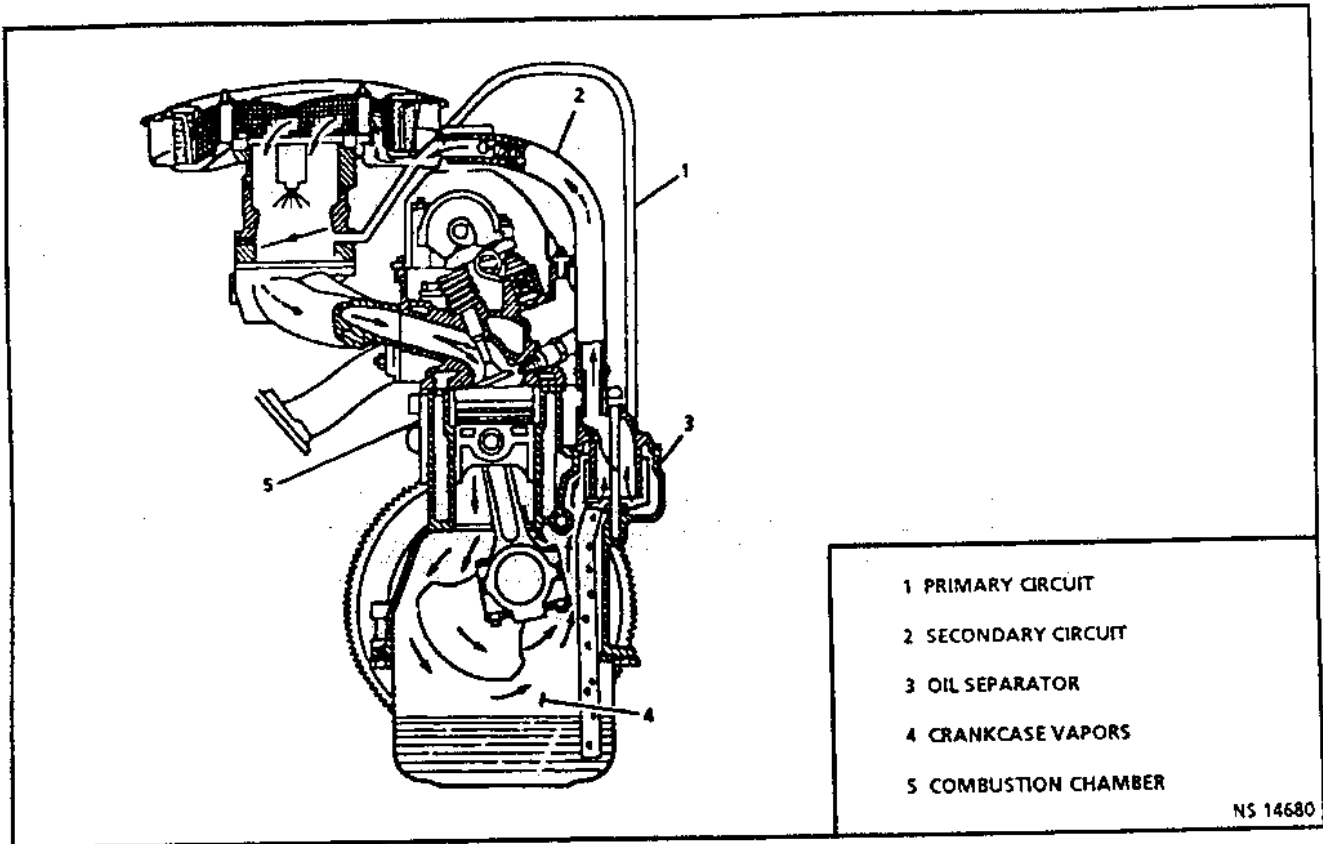

### CHART C-13

#### CRANKCASE VENTILATION SYSTEM CHECK 1.7L THROTTLE BODY INJECTION NIVA

##### System Description:

The crankcase ventilation system has 2 circuits. In both circuits crankcase vapors are returned to the combustion chamber through an oil separator located on the engine block near the ignition module. The primary circuit consists of a calibrated orifice fitted into the intake manifold just below the throttle body injection unit. A small hose runs from this orifice to the oil separator. A larger secondary circuit hose runs from the air cleaner to the oil separator.

At idle, all crankcase vapors are directed through the primary circuit orifice (small hose), which will be experiencing high vacuum. Under heavy load or wide open throttle conditions a small amount of crankcase vapors are passed through the primary system orifice. However, most vapors pass through the secondary system (large hose), into the air cleaner, through the throttle body injection and are burned in the combustion chamber.

##### RESULTS OF INCORRECT OPERATION:

A plugged hose may cause:

- Higher than normal idle air control steps.
- Oil leaks.
- Oil in air cleaner.
- Sludge in engine.

## CHART C-13

### CRANKCASE VENTILATION SYSTEM CHECK 1.7L THROTTLE BODY INJECTION NIVA

## DIAGNOSIS

### FUNCTIONAL CHECK OR VENTILATION SYSTEM

There are no moving parts in the ventilation system. Maintenance consists of inspecting the hoses to make sure they are clear and in good operating condition. The vacuum orifice in the manifold should be inspected on a regular basis to be sure it is not plugged, and cleaned if necessary.

Proper operation of the ventilation system is dependent upon a sealed engine. If oil sludging or dilution is noted, and the ventilation system is functioning properly, check engine for possible cause and correct to ensure that system will function as intended.

11-5-91  
MS 11545

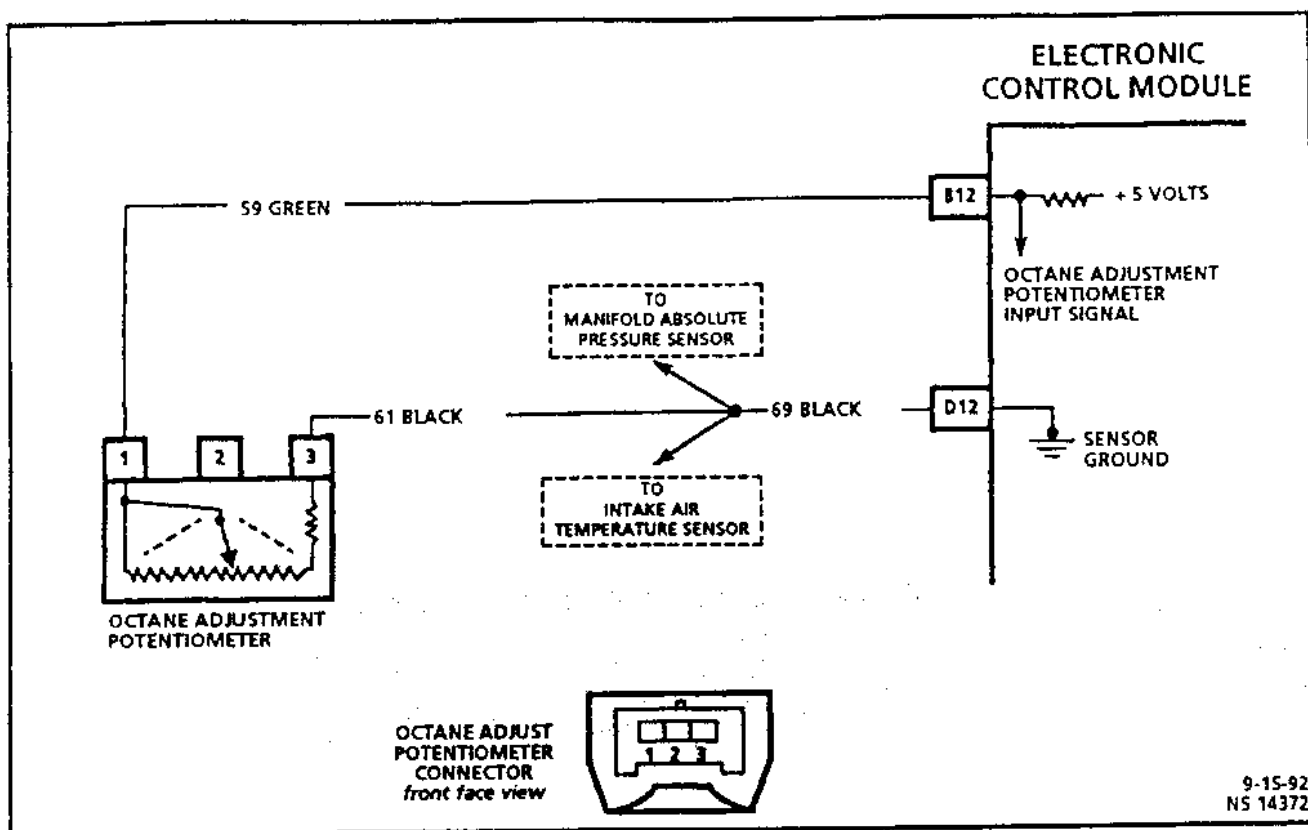

### CHART C-15

#### OCTANE ADJUSTMENT POTENTIOMETER CHECK 1.7L THROTTLE BODY INJECTION NIVA

##### System Description:

The octane adjustment potentiometer is a dealer only adjustment that compensates for the use of low octane fuel. The potentiometer is adjustable from about 1 to 4.5 volts and 0 to 8 degrees of retard. Any voltage adjustments that are made at the potentiometer provide a corresponding change in degrees of retard at the ignition system, provided the Tech 1 "Scan" tool is installed and in the "Octane Adjust" mode. Abnormally High (more than 4.9 volts) or abnormally low (less than 0.50 volts) voltage readings will cause a Code 54. While the Code 54 problem is present the "Check Engine" light will remain "ON" when the engine is running. At the same time, the electronic control module will use a substitute (value of "degrees of retard") until the problem is corrected.

No attempts at adjusting the Octane Adjust potentiometer should be made if a Code 54 is present.

**Test Description:** Number(s) below refer to circled number(s) on the diagnostic chart.

1. Checks to make sure a possible Code 54 is not set.
2. Checks operation of the potentiometer.
3. Describes adjustment procedures and precautions.

**NOTE:** The electronic control module monitors the voltage from the potentiometer any time the ignition is "ON." This can be observed using Tech 1 in the "F0: DATA LIST" mode when the engine is running.

However, changes to the amount of spark retard based on the potentiometer input signal will only take effect when the Tech 1 tool is used in the "Miscellaneous Tests-Octane Adjustment" mode.



## CHART C-15 OCTANE ADJUSTMENT POTENTIOMETER CHECK 1.7L THROTTLE BODY INJECTION NIVA

IF CODE 54 IS DETECTED, REPAIR THE PROBLEM THAT CAUSED THE CODE 54 BEFORE USING THIS PROCEDURE.

**NOTICE:** THE OCTANE ADJUST POTENTIOMETER IS PRESET AT THE FACTORY FOR THE USE OF HIGH OCTANE FUEL. IN MOST CASES IT WILL NOT NEED TO BE ADJUSTED DURING THE LIFE OF THE VEHICLE. THERE ARE ONLY TWO TIMES WHEN AN ADJUSTMENT SHOULD BE MADE:

1. IF THE CUSTOMER HAS COMPLAINED OF DETONATION.
2. IF THE CUSTOMER HAS REQUESTED AN ADJUSTMENT TO COMPENSATE FOR THE ANTICIPATED USE OF LOW OCTANE FUEL.

IF AN ADJUSTMENT IS BEING MADE FOR REASONS OTHER THAN THOSE LISTED ABOVE THEN THE ADJUSTMENT IS NOT NECESSARY AND YOU SHOULD NOT PROCEED WITH THIS CHART.

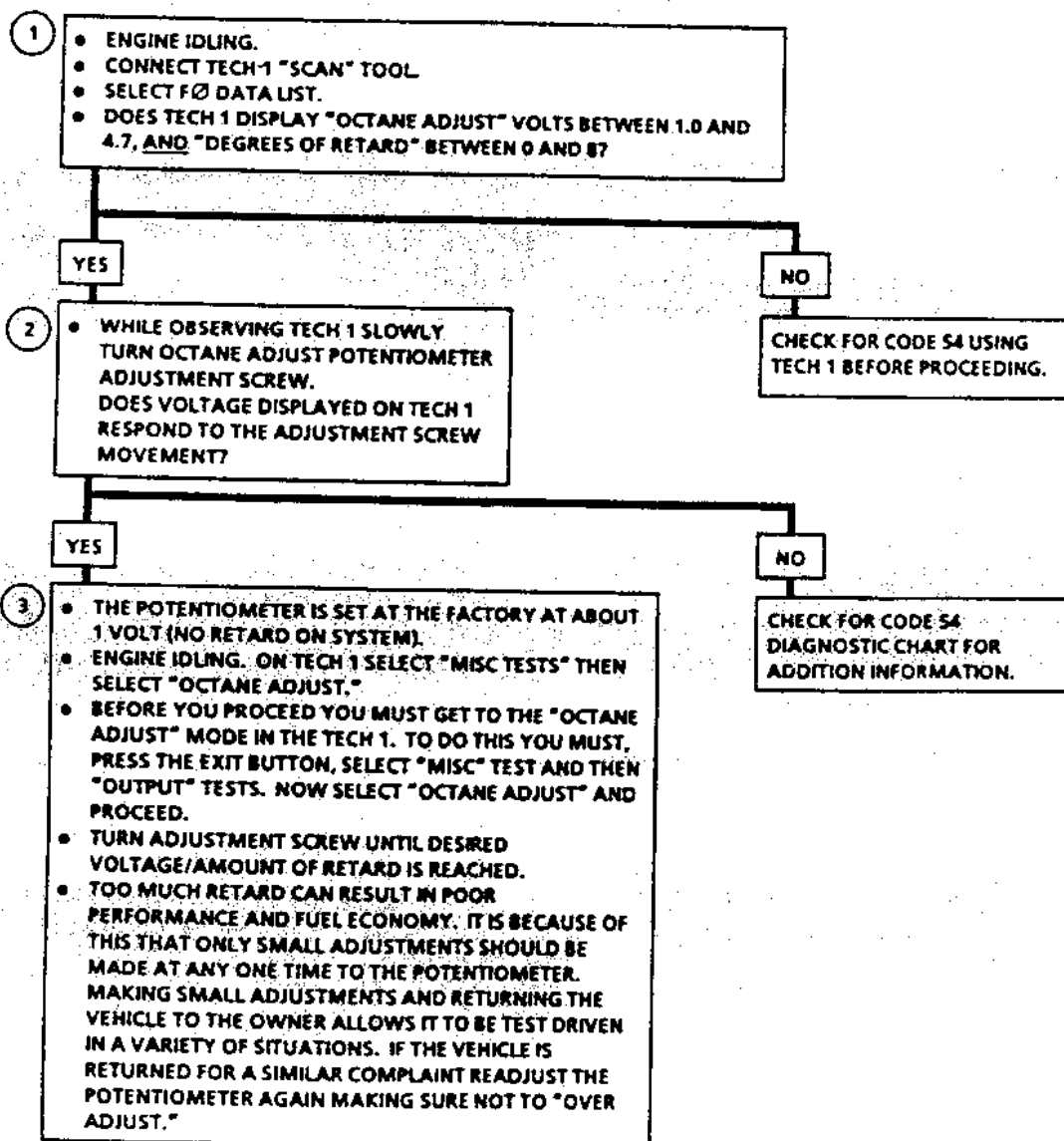

"AFTER REPAIRS," START ENGINE, CLEAR CODES AND CONFIRM NO "CHECK ENGINE" LIGHT.

2-8-93  
NS 15202

# **TURBONutter**

Lada Niva 4x4  
Service Manual  
Fuel Injection

This manual and a host of other wonderful Lada Niva documentation is available free of charge at:

<http://www.turbo-nutter.com>

You can do anything you like with this manual except sell it or otherwise make money from it.

While I can't stop you sticking it on your own website I would much prefer you linked to its original location on turbo-nutter.com

You use the information contained with this manual at you own risk. If you're not sure how to do something either don't do it or ask someone who knows about such things. The font of all Lada knowledge can be found at:

<http://www.lada.co.uk/forum>

For Lada parts, advice and general all round Lada wonderfulness these blokes aren't bad:

Lada UK Ltd  
Askew Rigg  
Troutbeck  
Penrith, Cumbria  
CA11 0SZ  
United Kingdom

T: +44 (0) 17 6877 9794  
F: +44 (0) 17 6877 9197  
E: [alan@lada.co.uk](mailto:alan@lada.co.uk)  
W: <http://www.lada.co.uk>

Lada Parts Australia P/L  
42 Aerodrome Road  
Caboolture  
Queensland  
4510  
Australia

T: +61 7 5495 5100  
F: +61 7 5495 5152  
E: [andy@ladaparts.com](mailto:andy@ladaparts.com)  
W: <http://www.ladaparts.com>

### 3. SERVICE OPERATIONS

**NOTICE:** When fasteners are removed, always reinstall them at the same location from which they were removed. If a fastener needs to be replaced, use the correct part number fastener for that application. If the correct part number fastener is not available, a fastener of equal size and strength (or stronger) may be used. Fasteners that are not reused, and those requiring thread locking compound will be called out. The correct torque value must be used when installing fasteners that require it. If the above conditions are not followed, parts of system damage could result.

#### SERVICE PRECAUTIONS

##### DRIVEABILITY AND EMISSIONS CONTROL

An electronic control module is designed to maintain exhaust emission levels at government standards while providing good driveability and fuel efficiency. The functions of the system are based on data gathered by sensors and switches located throughout the vehicle. The electronic control module maintains control over fuel delivery, ignition, idle air flow, the fuel pump and other system components, while monitoring the system for faulty operation with its diagnostic capabilities.

It is important to review the component sections and wiring diagrams to determine which systems are controlled by the electronic control module.

##### MAINTENANCE SCHEDULE

Refer to the Maintenance Schedule in the owner's handbook for the maintenance service that should be performed to retain performance.

##### BLOCKING DRIVE WHEELS

The vehicle drive wheels should always be blocked and parking brake firmly set while checking the system.

##### WHAT THIS SECTION CONTAINS

"Driveability and Emissions Service Operations," Section "3" describes the proper service procedures to repair components of the Engine Management system that controls the driveability and emissions of the vehicle. Emphasis is placed on the proper procedures and repair of components related to the system.

#### VISUAL/PHYSICAL UNDERHOOD INSPECTION

A careful visual and physical underhood inspection must be performed as part of any diagnostic procedure or in finding the cause of an emissions test failure. This can often lead to fixing a problem without further steps. Inspect all vacuum hoses for correct routing, pinches, cuts, or disconnects. Be sure to inspect hoses that are difficult to see beneath the air cleaner, compressor, alternator, etc. Inspect all the wires in the engine compartment for proper connections, burned or chafed spots, pinched wires, or contact with sharp edges or hot exhaust manifolds. This visual/physical inspection is very important. It must be done carefully and thoroughly.

#### SERVICE PRECAUTIONS

The following requirements must be observed when working on vehicles:

1. Before removing any electronic control module system component, disconnect the battery ground cable.
2. Never start the engine without the battery cables being solidly connected.
3. Never separate the battery from the on-board electrical system while the engine is running.
4. When charging the battery, disconnect it from the vehicle's electrical system.
5. Never subject the electronic control module to temperatures above 80°C i.e., paint oven. Always remove the electronic control module first if this temperature is to be exceeded.
6. Ensure that all cable harness plugs are connected solidly and that battery terminals are thoroughly clean.

## 3-2 ENGINE MANAGEMENT SYSTEMS 1.7L THROTTLE BODY INJECTION

7. The engine management system harness connectors are designed to fit only one way; there are indexing tabs and slots on both halves of the connector. Forcing the connector into place is not necessary if it is installed with the proper orientation. Failure to match the indexing tabs and slots on the connector can cause damage to the connector, the module, or other vehicle components or systems.
8. Never connect or disconnect the electronic control module connectors when the ignition is switched "ON."
9. Before attempting any electric arc welding on the vehicle, disconnect the battery leads and the electronic control module connectors.
10. When steam cleaning engines, do not direct the steam cleaning nozzle at electronic control module system components. If this happens, corrosion of the terminals can take place.
11. Use only the test equipment specified in the diagnostic charts, other test equipment may give incorrect results or damage good components.
12. Make all voltage measurements using a digital voltmeter with an internal impedance rating of at least 10 million ohms per volt.
13. When a test light is specified, a "low-power" test light must be used. Do not use a high wattage test light (i.e.: headlight). While a particular brand of test light is not suggested, a simple check of any test light will ensure it is safe for electronic control module circuit testing. Connect an accurate ammeter (such as the high-impedance digital multimeter) in series with the test light and power the test light-ammeter circuit with the vehicle battery.

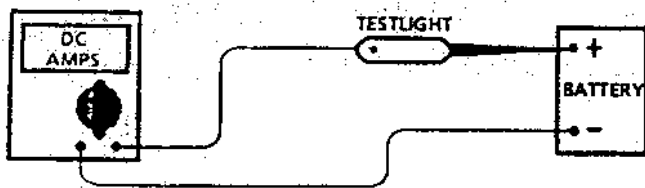

If the ammeter indicates **less** than 1/4 amp current flow (.25 A or 250 ma), the test light is **SAFE** to use.

If the ammeter indicates **more** than 1/4 amp current flow (.25 A or 250 ma), the test light is **NOT SAFE** to use.

### Electrostatic Discharge Damage

It is possible for less than 100 volts of static electricity to cause damage to some electronic components. Electronic components used in control systems are often designed to carry very low voltage, and are very susceptible to damage caused by electrostatic discharge. By comparison, it takes as much as 4,000 volts for a person to even feel the zap of a static discharge.

There are several ways for a person to become statically charged. The most common methods of charging are by friction and by induction. An example of charging by friction is a person sliding across a car seat where a charge of as much as 25,000 volts can build up. Charging by induction occurs when a person with well insulated shoes stands near a highly charged object and momentarily touches ground. Charges of the same polarity are drained off leaving the person highly charged with the opposite polarity. Static charges of either type can cause damage; therefore, it is important to use care when handling and testing electronic components.

**NOTICE:** To prevent possible Electrostatic Discharge damage:

- Do Not touch the electronic control module connector pins or soldered components on the electronic control module circuit board. Never disassemble the electronic control module metal case, except for the calibrator cover.
- When handling an engine calibrator, Do Not remove integrated circuit from carrier.

## REPAIR PROCEDURES

### ELECTRICAL REPAIRS

This part provides instruction in the following repairs:

- Circuit Protection.
- Typical Electrical Repairs.
- Replacing terminals on unsealed components.
- Replacing pigtails on sealed components.
- Replacing connector housings on unsealed components.
- Splicing Copper Wire.
- Splicing Twisted/Shielded Cable.
- Repairing Connectors (Except Weather Pack®).
- Repairing Weather Pack® (Environmental) Autofuse Connectors.
- Terminal Repair.

After any electrical repair is made, always test the circuit by operating the devices in the circuit. This confirms not only that the repair is correct, but also, that it was the cause of the complaint.

### CIRCUIT PROTECTION

The purpose of circuit protection is to protect the wiring assembly during normal and overload conditions. An overload is defined as a current requirement that is higher than normal. The overload could be caused by a short circuit or system malfunction. The short circuit could be the result of a pinched or cut wire, or an internal device short circuit, such as an electronic module failure.

The circuit protection device is only applied to protect the wiring assembly, and not the electrical load at the end of the assembly. For example, if an electronic component short circuits, the circuit protection device will assure a minimal amount of damage to the wiring assembly. However, it will not necessarily prevent damage to the component.

### CIRCUIT PROTECTION DEVICES

There are two basic types of circuit protection devices: Fuse, and Fusible Link.

### FUSES

The most common method of automotive wiring circuit protection is the fuse (Figure 3-1). A fuse is a device that, by the melting of its element, opens an electrical circuit when the current exceeds a given level for a sufficient time. The action is non-reversible and the fuse must be replaced each time a circuit is overloaded or after a malfunction is repaired.

Fuses are color coded. The standardized color identification and ratings are shown in Figure 3-2. For service replacement, non-color coded fuses of the same respective current rating can be used.

Examine a suspect fuse for a break in the element. If the element is broken or melted, replace the fuse with one of equal current rating.

There are additional specific circuits with in-line fuses. These fuses are located within the individual wiring harness and will appear to be an open circuit if blown.

### Autofuse

The Autofuse, normally referred to simply as "Fuse," is the most common circuit protection device in today's vehicle. The Autofuse is most often used to protect the wiring assembly between the Fuse Block and the system components.

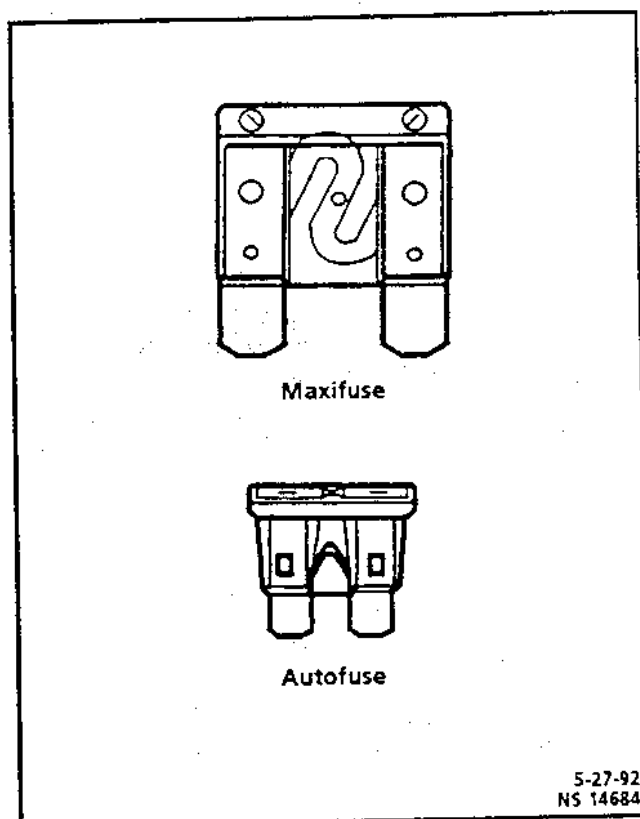

Figure 3-1 Fuse Devices

### Maxifuse

The Maxifuse was designed to replace the fusible link. The Maxifuse is designed to protect cables, normally between the Battery and Fuse Block, from both direct short circuits and resistive short circuits.

Compared to a fusible link, the Maxifuse performs much more like an Autofuse, although the average opening time is slightly longer. This is because the Maxifuse was designed to be a slower blowing fuse, with less chance of nuisance blows.

### Fusible Links

In addition to fuses, some circuits use fusible links to protect the wiring.

### 3-4 ENGINE MANAGEMENT SYSTEMS 1.7L THROTTLE BODY INJECTION

| AUTOFUSE       |         |
|----------------|---------|
| CURRENT RATING | COLOR   |
| 3              | VIOLET  |
| 5              | TAN     |
| 7.5            | BROWN   |
| 10             | RED     |
| 15             | BLUE    |
| 20             | YELLOW  |
| 25             | NATURAL |
| 30             | GREEN   |

| MAXIFUSE       |         |
|----------------|---------|
| CURRENT RATING | COLOR   |
| 20             | YELLOW  |
| 30             | GREEN   |
| 40             | AMBER   |
| 50             | RED     |
| 60             | BLUE    |
| 70             | BROWN   |
| 80             | NATURAL |

5-27-92  
MS 14685

Figure 3-2 Fuse Rating and Color

Like fuses, fusible links are "one-time" protection devices that will melt and create an open circuit (see Figure 3-3).

Not all fusible link open circuits can be detected by observation. Always inspect that there is battery voltage past the fusible link to verify continuity.

Each fusible link is four wire gauges smaller than the cable it is designed to protect.

Service fusible links are available in many lengths. Choose the shortest length that is suitable. If the fusible link is to be cut from a spool, it should be cut 150-225 mm long. NEVER make a fusible link longer than 225 mm.

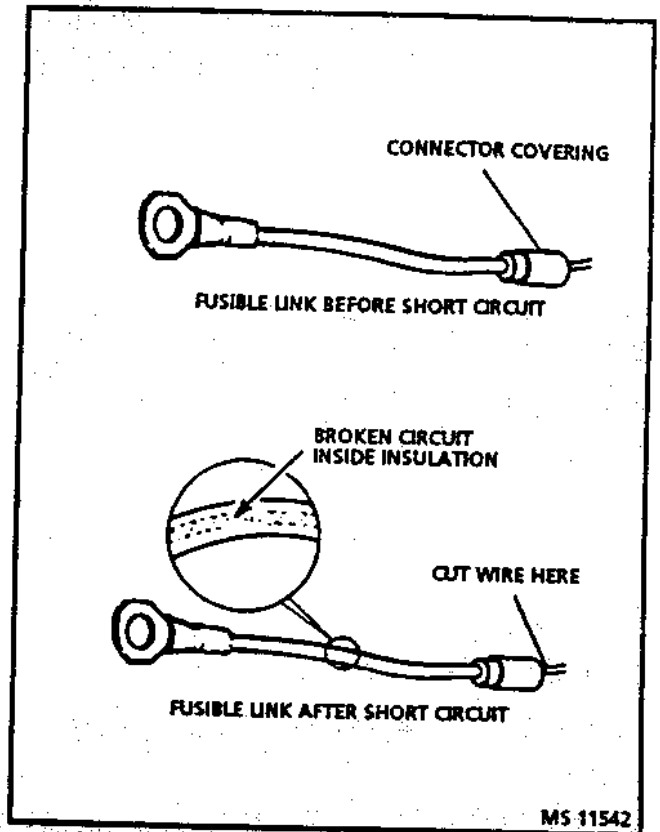

Figure 3-3 Good and Damaged Fusible Links

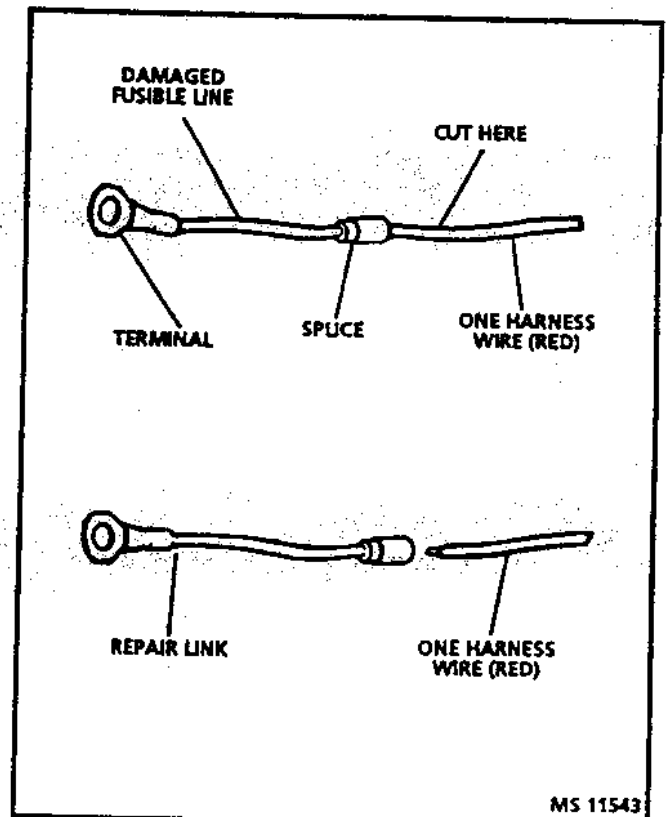

Figure 3-4 Single Wire Feed Fusible Link

**CAUTION:** Fusible links cut longer than 225 mm will not provide sufficient overload protection.

To replace a damaged fusible link (Figure 3-4), cut it off beyond the splice. Replace with a repair link. For splicing see "Splicing Copper Wire Using Splice Clips." To seal the splices do not use shrink tube with hot melt, there is special tubing required for fusible link applications. This special tubing is *not* included in Terminal Repair Kit J 39745. It is available, however, through Packard Electric and is referred to as "Heat Shrinking Dual Wall Tube." (ES M-2310 code 400, 500, 700.)

## TYPICAL ELECTRICAL REPAIRS

An open circuit is an incomplete circuit. Power cannot reach the load or reach ground. If a circuit is open, active components do not energize. A short circuit is an unwanted connection between one part of the circuit and either ground or another part of the circuit. A short circuit causes a fuse to blow.

### Short Circuits Caused By Damaged Wire Insulation

- Locate the damaged wire.
- Find and correct the cause of the wire insulation damage.

## REPLACING TERMINALS ON UNSEALED COMPONENTS

### Step 1:

Remove damaged terminal from the connector housing. To determine the correct removal tool to use, refer to the manual included in Terminal Repair Kit J 39745.

### Step 2:

Cut off damaged terminal. Do not cut off unnecessary amounts of wire. Cut off as little as possible.

### Step 3:

Remove wire insulation using the wire stripper provided in Terminal Repair Kit J 39745. Extreme caution must be used not to cut wire strands as the insulation is removed.

### Step 4:

Select the correct replacement terminal (refer to Terminal Repair Kit J 39745) and position the strip in the terminal.

### Step 5:

Using the correct crimp tool provided in Terminal Repair Kit J 39745, crimp the terminal. Solder all hand crimped terminals to ensure a clean, dry connection.

### Step 6:

Plug the terminal into the connector housing. Be sure that the wires are plugged into the correct cavity. A properly seated terminal will "Click" when seated.

## REPLACING PIGTAILS ON SEALED COMPONENTS

Pigtails are connectors with crimped wires. They are approximately 20 cm long. Pigtails are included in the Terminal Repair Kit J 39745 for all of the sealed components in the Engine Management System Wiring Harness.

### Repair Procedure

#### Step 1:

Select the correct pigtail using the manual included in Terminal Repair Kit J 39745.

#### Step 2:

Cut off the damaged connector *not more than 20 cm* from the top of the connector.

#### Step 3:

Splice the new pigtail into the harness. To make a sealed splice see "Splicing Copper Wire Using Splice Clips, Shrink Tube and Hot Melt," included in Section 3 of this manual.

Be sure that the color of the pigtail is the same color as the wire on the wiring harness.

All pigtails are marked with a white dot so that the replaced component can be identified for service reasons.

## 3-6 ENGINE MANAGEMENT SYSTEMS 1.7L THROTTLE BODY INJECTION

### Step 4:

If the sealed splices are not protected by conduit or tubing, wrap the splices with electrical tape to ensure a dry, clean connection.

### REPLACING CONNECTOR HOUSINGS ON UNSEALED COMPONENTS

#### Step 1:

Remove damaged terminals from the connector housing. To determine the correct removal tool to use, refer to the manual included in Terminal Repair Kit J 39745.

#### Step 2:

Select the correct connector housing using the manual included in Terminal Repair Kit J 39745 as a guide.

#### Step 3:

Making sure that the terminals are indexed correctly, plug the terminals into the selected connector housing. Ensure that the wires are plugged into the correct cavity. A properly seated terminal will "Click" when seated.

### SPLICING COPPER WIRE USING SPLICE CLIPS

Splice Clips are included in Terminal Repair Kit J 39745. The splice clip should only be used as a general purpose wire repair device.

It should only be used for applications in the passenger compartment that do not need special requirements such as moisture sealing.

#### Step 1: Open the Harness

If the harness is taped, remove the tape. If the harness has a black plastic conduit, simply pull out the desired wire.

#### Step 2: Cut the Wire

Begin by cutting as little wire off the harness as possible. You may need the extra length of the wire later if you decide to cut more wire off to change the location of a splice. You may have to adjust splice locations to make certain that each splice is at least 40 mm away from an outlet(s) and 65 mm from another splice.

#### Step 3: Strip the Insulation

When replacing a wire, use a wire of the same size as the original wire or larger. The schematics list wire size in metric units.

If you aren't sure of the wire size, start with the largest opening in the wire stripper and work down until a clean strip of the insulation is removed. Be careful to avoid nicking or cutting any of the wires.

#### Step 4: Crimp the Wires

Select the proper clip to secure the splice. To determine the proper clip size for the wire being spliced, see splice crimp matrix below.

| SPLICE CRIMP MATRIX     |                           |         |
|-------------------------|---------------------------|---------|
| SPLICE CLIP PART NUMBER | WIRE SIZE/MM <sup>2</sup> |         |
|                         | 1.0-2.49                  | 2.5-5.0 |
| 12064904                | x                         |         |
| 12064905                |                           | x       |

4-27-93  
NS 15697

Figure 3-5 Splice Crimp Matrix

To select the correct crimp tool consult the instructions included in the Terminal Repair Kit J 39745. Select the correct anvil on the crimper. On most crimpers your choice is limited to either a small or large anvil. Overlap the stripped wire ends and hold them between your thumb and forefinger as shown in Figure 3-6. Then, center the splice clip under the stripped wires and hold it in place.

- Open the crimping tool to its full width and rest one handle on a firm flat surface.
- Center the back of the splice clip on the proper anvil and close the crimping tool to the point where the former touches the wings of the clip.
- Make sure that the clip and wires are still in the correct position. Then, apply steady pressure until the crimping tool closes.



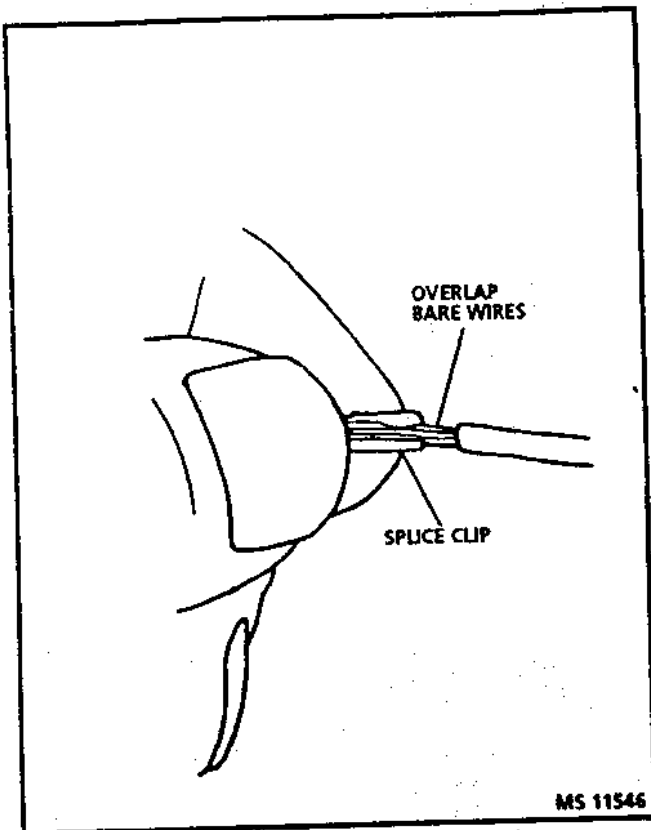

Figure 3-6 Centering the Splice Clip

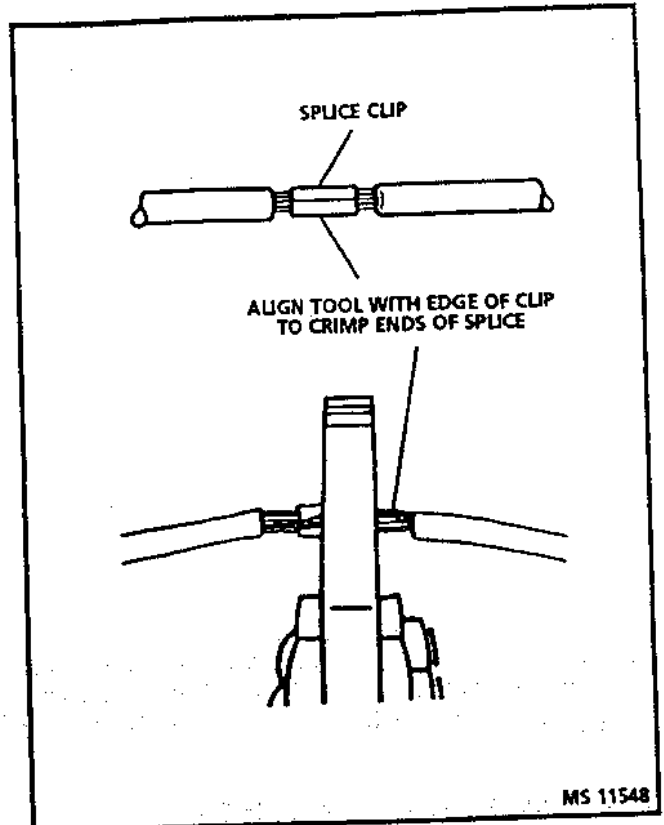

Figure 3-8 Completing the Crimp

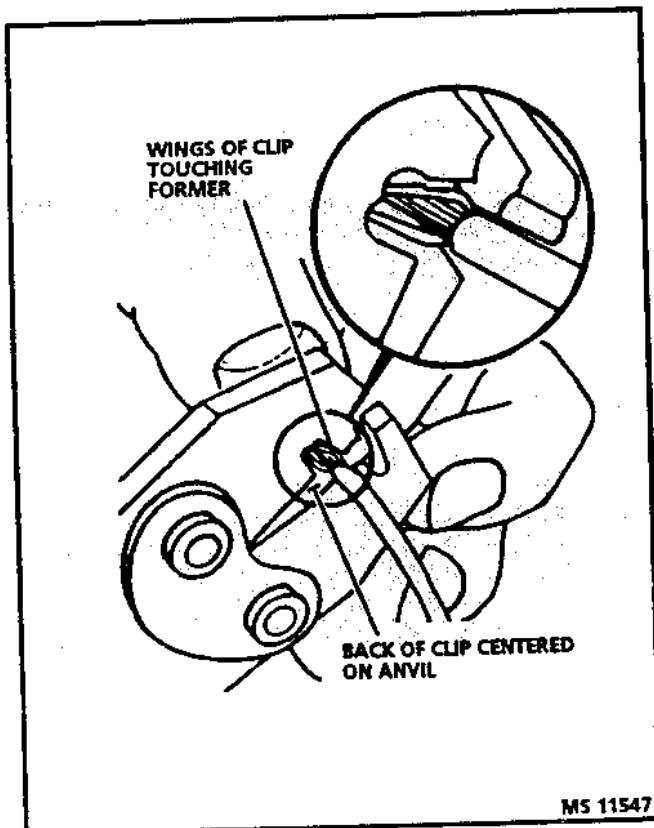

Figure 3-7 Crimping the Splice Clip

- Before crimping the ends of the clip, be sure that:
  - The wires extend beyond the clip in each direction.
  - No strands of wire are cut loose, and
  - No insulation is caught under the clip.

Crimp the splice again, once on each end. Do not let the crimping tool extend beyond the edge of the clip or you may damage or nick the wires (Figure 3-8).

#### Step 5: Solder

Apply 60/40 rosin core solder to the opening in the back of the clip (see Figure 3-9). Follow the manufacturer's instruction for the solder equipment you are using.

#### Step 6: Tape the Cable

Center and roll the splicing tape. The tape should cover the entire splice. Roll on enough tape to duplicate the thickness of the insulation on the existing wires. Do not flag the tape. Flagged tape may not provide enough insulation, and the flagged ends will tangle with the other wires in the harness (see Figure 3-10).

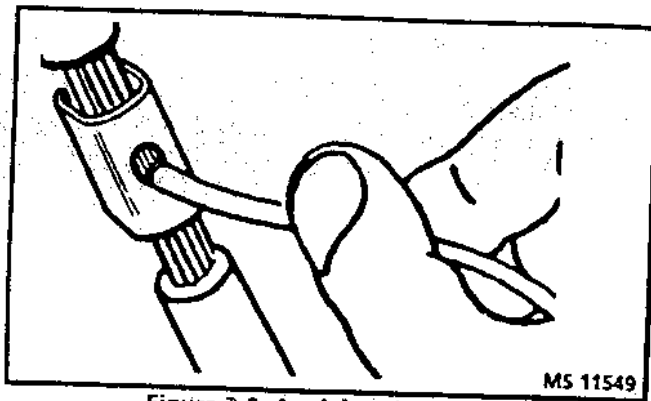

Figure 3-9 Applying the Solder

If the wire does not belong in a conduit or other harness covering, tape the wire again. Use a winding motion to cover the first piece of tape (Figure 3-11).

### SPlicing COPPER WIRE USING SPLICE CLIP, SHRINK TUBE AND HOT MELT

For applications in the engine compartment it is necessary to have sealed splices because of the potential of moisture invading the splice. Splice clips, shrink tube and hot melt are included in Terminal Repair Kit J 39745.

#### Step 1: Open the Harness

If the harness is taped, remove the tape. If the harness has a block plastic conduit, simply pull out the wire.

#### Step 2: Cut the Wire

Begin by cutting as little wire off the harness as possible. You may need the extra length of wire later if you decide to cut more wire to change the location of a splice. You may have to adjust splice locations to make certain that each splice is at least 40 mm away from an outlet(s) and 65 mm away from other splices.

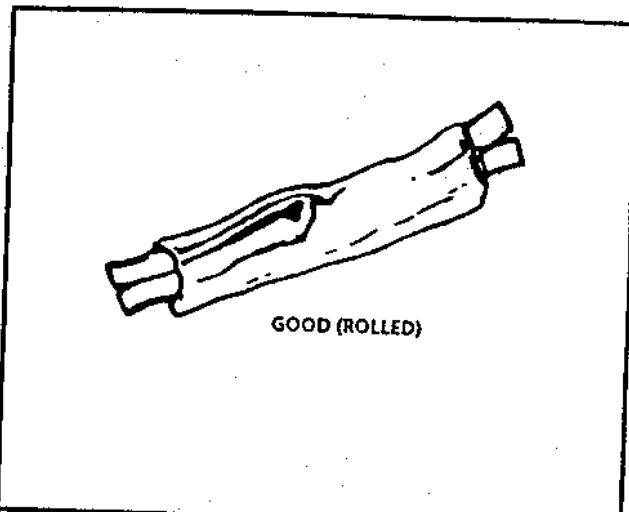

GOOD (ROLLED)

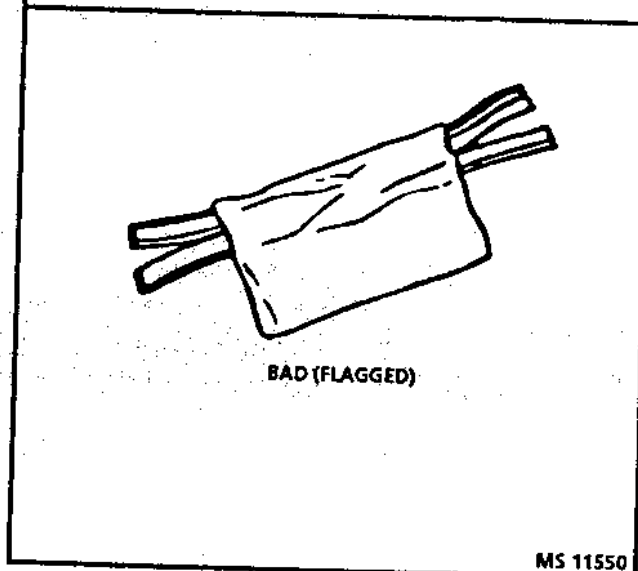

BAD (FLAGGED)

Figure 3-10 Proper First Taping

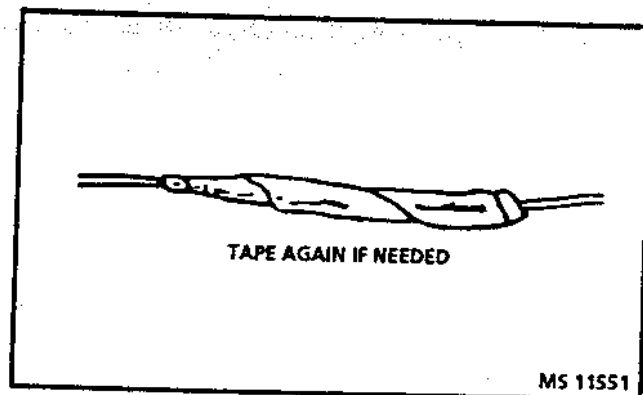

TAPE AGAIN IF NEEDED

MS 11551

Figure 3-11 Proper Second Taping

This will help prevent moisture from bridging adjacent splices and causing damage.

### Step 3: Strip the Insulation

When replacing a wire, use a wire of the same size as the original wire or larger. The schematics list wire size in metric units.

If you aren't sure of the wire size, start with the largest opening in the wire stripper and work down until a clean strip of the insulation is removed. Be careful to avoid nicking or cutting any of the wires.

### Step 4: Crimp the Wires

Remove the appropriate size shrink tube from Terminal Repair Kit J 39745 and slip it over the end of the wire. Select the proper clip to secure the splice. To determine the proper clip size for the wire being spliced, see splice crimp matrix below.

| <b>SPLICE CRIMP MATRIX</b> |                           |         |
|----------------------------|---------------------------|---------|
| SPLICE CLIP<br>PART NUMBER | WIRE SIZE/MM <sup>2</sup> |         |
|                            | 1.0-2.49                  | 2.5-5.0 |
| 12064904                   | x                         |         |
| 12064905                   |                           | x       |

4-27-83  
NS 15697

Figure 3-12 Splice Crimp Matrix

To select the correct crimp tool consult the instructions included in the Terminal repair kit J 39745. Select the correct anvil on the crimper. On most crimpers your choice is limited to either a small or large anvil. Overlap the stripped wire ends and hold them between your thumb and forefinger as shown in Figure 3-6. Then, center the splice clip under the stripped wires and hold it in place.

- Open the crimping tool to its full width and rest one handle on a firm flat surface.
- Center the back of the splice clip on the proper anvil and close the crimping tool to the point where the former touches the wings of the clip.
- Make sure that the clip and wires are still in the correct position. Then, apply steady pressure until the crimping tool closes.
- Before crimping the ends of the clip, be sure that:
  - The wires extend beyond the clip in each direction.
  - No strands of wire are cut loose, and
  - No insulation is caught under the clip.

Crimp the splice again, once on each end. Do not let the crimping tool extend beyond the edge of the clip or you may damage or nick the wires (Figure 3-8).

### Step 5: Solder

Apply 60/40 rosin core solder to the opening in the back of the clip (see Figure 3-9). Follow the manufacturer's instruction for the solder equipment you are using.

### 3-10 ENGINE MANAGEMENT SYSTEMS 1.7L THROTTLE BODY INJECTION

#### Step 6: Shrink Tube/Hot Melt

Shrink tube should now be applied to ensure that the splice remains clean and dry. Position the proper size shrink tube so that the splice clip and any bare copper wire is covered. Lay several pieces of hot melt under the shrink tube as close as possible to the middle of the splice. Shrink tube and hot melt are available in Terminal Repair Kit J 39745.

#### Step 7: Apply Heat

Using an appropriate low heat source, apply heat to the shrink tube. Be extremely careful not to position the heat source too close to the shrink tube, it will melt if overexposed to heat.

After a few seconds of moderate heat the shrink tube will melt and a small amount of hot melt will come out the end of the tube. The shrink tube will conform to the splice providing a clean, dry seal.

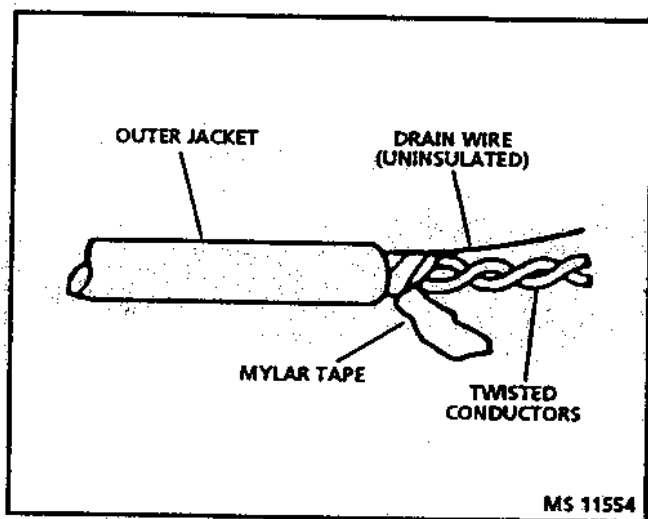

Figure 3-13 Twisted/Shielded Cable

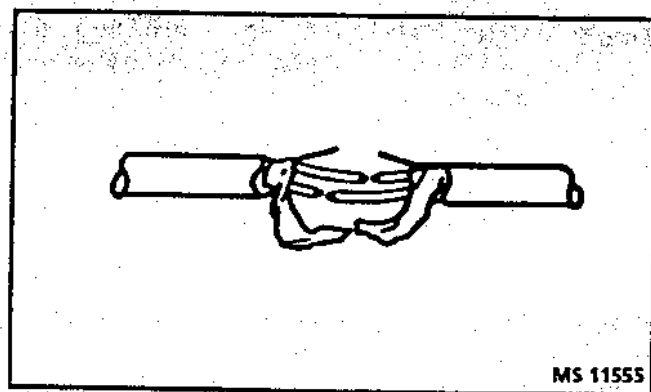

Figure 3-14 The Untwisted Conductors

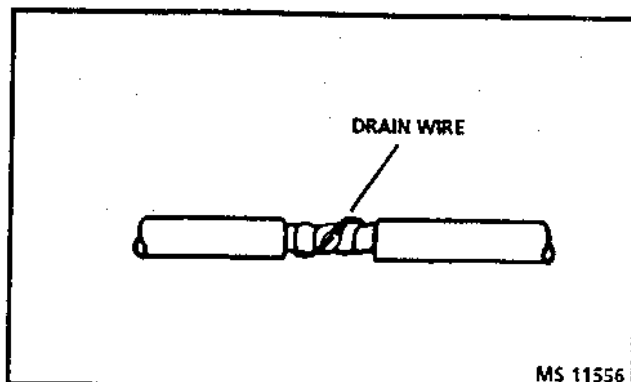

Figure 3-15 The Re-assembled Cable

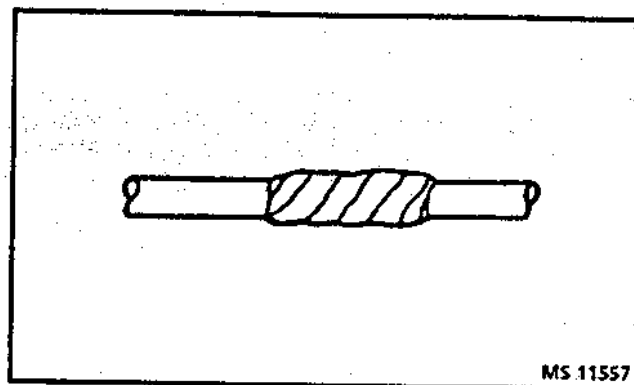

Figure 3-16 Proper Taping

#### SPlicing TWISTED/SHIELDED CABLE

Twisted/shielded cable is sometimes used to protect wiring from electrical noise (stray signals). For example, two-conductor cable of this construction is used between the electronic control module and the ignition module. See Figure 3-13 for a breakdown of twisted/shielded cable construction.

##### Step 1: Remove Outer Jacket

Remove the outer jacket and discard it. Be careful to avoid cutting into the drain wire or the mylar tape.

##### Step 2: Unwrap the Tape

Unwrap the aluminum/mylar tape, but do not remove it. The tape will be used to rewrap the twisted conductors after the splices have been made.

##### Step 3: Prepare the Splice

Untwist the conductors. Then, prepare the splice by following the splicing instructions for copper wire presented earlier. Remember to stagger splices to avoid shorts (Figure 3-14).

**Step 4: Re-assemble the Cable**

After you have spliced and taped each wire, rewrap the conductors with the mylar tape. Be careful to avoid wrapping the drain wire in the tape.

Next, splice the drain wire following the splicing instructions for copper wire. Then, wrap the drain wire around the conductors and mylar tape (Figure 3-15).

**Step 5: Tape the Cable**

Tape over the entire cable using a winding motion (see Figure 3-16). This tape will replace the section of the jacket you removed to make the repair.

**REPAIRING CONNECTORS**

- The following general repair procedures can be used to repair most types of connectors. The repair procedures are divided into three general groups: Push-to-Seat and Pull-to-Seat and Weather Pack®.
- See "Terminal Repair Kit Instruction Manual," (J 39745) to determine which type of connector is to be serviced.
- Use the proper Pick(s) or Tool(s) that apply to the terminal.

**PUSH-TO-SEAT AND PULL-TO-SEAT**

Follow the steps below to repair Push-to-Seat (Figure 3-17) or Pull-to-Seat (Figure 3-18) connectors. The steps are illustrated with typical connectors. Your connector may differ, but the repair steps are similar. Some connectors do not require all the steps shown. Skip those that don't apply.

- Step 1:** Remove any connector position assurance locks. Connector position assurances are designed to retain connectors when mated.
- Step 2:** Remove any terminal position assurance Locks. Terminal position assurances are designed to keep the terminal from backing out of the connector.
- NOTICE:** The terminal position assurance must be removed prior to terminal removal and must be replaced when the terminal is repaired and resealed.
- Step 3:** Open any secondary locks. A secondary lock aids in terminal retention and is usually molded to the connector.

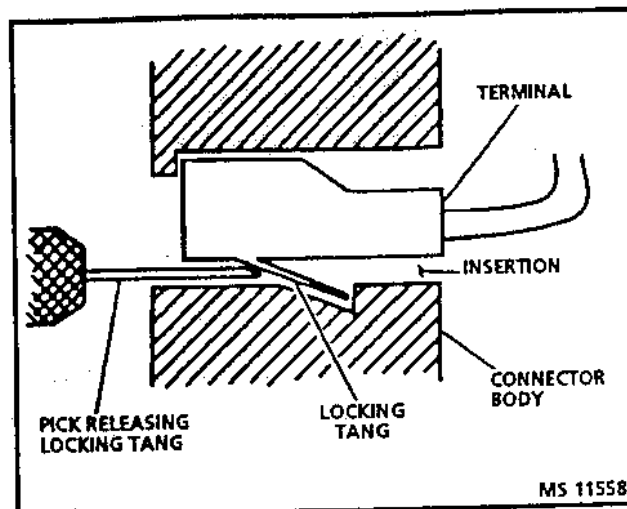

Figure 3-17 Typical Push-to-Seat Connector and Terminal

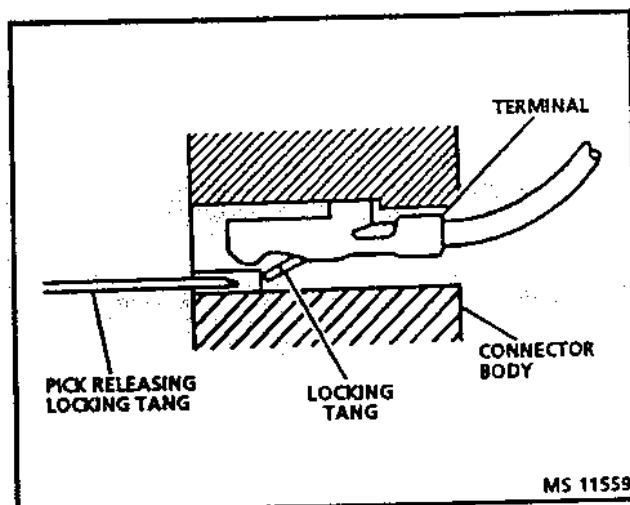

Figure 3-18 Typical Pull-to-Seat Connector and Terminal

- Step 4:** Separate the connector halves and back out seals.
- Step 5:** Grasp the lead and push the terminal to the forward most position. Hold the lead at this position.
- Step 6:** Locate the terminal lock tang in the connector canal.
- Step 7:** Insert the proper size pick (refer to Terminal Repair Kit J 39745) straight into the connector canal at the mating end of the connector.
- Step 8:** Depress the locking tang to unseat the terminal.

**Push-to-Seat -** Gently pull on the lead to remove the terminal through the back of the connector.

### 3-12 ENGINE MANAGEMENT SYSTEMS 1.7L THROTTLE BODY INJECTION

**Pull-to-Seat** - Gently push on the lead to remove the terminal through the front of the connector.

**NOTICE:** Never use force to remove a terminal from a connector.

- Step 9:** Inspect terminal and connector for damage. Repair as necessary.
- Step 10:** Reform lock tang and reseat terminal in connector body. Apply grease if connector was originally equipped with grease.
- Step 11:** Install any connector position assurances or terminal position assurances, close any secondary locks and join connector halves.

#### WEATHER PACK

Follow the steps below to repair Weather Pack® connectors (Figure 3-19).

- Step 1:** Separate the connector halves.
- Step 2:** Open secondary lock. A secondary lock aids in terminal retention and is usually molded to the connector.

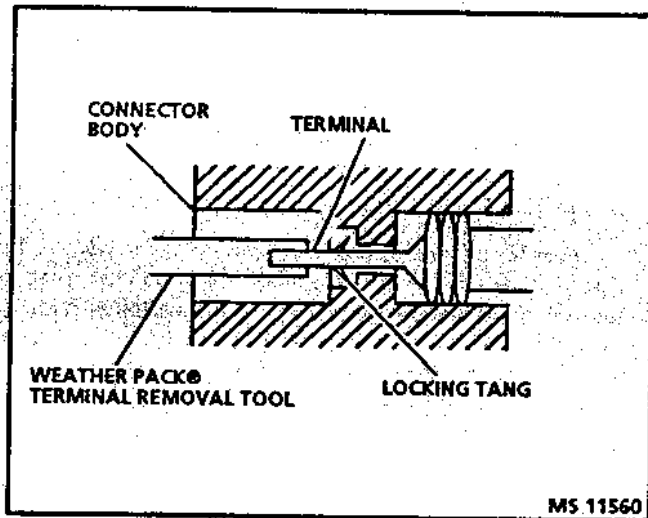

Figure 3-19 Typical Weather Pack® Connector and Terminal

- Step 3:** Grasp the lead and push the terminal to the forward most position. Hold the lead at this position.
- Step 4:** Insert the Weather Pack® terminal removal tool into the front (mating end) of the connector cavity until it rests on the cavity shoulder.
- Step 5:** Gently pull on the lead to remove the terminal through the back of the connector.  
**NOTICE:** Never use force to remove a terminal from a connector.
- Step 6:** Inspect the terminal and connector for damage. Repair as necessary (see "Terminal Repair," on following page).
- Step 7:** Reform the lock tang and reseat terminal in connector body.
- Step 8:** Close secondary locks and join connector halves.

#### TERMINAL REPAIR

The following repair procedures can be used to repair Push-to-Seat, Pull-to-Seat or Weather Pack® terminals (Figure 3-20). Some terminals do not require all steps shown. Skip those that don't apply. The Terminal Repair Kit (J 39745) contains additional information.

- Step 1:** Cut off terminal between core and insulation crimp (minimize wire loss) and remove seal for Weather Pack® terminals.
- Step 2:** Apply correct seal per gauge size of wire and slide back along wire to enable insulation removal (Weather Pack® terminals only).
- Step 3:** Remove insulation.
- Step 4:** Align seal with end of cable insulation (Weather Pack® terminals only).
- Step 5:** Position strip (and seal for Weather Pack®) in terminal.

- Step 6: Hand crimp core wings.
- Step 7: Hand crimp insulation wings (non-Weather Pack®). Hand crimp insulation wings around seal and cable (Weather Pack®).
- Step 8: Solder all hand crimped terminals.

### WIRING CONNECTOR SERVICE

Most connectors in the engine compartment are protected against moisture and dirt which could create oxidation and deposits on the terminals. This protection is important because of the very low voltage and current levels found in the electronic system. The connectors have a lock which secures the male and female terminals together. A secondary lock holds the seal and terminal into the connector.

When diagnosing, open circuits are often difficult to locate by sight because oxidation or terminal misalignment are hidden by the connectors. Merely wiggling a connector on a sensor or in the wiring harness may locate the open circuit condition.

This should always be considered when an open circuit or failed sensor is indicated. Intermittent problems may also be caused by oxidized or loose connections.

Before making a connector repair, be certain of the type of connector. Weather-Pack and Compact Three connectors look similar but are serviced differently.

### Metri-Pack Series 150 Terminals

Some electronic control module harness connectors contain terminals called Metri-Pack (see Figure 3-21). These are used at the coolant temperature sensor.

Metri-Pack terminals are also called "Pull-to-Seal" terminals because to install a terminal on a wire, the wire is first inserted through the seal and connector. The terminal is then crimped on the wire, and the terminal pulled back into the connector to seat it in place.

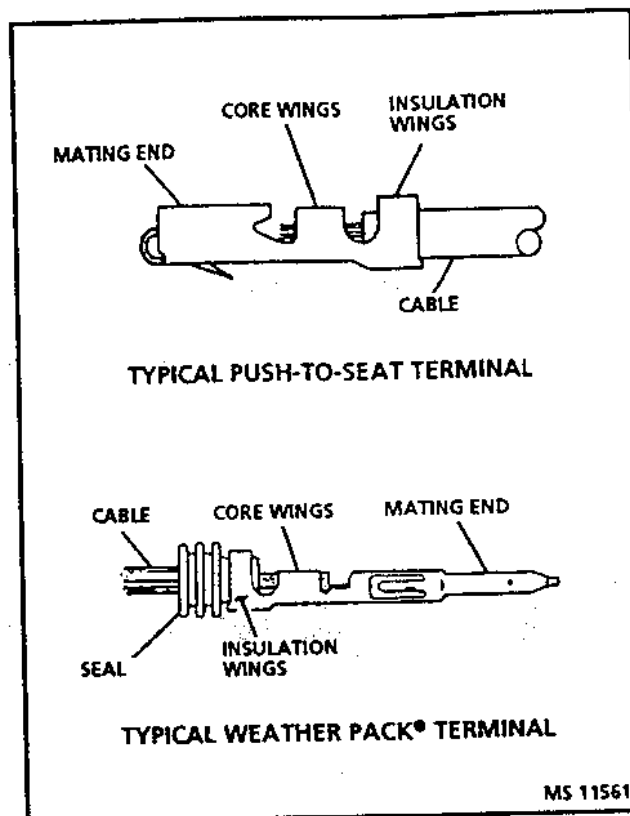

Figure 3-20 Terminal Repair

To remove a terminal:

1. Slide the seal back on the wire.
2. Insert tool as shown in Figure 3-21 insert "A", to release the terminal locking tang.

### Weather-Pack Connectors

Figure 3-22 shows a Weather-Pack connector and the tool required to service it. This tool is used to remove the pin and sleeve terminals. If terminal removal is attempted with an ordinary pick, there is a good chance that the terminal will be bent or deformed, and unlike standard blade type terminals, these terminals cannot be straightened once they are bent.

### 3-14 ENGINE MANAGEMENT SYSTEMS 1.7L THROTTLE BODY INJECTION

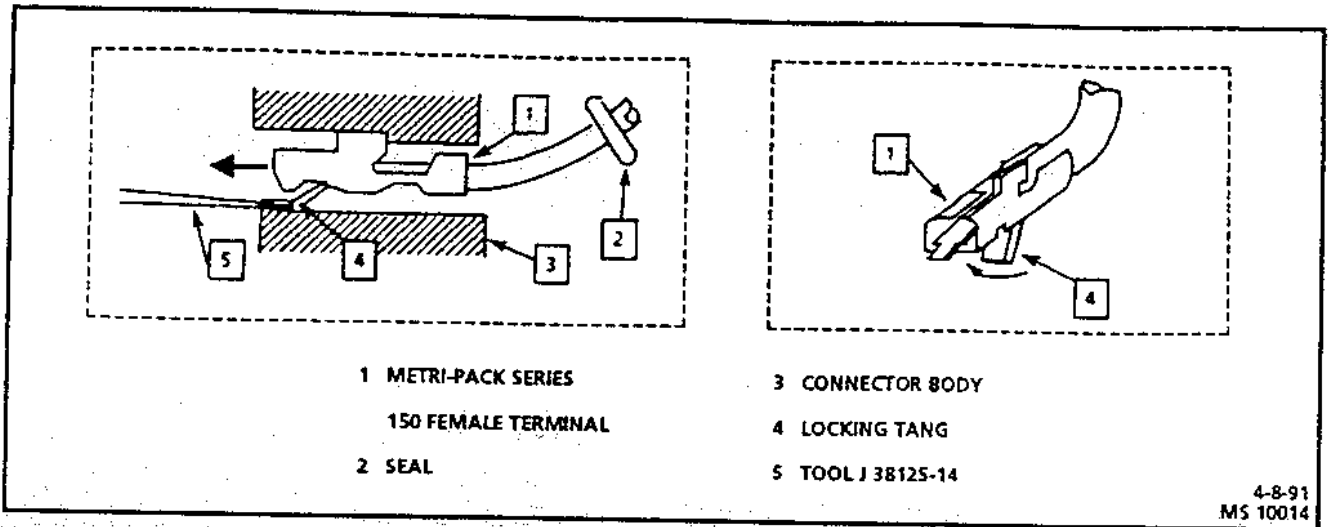

Figure 3-21 Metri-Pack Series 150 Terminal Removal

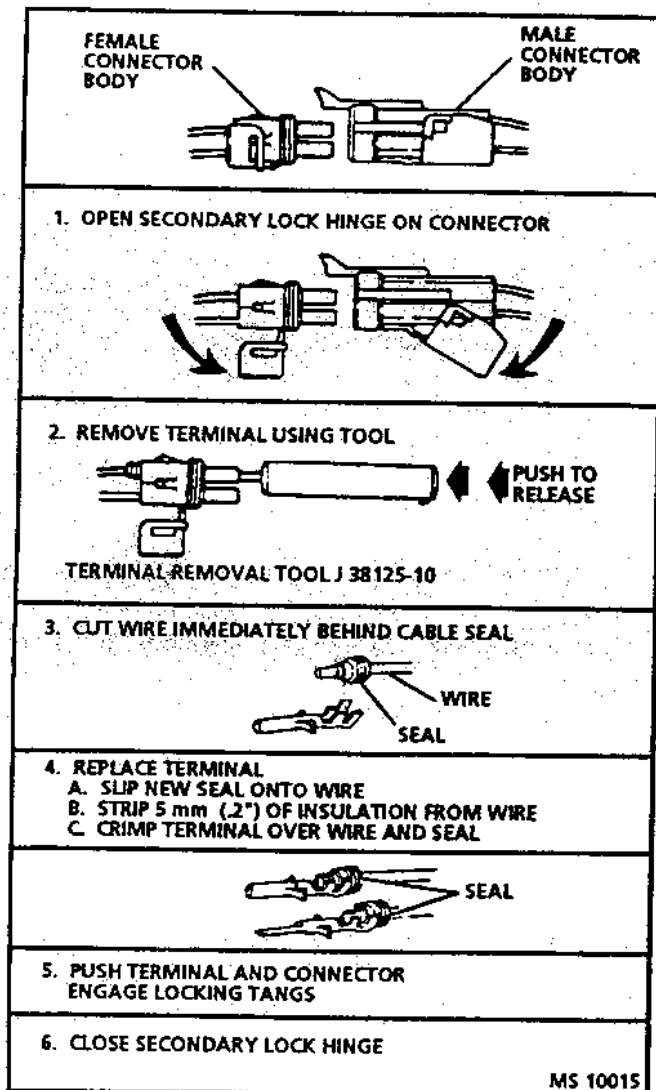

Figure 3-22 Weather-Pack Terminal Repair

Make certain that the connectors are properly seated and all of the sealing rings in place when connecting leads. The hinge-type flap provides a secondary locking feature for the connector. It improves the connector reliability by retaining the terminals if the small terminal lock tangs are not positioned properly.

Weather-Pack connections cannot be replaced with standard connections. Instructions are provided with Weather-Pack connector and terminal packages.

#### Compact Three Connectors

The Compact Three connector, which looks similar to a Weather-Pack connector, is not sealed and is used where resistance to the environment is not required. Use the standard method when repairing a terminal.

#### Micro-Pack Connectors

Micro-Pack terminal (see Figure 3-23) replacement requires the use of the special tool shown.

#### TOOLS NEEDED TO SERVICE THE SYSTEM

The system requires a Tech 1 "Scan" tool, test light, ohmmeter, digital voltmeter with 10 megohms impedance, vacuum gage and jumper wires for diagnosis. A test light or voltmeter must be used when specified in the procedures (Figure 3-24). See Section 6 - Special Tools needed to diagnose or repair a system. For more complete information on the operation of these tools, consult the tool manufacturer's instructions.



## WIRING HARNESS SERVICE

To meet GM engineering repair standards, use Terminal Repair Kit, J 39745, to repair wiring and replace connectors. The kit includes crimping tools, hardware, terminal removal tools, heat torch and instruction manual. Wire harnesses should be replaced with proper part number harnesses. When signal wires are spliced into a harness, use wire with high temperature insulation only. See Figure 3-25 for instructions.

With the low current and voltage levels found in the system, it is important that the best possible bond be made at all wire splices by soldering the splices as shown.

Use care when probing a connector or replacing connector terminals. It is possible to short between opposite terminals. If this happens, certain components can be damaged. Always use fused jumper wires between connectors for circuit checking. **NEVER** probe through connector seals, wire insulation, secondary ignition wires, boots, nipples, or covers. Even microscopic damage or holes may result in eventual water intrusion, corrosion and/or component or circuit failure.

## CHECKING TERMINAL CONTACT

When diagnosing an electrical system that utilizes Metri-Pack 150/280/480 series terminals (refer to Terminal Repair Kit J 39745 instruction manual for terminal identification), it is important to check terminal contact between a connector and component, or between in-line connectors, before replacing a suspect component. This is especially true for the Metri-Pack 150 series female terminal.

Frequently, a diagnostic chart leads to a step that reads: "Check for poor connection or replace...." Replacing a component may, at best, temporarily cure a connection problem. Eventually the connection will weaken and cause a repeat failure. Mating terminals must be inspected to assure good terminal contact or correct a poor connection. Poor connection between the male and female terminal at a connector is the result of contamination or deformation.

Contamination is caused by the connector halves being improperly joined, a missing or damaged connector seal, or damage to the connector itself, exposing the terminals to moisture and dirt. Contamination, usually to underhood or underbody connectors, leads to terminal corrosion, causing an open circuit or intermittently open circuit.

Deformation is caused by probing the mating side of a connector terminal without the proper adapter, improperly joining the connector halves or repeatedly separating and joining the connector halves. Deformation, usually to the female terminal contact tang, can result in poor terminal contact causing an open or intermittently open circuit.

Follow the procedure below to check terminal contact.

1. Separate the connector halves, refer to Terminal Repair Kit J 39745 instruction manual.
2. Inspect the connector halves for contamination. Contamination will result in a white or green build-up within the connector body or between terminals, causing high terminal resistance, intermittent connection or an open circuit. An underhood or underbody connector that shows signs of contamination should be replaced in its entirety, terminals, seals and connector body.
3. Using an equivalent male terminal from the Terminal Repair Kit J 39745, check the retention force of the female terminal in question by inserting and removing the male terminal to the female terminal in the connector body. Good terminal contact will require a certain amount of force to separate the terminals.
4. Using an equivalent female terminal from the Terminal Repair Kit J 39745, compare the retention force of this terminal to the female terminal in question by joining and separating the male terminal to the good female terminal, and then joining and separating the male terminal to the female terminal in question. If the retention force is significantly different between the two female terminals, replace the female terminal in question, refer to Terminal Repair Kit J 39745.
5. Push the wire and terminal out through the connector.

If the terminal is being reused, reshape the locking tang.

### 3-16. ENGINE MANAGEMENT SYSTEMS 1.7L THROTTLE BODY INJECTION

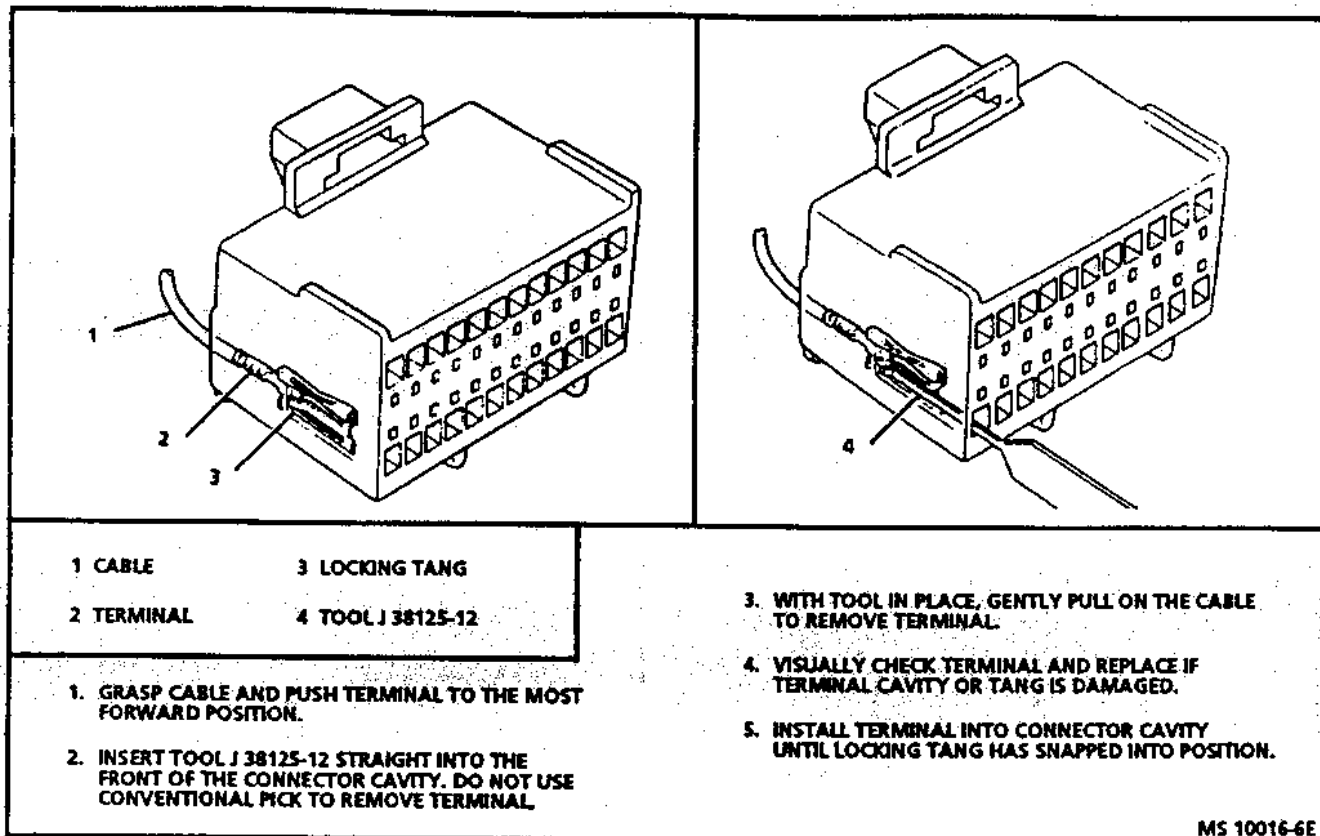

Figure 3-23 Micro-Pack Terminal Replacement

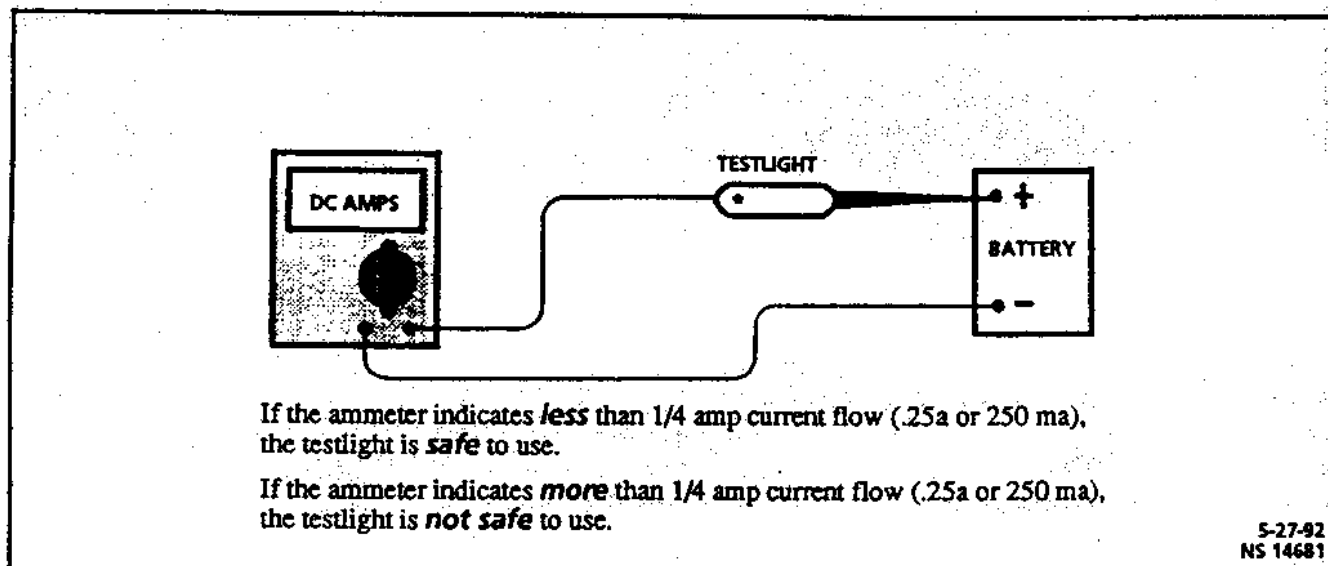

Figure 3-24 Test Light Check

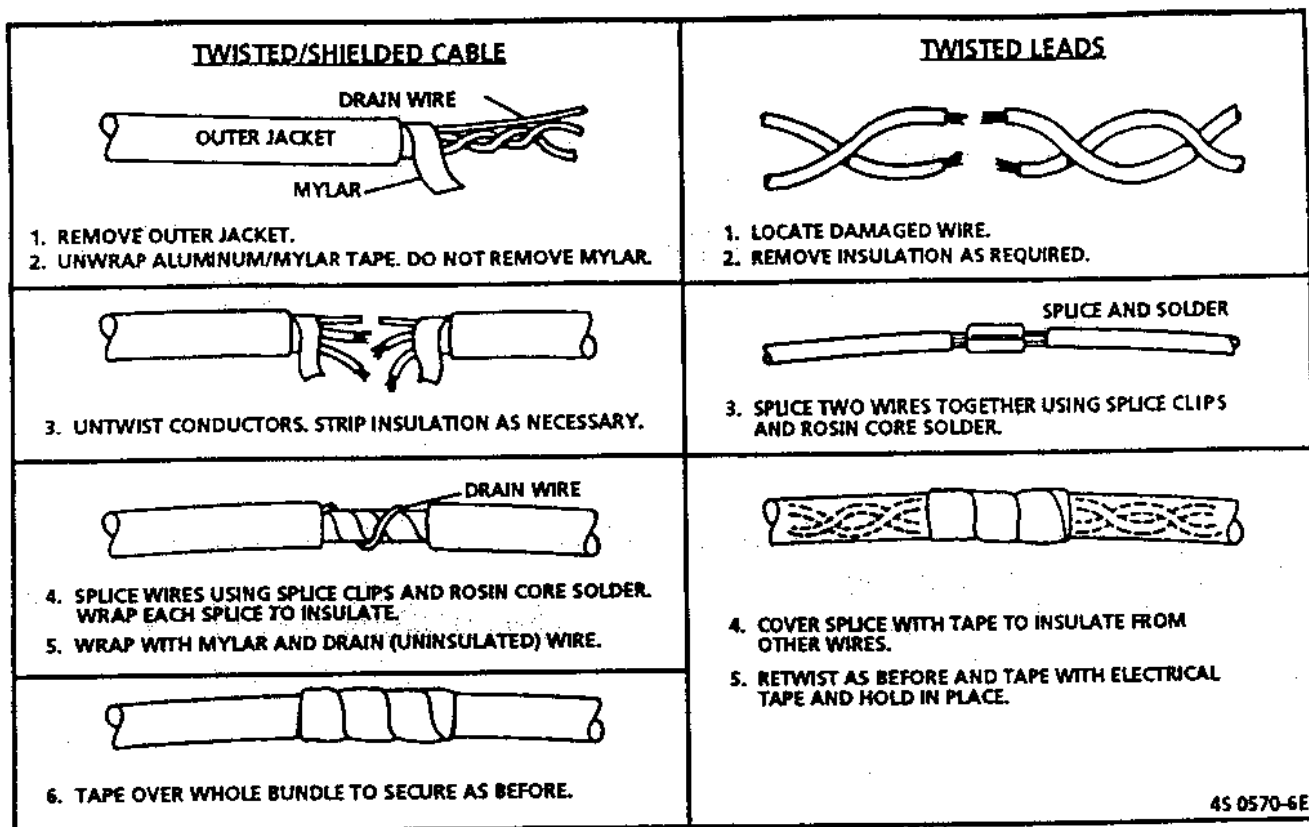

Figure 3-25 Wiring Harness Repair

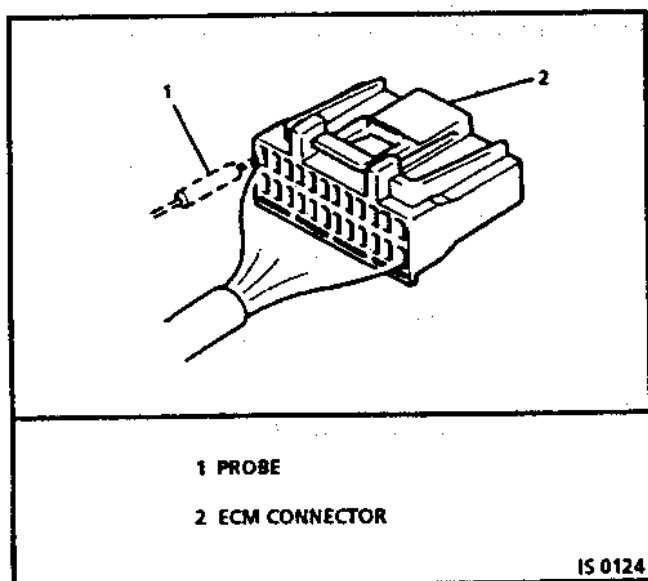

Figure 3-26 Electronic Control Module Terminal Probe Technique

### 3.1 ELECTRONIC CONTROL MODULE AND SENSORS

#### ELECTRONIC CONTROL MODULE

If the diagnostic procedures call for the electronic control module to be replaced, the engine calibrator and electronic control module should be checked first to see if they are the correct parts. If they are, remove the engine calibrator from the faulty electronic control module and install it in the new service electronic control module. THE SERVICE electronic control module WILL NOT CONTAIN AN engine calibrator. Code 61 indicates the engine calibrator is installed improperly or has malfunctioned. When Code 51 is obtained, check the engine calibrator installation for bent pins or pins not fully seated in the socket. If the engine calibrator is installed correctly and Code 51 still shows, replace the engine calibrator.

**LOCATION:** Driver's side of vehicle, behind kick panel.

#### Important

- When replacing the production electronic control module with a service electronic control module, it is important to transfer the calibrator identification and production electronic control module number to the service electronic control module label (see Figure 3.1-1). Please do not record on electronic control module cover. This will allow positive identification of electronic control module parts throughout the service life of the vehicle.

**NOTICE:** To prevent internal electronic control module damage, the ignition must be "OFF" when disconnecting or reconnecting power to electronic control module (for example, battery cable, electronic control module pigtail, electronic control module fuse, jumper cables, etc.).

#### Remove or Disconnect

1. Negative battery cable.
2. Driver's kick panel.
3. Electronic control module from bracket and connectors. (See Figure 3.1-2.)
4. Engine calibrator access cover. (See Figure 3.1-3.)
5. Engine calibrator from electronic control module.

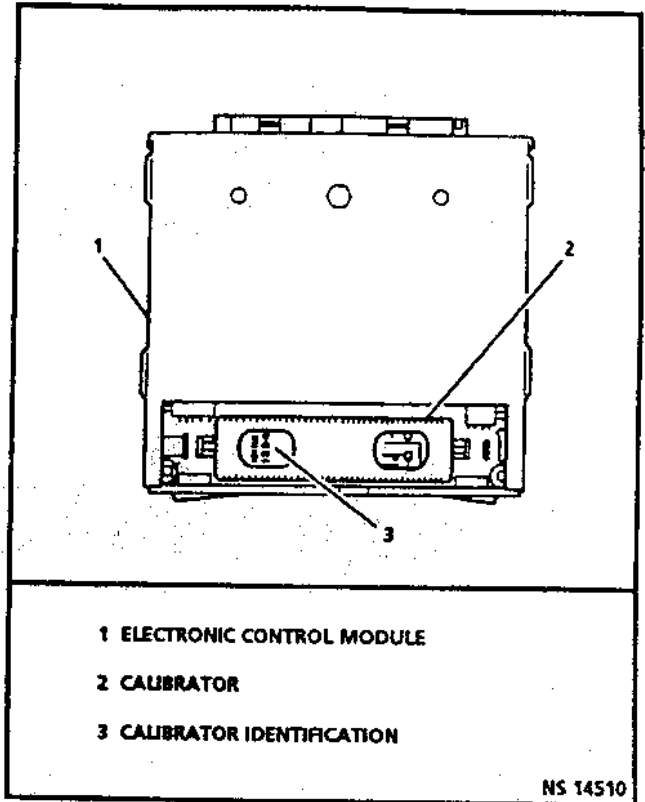

Figure 3.1-1 Calibrator Identification

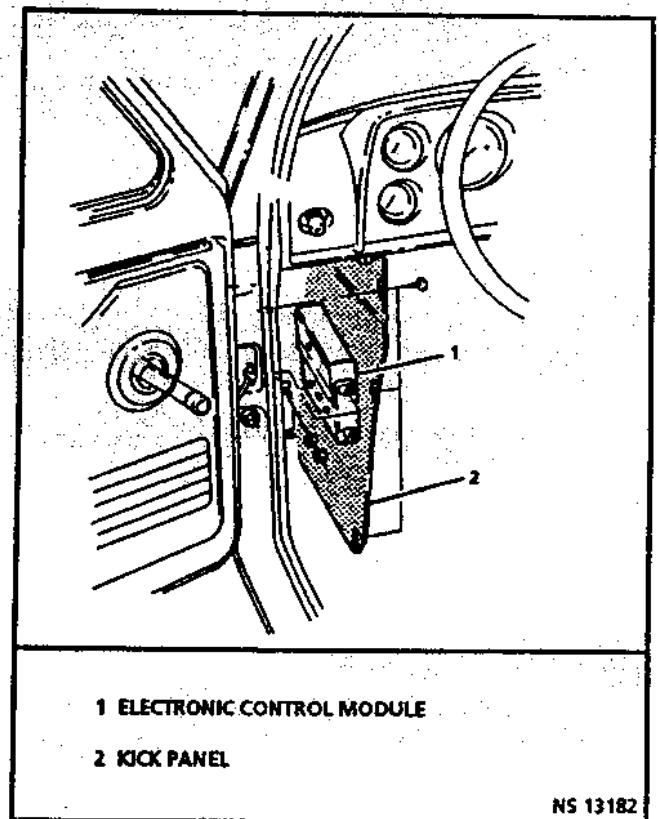

Figure 3.1-2 Electronic Control Module Location View

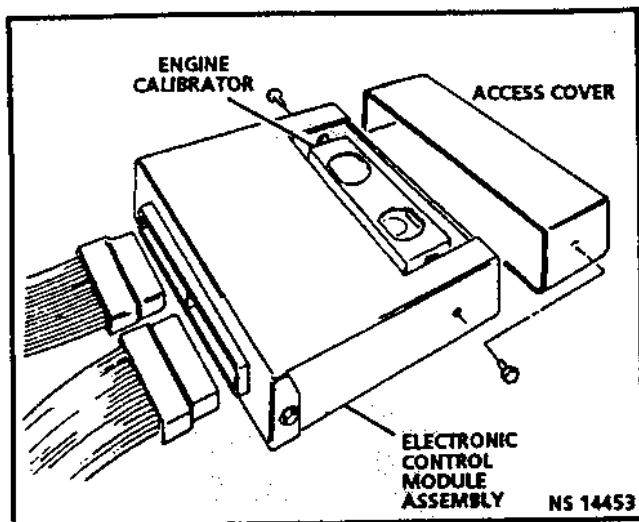

Figure 3.1-3 Electronic Control Module Engine Calibrator Access Cover

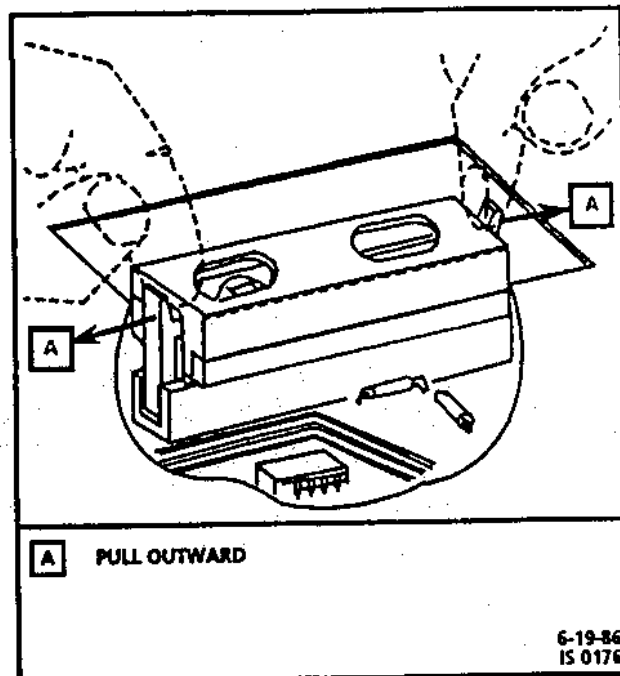

Figure 3.1-4 Engine Calibrator Removal

### ⚠ Important

- Replacement electronic control module is supplied without a memory-calibration unit (engine calibrator) so care should be taken when removing the engine calibrator (See Figure 3.1-4) from the defective electronic control module as it will be reused in the new electronic control module.
- Using two fingers, push both retaining clips back away from the engine calibrator at the same time (See Figure 3.1-4). Grasp the engine calibrator at both ends and lift up out of the engine calibrator socket. Do not remove the cover of the engine calibrator. Use of unapproved engine calibrator removal methods will cause damage to the engine calibrator or engine calibrator socket.

### 🔍 Inspect

- For alignment notches of the engine calibrator and carefully set aside. Do not open the engine calibrator.
- Compare new electronic control module service number to defective electronic control module to ensure correct part replacement.
- The engine calibrator to determine if a cork spacer is glued to the top side of the engine calibrator assembly. If yes, remove it prior to installation.

### ↔ Install or Connect

1. Old engine calibrator in new electronic control module.

### ⚠ Important

- Align the small notches with matching notches in the electronic control module's engine calibrator socket.

VERY GENTLY press down on the ends of the engine calibrator until the locking levers are rotated toward the sides of the engine calibrator. (Figure 3.1-5.)

**NOTICE:** To avoid electronic control module damage, DO NOT press on the ends of the engine calibrator until the levers snap into place. DO NOT use any vertical force beyond the minimum required to engage the engine calibrator into its socket.

While continuing light pressure on the ends of the engine calibrator, use your index fingers to press the locking levers inward until they are snapped into place. Listen for the click.

2. Engine calibrator cover.
3. Electronic control module into vehicle.
4. Connectors.
5. Driver's kick panel.
6. Negative battery cable.

## 3-20 ENGINE MANAGEMENT SYSTEMS 1.7L THROTTLE BODY INJECTION

### ENGINE CALIBRATOR

Code 51 indicates a faulty engine calibrator, bent pins, or incorrect installation.

#### Important

- The engine calibrator is "keyed" to prohibit improper insertion. However, it is essential that the correct engine calibrator be used with a specific model.

**NOTICE:** The ignition should always be "OFF" when installing or removing the electronic control module connectors.

**LOCATION:** Under access cover of electronic control module. (Figure 3.1-3).

#### Remove or Disconnect

- Negative battery cable.
- Driver's kick panel.
- Electronic control module mounting hardware.
- Connectors from electronic control module.
- Electronic control module from passenger compartment.
- Electronic control module access cover.
- Remove engine calibrator assembly. (Figure 3.1-4).

#### Inspect

- The engine calibrator to determine if a cork spacer is glued to the top side of the engine calibrator assembly. If yes, remove it prior to installation.

#### Install or Connect

- Old engine calibrator in new electronic control module.

#### Important

- Align the small notches with matching notches in the electronic control module's engine calibrator socket.

**VERY GENTLY** press down on the ends of the engine calibrator until the locking levers are rotated toward the sides of the engine calibrator. (Figure 3.1-5).

**NOTICE:** To avoid electronic control module damage, **DO NOT** press on the ends of the engine calibrator until the levers snap into place. **DO NOT** use any vertical force beyond the minimum required to engage the engine calibrator into its socket.

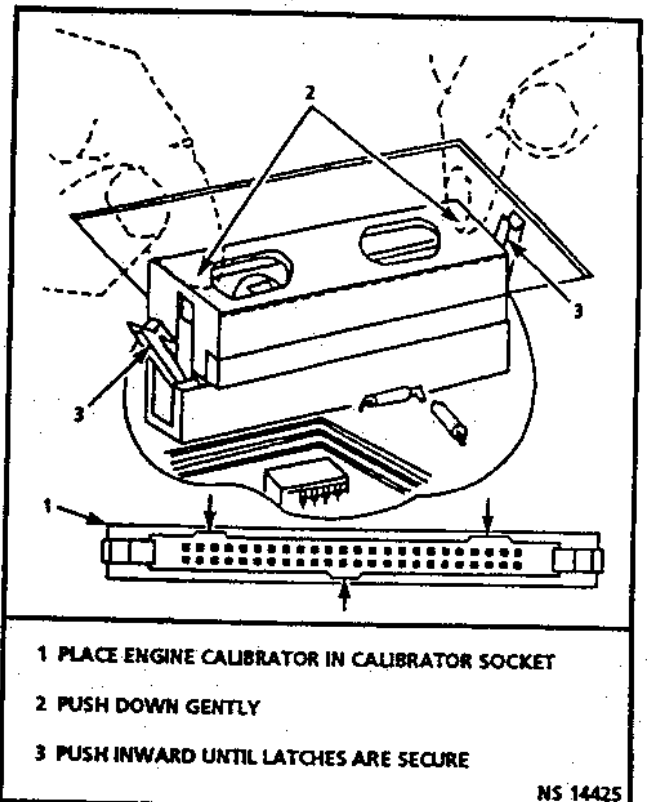

Figure 3.1-5 Engine Calibrator Installation

While continuing light pressure on the ends of the engine calibrator, use your index fingers to press the locking levers inward until they are snapped into place. Listen for the click.

- Engine calibrator cover.
- Electronic control module into vehicle.
- Connectors.
- Driver's kick panel.
- Negative battery cable.

### FUNCTIONAL CHECK

- Turn ignition "ON."
- Enter diagnostics (see diagnostic circuit check for procedure).
  - Code 12 should flash at least four times. (No other codes present). This indicates the engine calibrator is installed properly.
  - If Code 51 occurs or if the "Check Engine" light is "ON" constantly with no codes, the engine calibrator is not fully seated, has bent pins, or is defective.
    - If not fully seated, press firmly on engine calibrator assembly. (Figure 3.1-5).
    - If pins bend, remove engine calibrator, straighten pins, and reinstall.

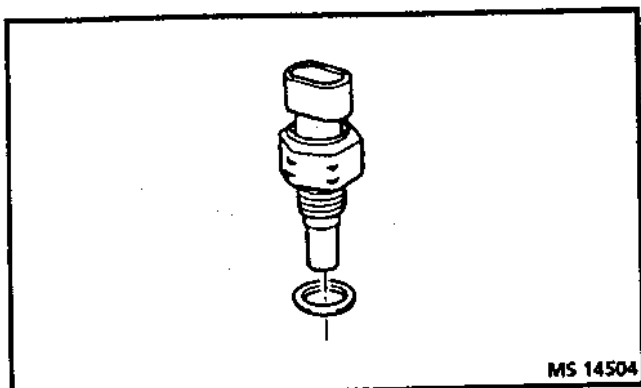

Figure 3.1-6 Coolant Temperature Sensor

**COOLANT TEMPERATURE SENSOR**  
 Figures 3.1-6 and 3.1-7

**⚠ Important**

- Care must be taken when handling coolant sensor. Damage to coolant sensor will affect proper operation of the Fuel Injection system.

**↔ Remove or Disconnect**

1. Ignition "OFF."
2. Electrical connector.
3. Carefully back out coolant temperature sensor.

**↔ Install or Connect**

1. Sensor in engine.
2. Electrical connector.

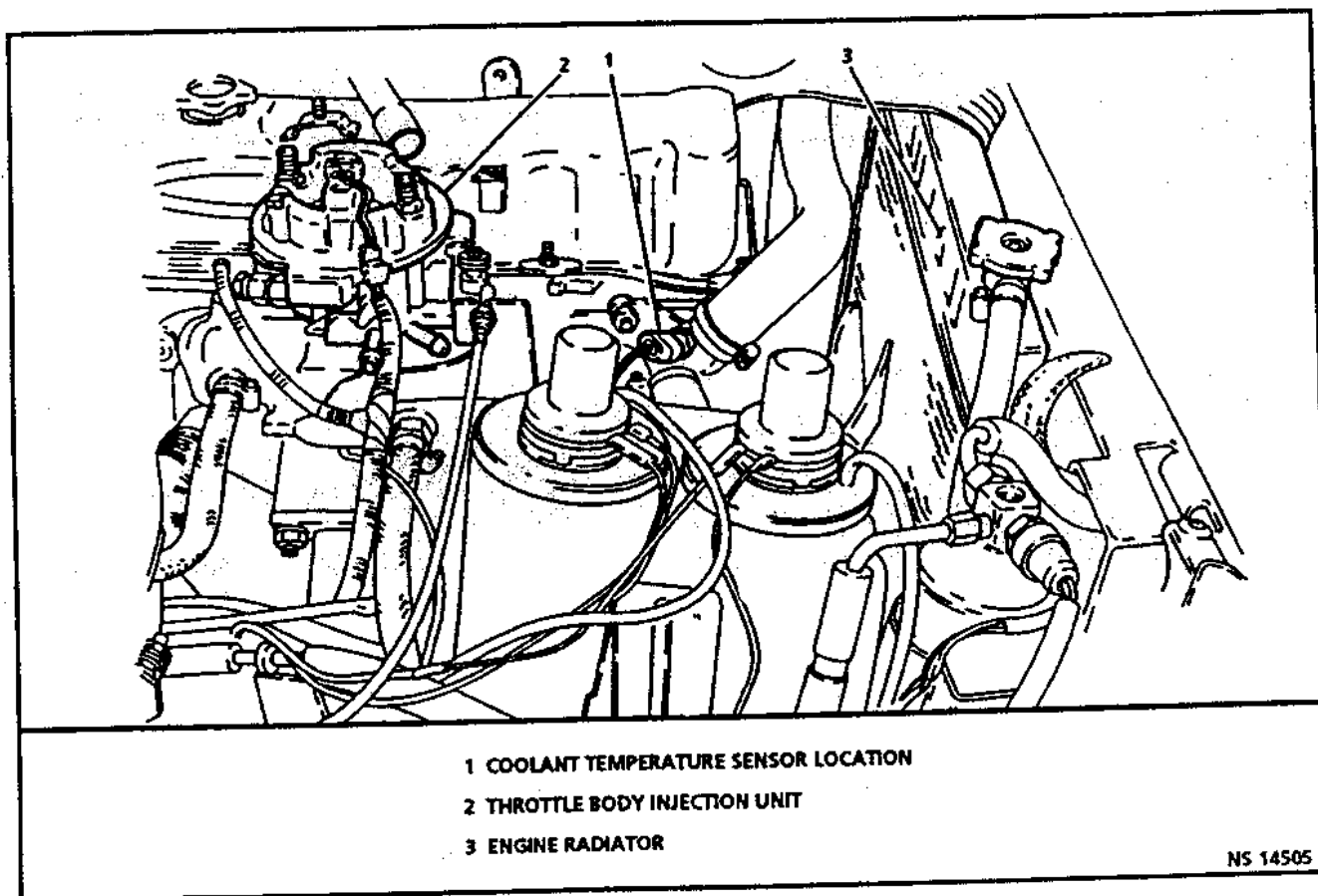

- 1 COOLANT TEMPERATURE SENSOR LOCATION
- 2 THROTTLE BODY INJECTION UNIT
- 3 ENGINE RADIATOR

Figure 3.1-7 Coolant Temperature Sensor Location

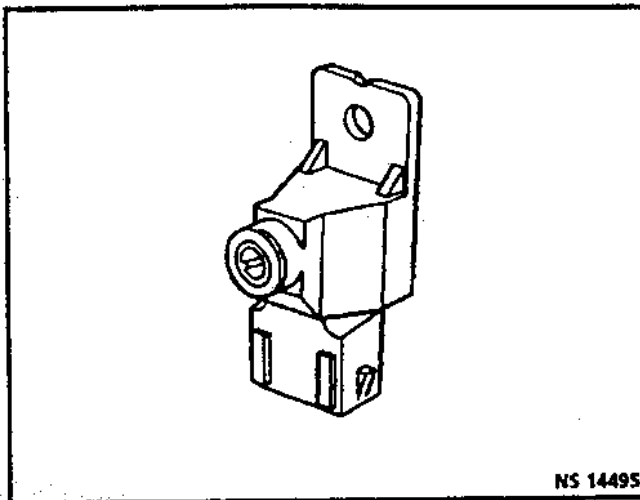

Figure 3.1-8 Octane Adjust Potentiometer

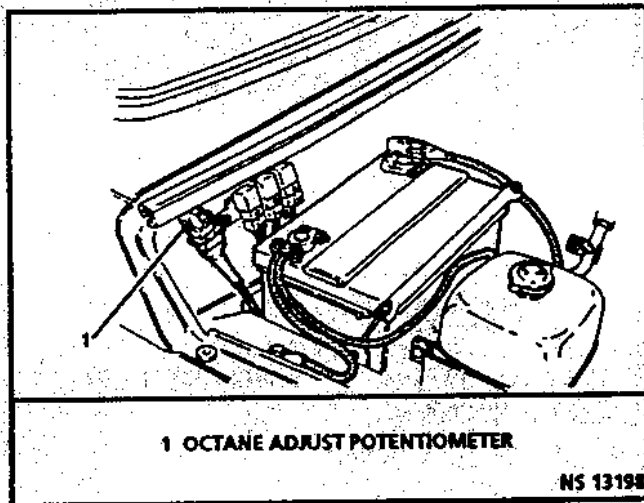

Figure 3.1-9 Octane Adjust Potentiometer Location View

**OCTANE ADJUSTMENT POTENTIOMETER**  
*Figures 3.1-8 and 3.1-9*

**Remove or Disconnect**

1. Electrical connector.
2. Mounting screw(s).
3. Octane adjustment potentiometer.

**Install or Connect**

1. Octane adjustment potentiometer.
2. Mounting screw(s).
3. Electrical connector.
4. The octane adjust potentiometer is preset at the factory at 0° of retard. If an adjustment is needed, refer to CHART C-15.

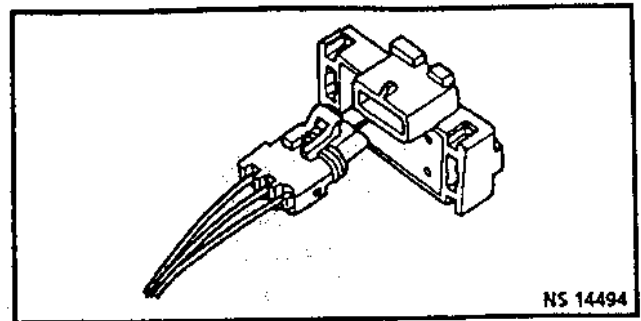

Figure 3.1-10 Manifold Absolute Pressure Sensor

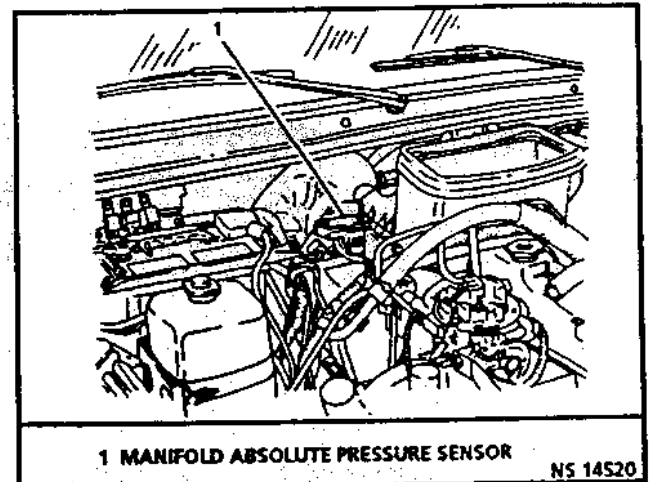

Figure 3.1-11 Manifold Absolute Pressure Sensor Location

**MANIFOLD ABSOLUTE PRESSURE SENSOR**  
*Figure 3.1-10 and 3.1-11*

Other than checking for loose hoses and electrical connections, the only service possible is unit replacement if diagnosis shows sensor to be faulty.

**Remove or Disconnect**

1. Remove air cleaner.
2. Manifold absolute pressure hose.
3. Manifold absolute pressure electrical connector.
4. Mounting screws.
5. Manifold absolute pressure sensor.

**Install or Connect**

1. Manifold absolute pressure sensor.
2. Mounting screws.
3. Manifold absolute pressure electrical connector.
4. Manifold absolute pressure hose.
5. Air cleaner.



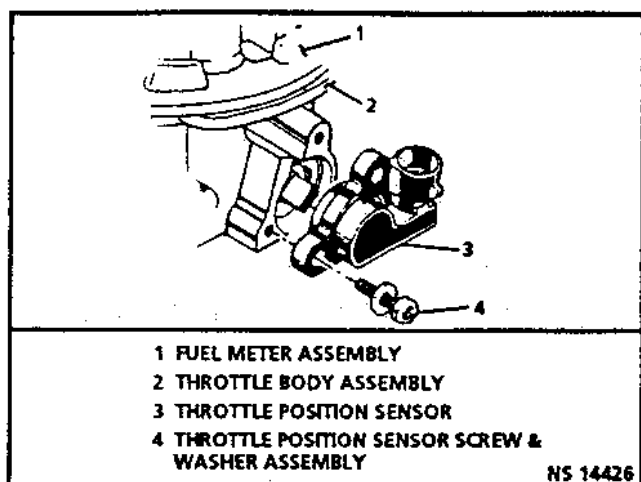

Figure 3.1-12 Throttle Position Sensor

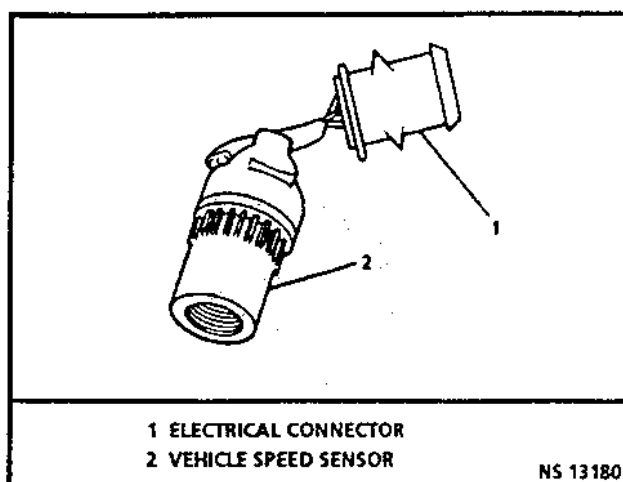

Figure 3.1-14 Vehicle Speed Sensor

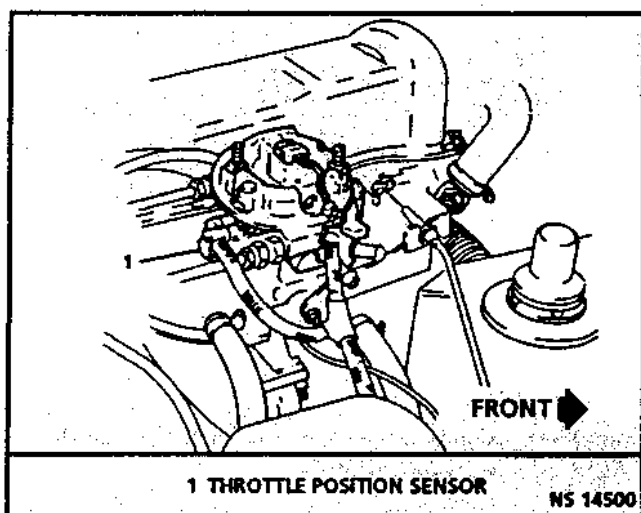

Figure 3.1-13 Throttle Position Sensor Location

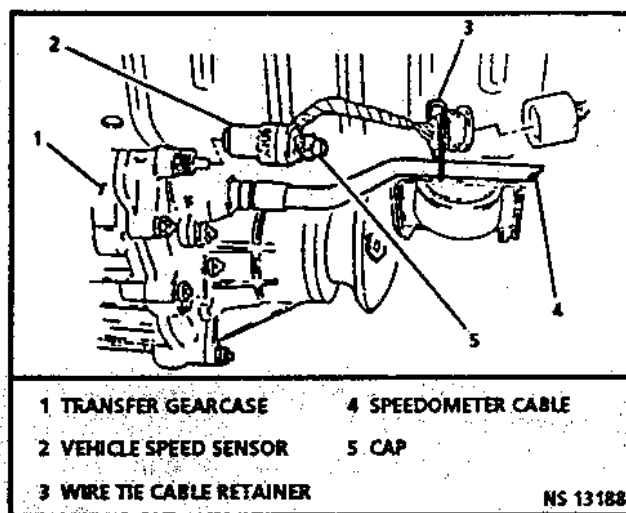

Figure 3.1-15 Vehicle Speed Sensor Location

### THROTTLE POSITION SENSOR

Figure 3.1-12 and 3.1-13

#### Remove or Disconnect

1. Air cleaner.
2. Electrical connector.
3. Two throttle position sensor attaching screws and lock washers.
4. Sensor.

#### Install or Connect

1. Throttle position sensor on throttle body assembly with throttle valve in normal closed position, and throttle position sensor drive tangs aligned with flats on end of the shaft.
2. Throttle position sensor attaching screw and washer assembly on throttle position sensor assembly.
3. Electrical connector.
4. Air cleaner.

#### Tighten

- Attaching screws to 2.0 N·m (18 lb. in.).

### VEHICLE SPEED SENSOR

Figure 3.1-14 and 3.1-15

#### Remove or Disconnect

1. Three wire harness connectors.
2. Wire tie cable retainer that secures the vehicle speed sensor connector to the speedometer cable.
3. Vehicle speed sensor from transmission connection.

#### Install or Connect

1. Vehicle speed sensor to transmission connection.
2. Cable that secures the vehicle speed sensor to the speedometer.
3. Three wire harness connectors.

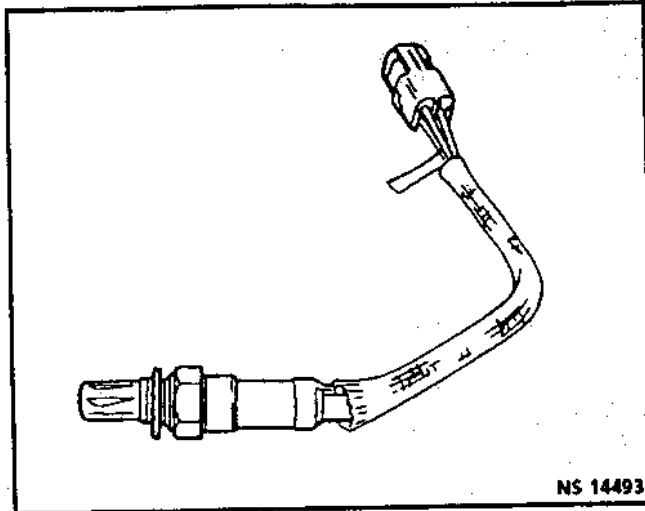

Figure 3.1-16 Oxygen Sensor

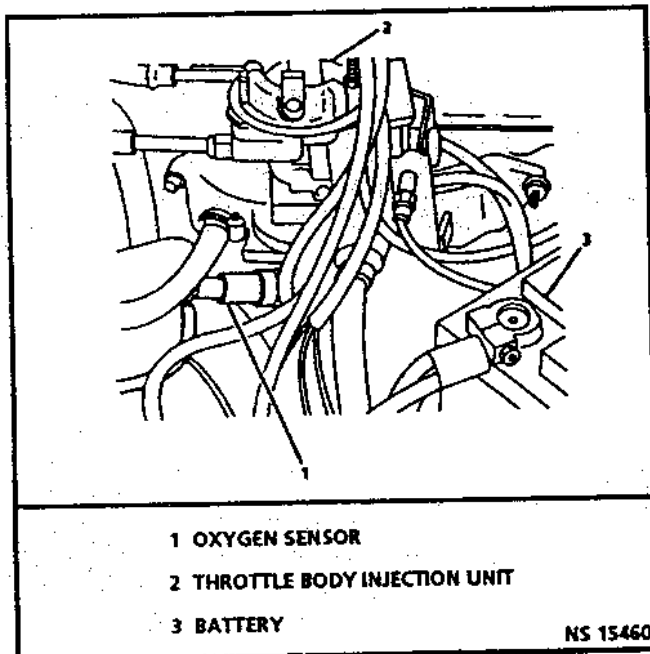

Figure 3.1-17 Oxygen Sensor Location

### OXYGEN SENSOR

Figures 3.1-16 and 3.1-17

#### Remove or Disconnect

1. Negative battery cable.
2. Electrical connector.
3. Carefully back out oxygen sensor.

- The oxygen sensor may be difficult to remove when engine temperature is below 48°C. Excessive force may damage threads in exhaust manifold or exhaust pipe.

#### Important

- Take care when handling the new oxygen sensor. The in-line electrical connector and louvered end must be kept free of grease, dirt or other contaminants. Also, avoid using cleaning solvents of any type. Do not drop or roughly handle the oxygen sensor.

#### Install or Connect

#### Important

- A special anti-seize compound is used on the oxygen sensor threads. The compound consists of a liquid graphite and glass beads. The graphite will burn away, but the glass beads will remain, making the sensor easier to remove.
  - New or service sensors will already have the compound applied to the threads.
1. Sensor and torque to 41 N-m (30 lb. ft.).
  2. Electrical connector.
  3. Negative battery cable.

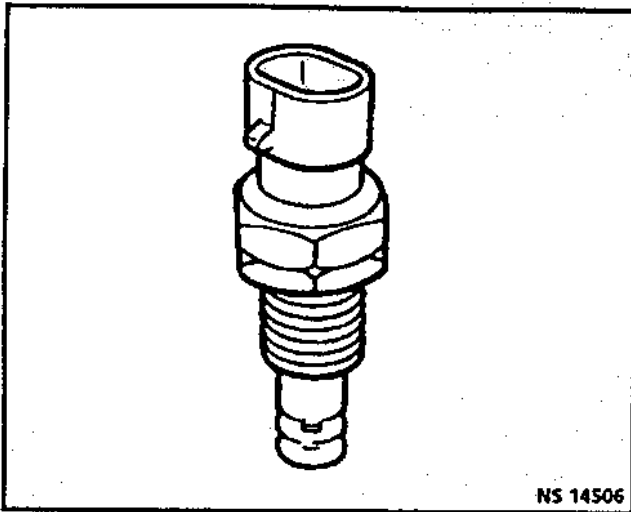

Figure 3.1-18 Intake Air Temperature Sensor

**INTAKE AIR TEMPERATURE SENSOR**  
**Figures 3.1-18 and 3.1-19**

The intake air temperature sensor is located in the air cleaner. The sensor is threaded into the air cleaner as shown in Figure 3.1-19. Be careful not to over tighten the sensor as you install it into the air cleaner.

**Remove or Disconnect**

1. Electrical connector.
2. Sensor.

**Install or Connect**

1. Sensor.
2. Electrical connector.

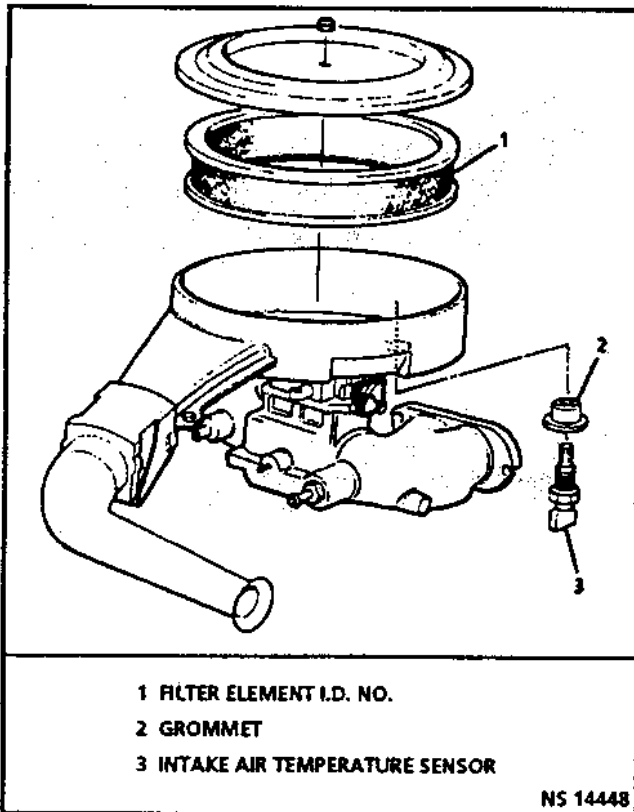

Figure 3.1-19 Intake Air Temperature Sensor Location View

### 3.2 FUEL CONTROL SYSTEM

#### FUEL CONTROL

Always start with the "Diagnostic Circuit Check" in Section "2". This will reduce diagnosis time and prevent unnecessary replacement of parts. The information in this check will direct diagnosis concerning "Engine Cranks But Won't Run" and the Fuel Control System, including diagnosis of the injector, pressure regulator, fuel pump and fuel system relay.

#### Idle Air Control Valve

A Tech 1 "Scan" tool reads idle air control valve position in "Counts" (or steps). "0" steps indicates the electronic control module is commanding the idle air control valve to be driven in, to a fully seated position (minimum idle air). The higher the number of steps, the more idle air is being allowed to pass by the idle air control valve.

Refer to CHART C-2C to diagnose the operation of the idle air control valve.

### ON-VEHICLE SERVICE

#### GENERAL SERVICE INFORMATION

##### CAUTION:

- To prevent personal injury or damage to the vehicle as the result of an accidental start, disconnect and reconnect the negative battery cable before and after service is performed.
- To minimize the risk of fire or personal injury, relieve the fuel system pressure before servicing the throttle body injection unit or any of its fuel handling components. (See "Fuel Pressure Relief Procedure," page 3-28.)
- Also, catch any fuel that leaks out when disconnecting the fuel lines by covering the fittings with a shop cloth. Place the cloth in an approved container when work is complete.

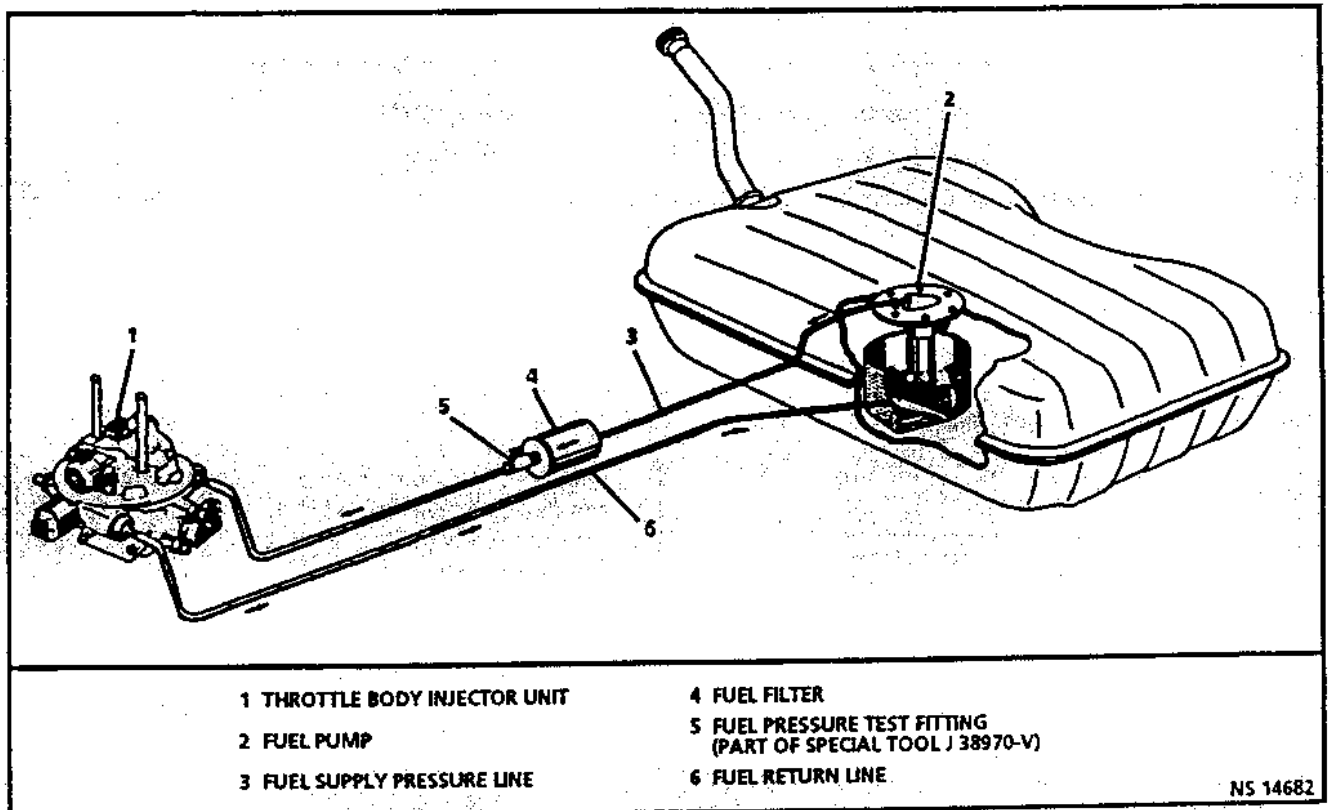

Figure 3.2-1 Fuel System

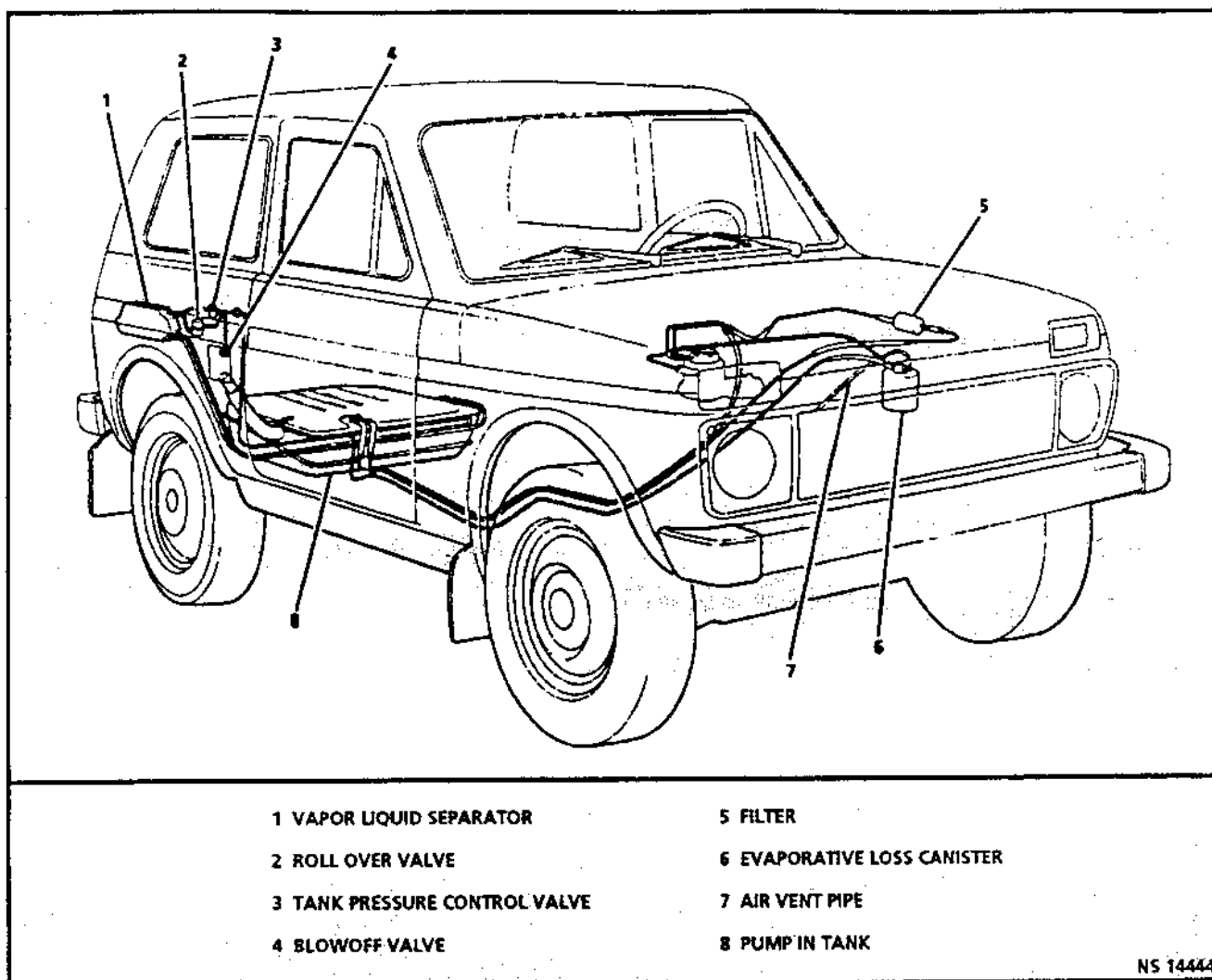

Figure 3.2-2 Additional Fuel System Components in Relation to Location on NIVA

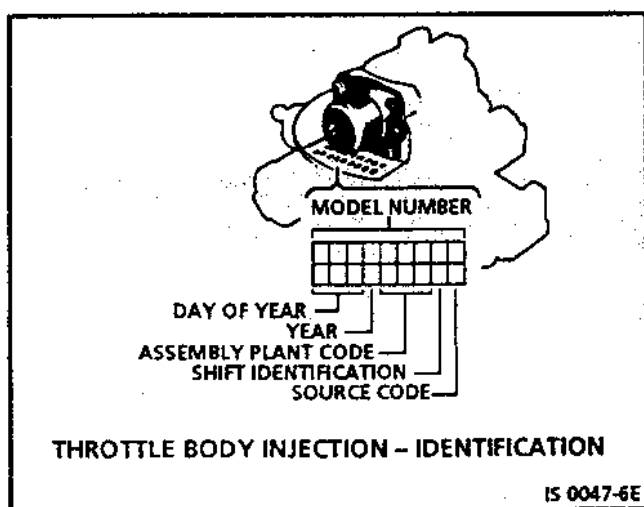

Figure 3.2-3 Throttle Body Injection Identification

The throttle body injection unit repair procedures cover component replacement with the unit on the vehicle. However, throttle body replacement requires that the complete unit be removed from the engine.

Refer to the disassembled view (Figure 3.2-2A, see Page 3-31) for identification of parts during repair procedures. Service repair of individual components is performed without removing the throttle body injection unit from the engine.

**SERVICE IDENTIFICATION**

The Model 700 throttle body injection unit is supplied with the following standard markings:

- Model Number.
- Day, Year, Plant, Shift and Source code.

### 3-28 ENGINE MANAGEMENT SYSTEMS 1.7L THROTTLE BODY INJECTION

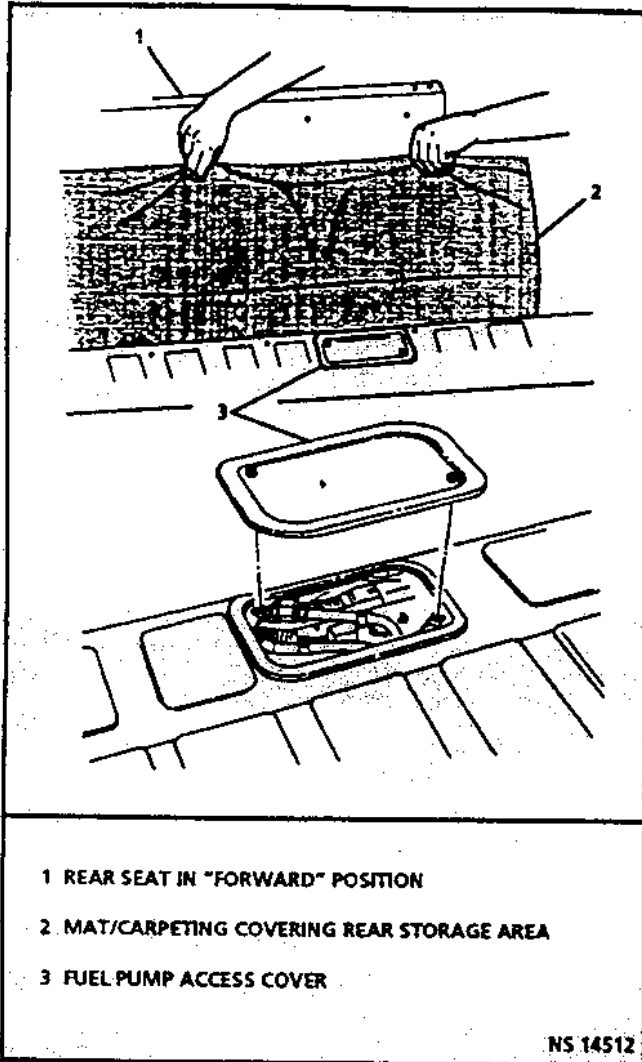

Figure 3.2-4 Fuel Pump Access Panel Location View

The fuel meter assembly is rollmarked with an eight (8) digit model number, date (Julian), year, assembly plant code, shift identification and source code. Figure 3.2-3 shows the rollmark format. Refer to this model number when replacement is required. If the throttle body injection is removed, it is essential that care is taken to prevent damage to the throttle valve or sealing surface while performing any service.

Whenever service is performed on the throttle body injection, first remove the air cleaner and air cleaner gasket. Discard the gasket and replace it with a new one before replacing the air cleaner after service is complete.

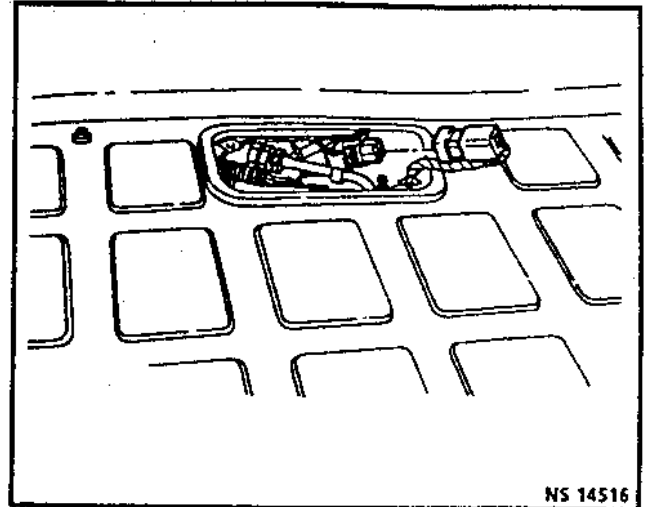

Figure 3.2-5 Fuel Pump Connector

#### FUEL PRESSURE RELIEF PROCEDURE

The throttle body injection Model 700 contains a "checking" fuel feature. This means that fuel pressure is maintained after the engine is shut "OFF." In order to bleed the system, the following procedure *must* be followed.

1. Place transmission selector in neutral, set parking brake, and block drive wheels.
2. Disconnect fuel pump connector at fuel pump (Figures 3.2-4 and 3.2-5).
3. Start engine and allow to idle until it stops running for lack of fuel.
4. Engage starter for three seconds to dissipate fuel pressure in lines. Fuel connections are now safe for servicing.
5. When pressure is relieved and servicing is complete, reconnect fuel pump connector.

#### FUEL SYSTEM PRESSURE TEST

A fuel system pressure test is part of several of the diagnostic charts and symptom checks. To perform this test, follow this procedure:

1. Turn engine "OFF" and relieve fuel pressure, following previous instructions under "Fuel Pressure Relief Procedure."
2. Install fuel pressure gauge onto fuel pressure test fitting making certain the connection is secure to avoid leaking fuel (Figures 3.2-6 and 3.2-7).

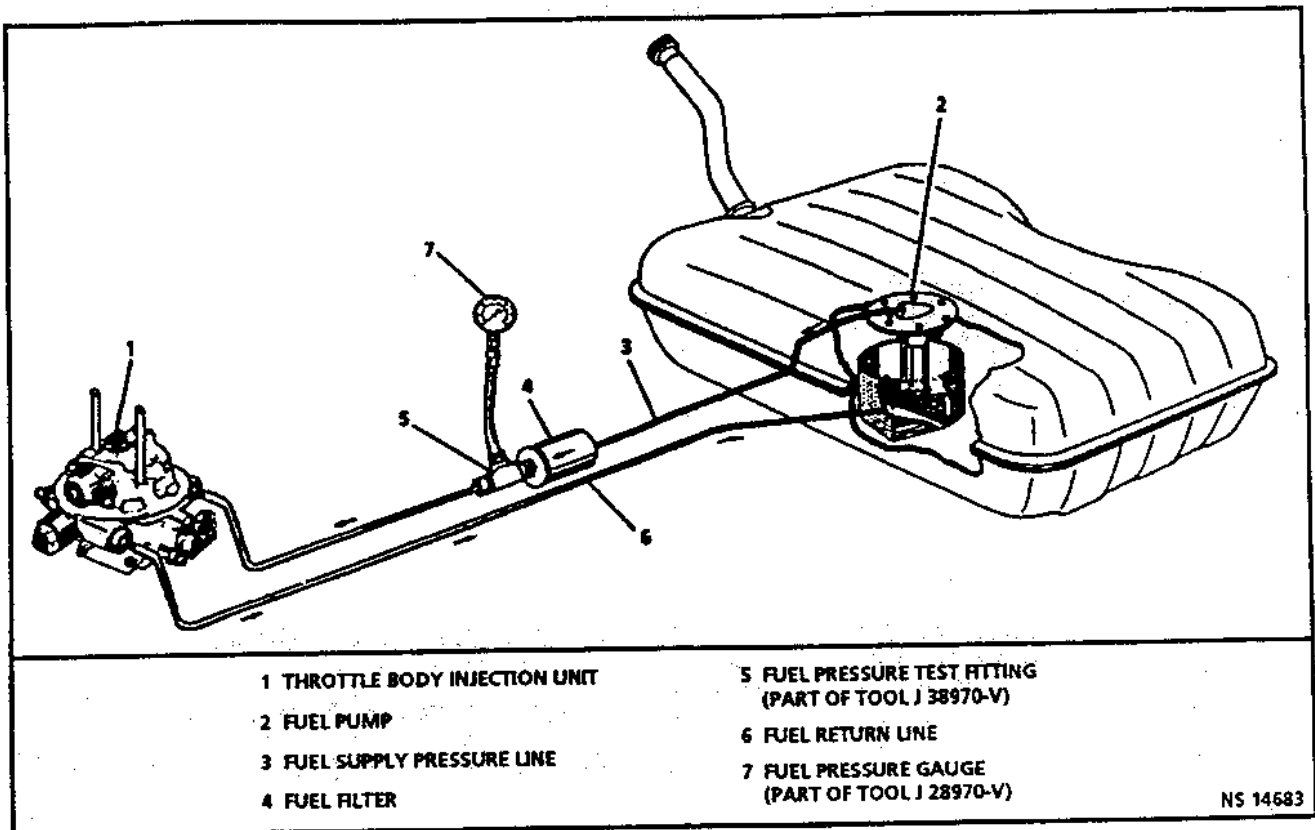

Figure 3.2-6 Fuel Pressure Test

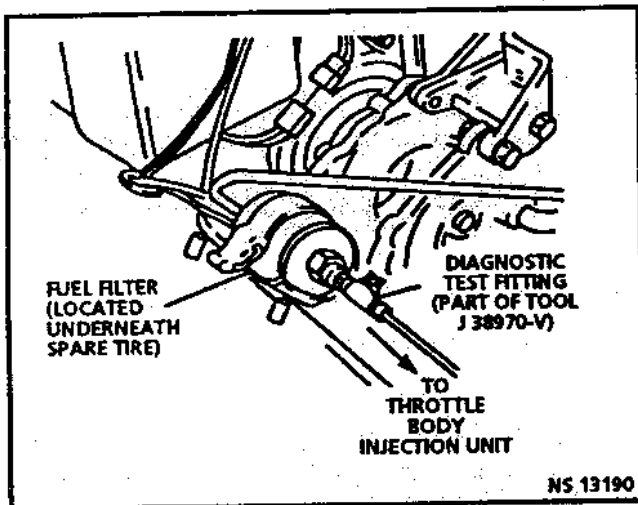

Figure 3.2-7 Fuel Pressure Fitting Location

3. Energize fuel system relay by turning ignition key to the "ON" position. Observe fuel pressure reading, it should be 191.6 to 206.8 kPa (27.8 to 30 psi, 1.9 to 2.1 bar). If not, refer to Chart A-5 or A-7.
4. Relieve fuel pressure. (See "Fuel Pressure Relief.")
5. Remove fuel pressure gauge from fuel pressure test fitting.
6. Start vehicle and check for fuel leaks.
7. Install air cleaner.

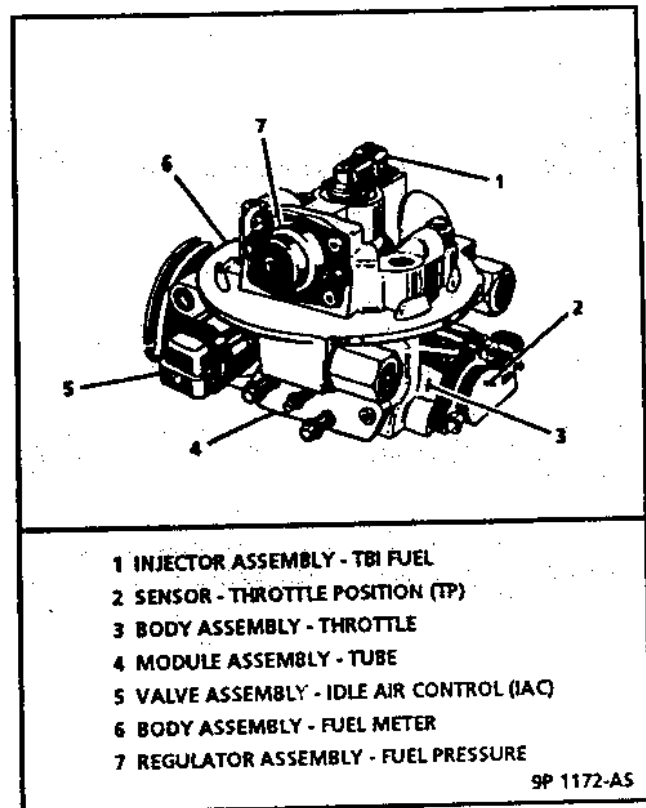

Figure 3.2-8 Throttle Body Injection 700 Components

### 3-30 ENGINE MANAGEMENT SYSTEMS 1.7L THROTTLE BODY INJECTION

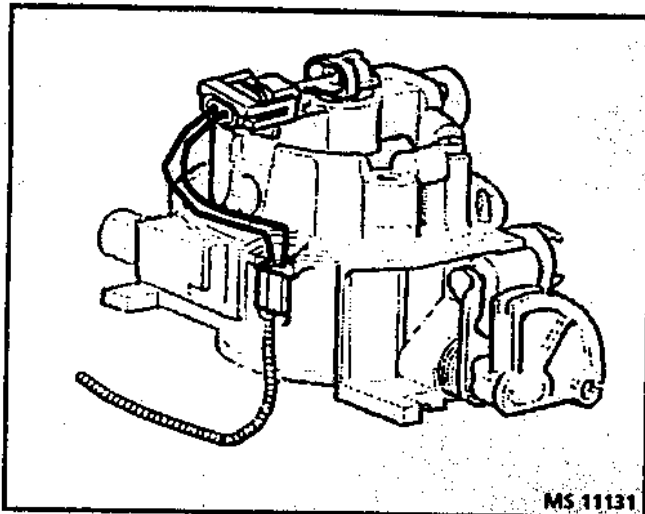
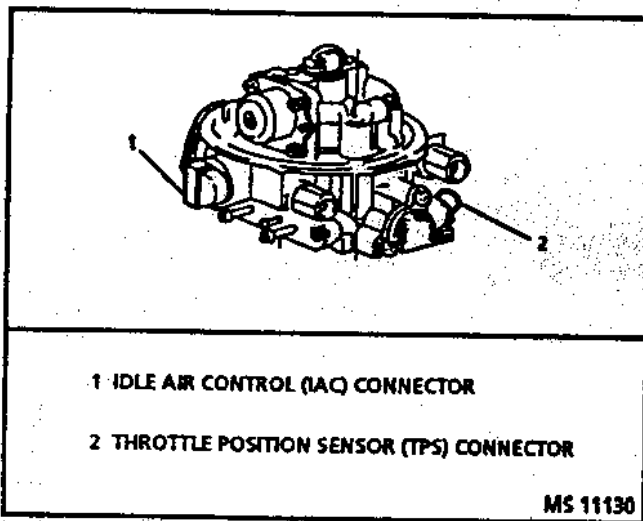

Figure 3.2-9 Throttle Body Injection Injector Electrical Connector



- 1 IDLE AIR CONTROL (IAC) CONNECTOR
- 2 THROTTLE POSITION SENSOR (TPS) CONNECTOR

Figure 3.2-10 Throttle Body Injection Wiring

#### THROTTLE BODY INJECTION UNIT

If the throttle body injection unit is removed, it is essential that care is taken to prevent damage to the throttle valve or sealing surface while performing any service.

When a service throttle body injection unit is installed, first remove the air cleaner and air cleaner gasket. Discard the gasket and replace it with a new one before replacing the air cleaner after service is complete.

#### Remove or Disconnect

1. Electrical connectors for idle air control valve, throttle position sensor, and fuel injector (Figure 3.2-10);

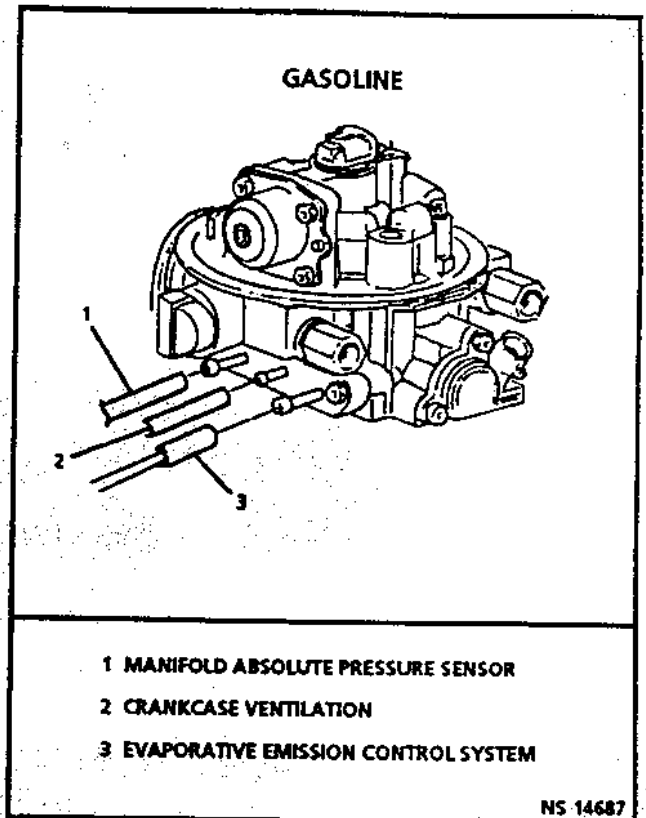

- 1 MANIFOLD ABSOLUTE PRESSURE SENSOR
- 2 CRANKCASE VENTILATION
- 3 EVAPORATIVE EMISSION CONTROL SYSTEM

Figure 3.2-11 Vacuum Hoses

2. Grommet with injector wires from throttle body injection assembly (Figure 3.2-9);
3. Throttle linkage.
4. Vacuum hoses, noting positions of hoses (Figure 3.2-11);
5. Inlet and outlet fuel hose nuts, using back-up wrench (Figure 3.2-12).

**CAUTION:** Refer to fuel pressure relief procedure before servicing fuel systems. See page 3-28.

6. Fuel line O-rings from nuts and discard.
7. Throttle body injection mounting hardware.
8. Throttle body injection unit from intake manifold (Figure 3.2-13).
9. Throttle body injection flange (manifold mounting) gasket and discard.

**NOTICE:** Stuff the manifold opening with a rag to prevent material from entering the engine, and remove the old gasket materials from surface of intake manifold.



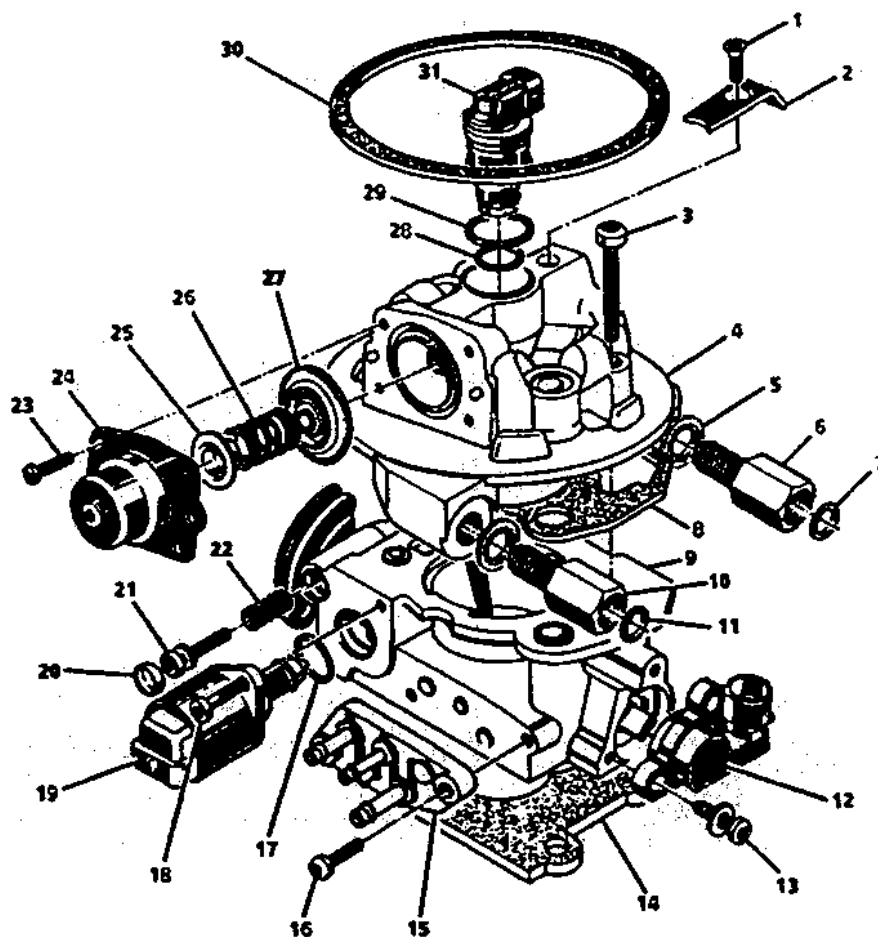

- |   |  |
|---|--|
| 1 SCREW - INJECTOR RETAINER ATTACHING       | 17 O-RING, IAC VALVE                     |
| 2 RETAINER - INJECTOR                       | 18 SCREW - IAC VALVE ATTACHING           |
| 3 SCREW - FUEL METER BODY - THROTTLE BODY   | 19 IDLE AIR CONTROL (IAC) VALVE ASSEMBLY |
| 4 FUEL METER BODY ASSEMBLY                  | 20 PLUG - IDLE STOP SCREW                |
| 5 SEAL - FUEL FITTING                       | 21 IDLE STOP SCREW ASSEMBLY              |
| 6 FITTING - FUEL INLET                      | 22 SPRING - IDLE STOP SCREW              |
| 7 O-RING, FUEL LINE INLET NUT               | 23 SCREW - PRESSURE REGULATOR ATTACHING  |
| 8 GASKET - FUEL METER BODY TO THROTTLE BODY | 24 PRESSURE REGULATOR COVER ASSEMBLY     |
| 9 THROTTLE BODY ASSEMBLY                    | 25 SEAT - PRESSURE REGULATOR SPRING      |
| 10 FITTING - FUEL OUTLET                    | 26 SPRING - PRESSURE REGULATOR           |
| 11 O-RING, FUEL LINE OUTLET NUT             | 27 PRESSURE REGULATOR DIAPHRAGM ASSEMBLY |
| 12 SENSOR, THROTTLE POSITION (TPS)          | 28 O-RING - FUEL INJECTOR - LOWER        |
| 13 SCREW ASSEMBLY - TPS ATTACHING           | 29 O-RING - FUEL INJECTOR - UPPER        |
| 14 GASKET - FLANGE                          | 30 GASKET - AIR CLEANER                  |
| 15 TUBE MODULE ASSEMBLY                     | 31 TBI INJECTOR ASSEMBLY                 |
| 16 SCREW - TUBE MODULE ASSEMBLY             |  |

PS 17728

Figure 3.2-2A Model 700 Throttle Body Injection Parts Identification

### 3-32 ENGINE MANAGEMENT SYSTEMS 1.7L THROTTLE BODY INJECTION

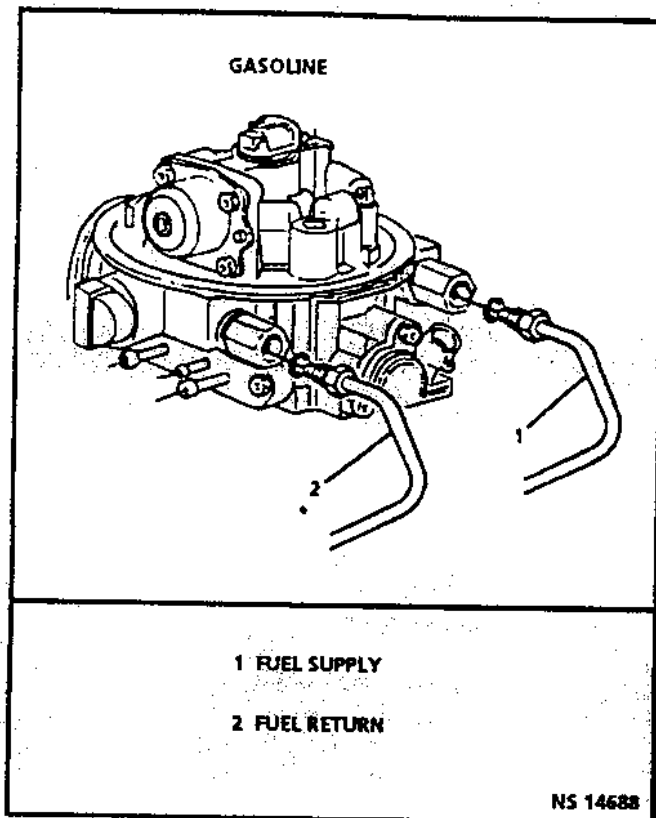

Figure 3.2-12 Fuel Hoses

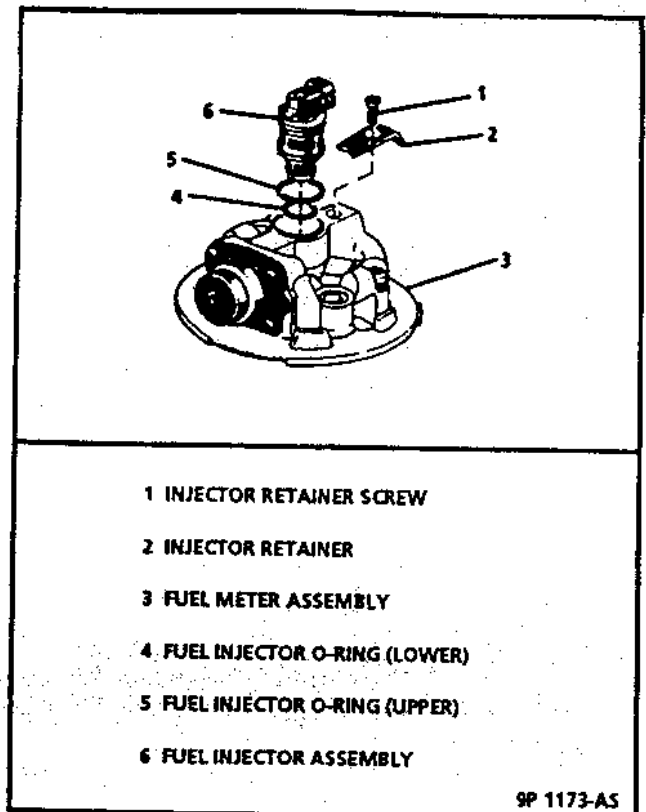

Figure 3.2-14 Fuel Injector Components

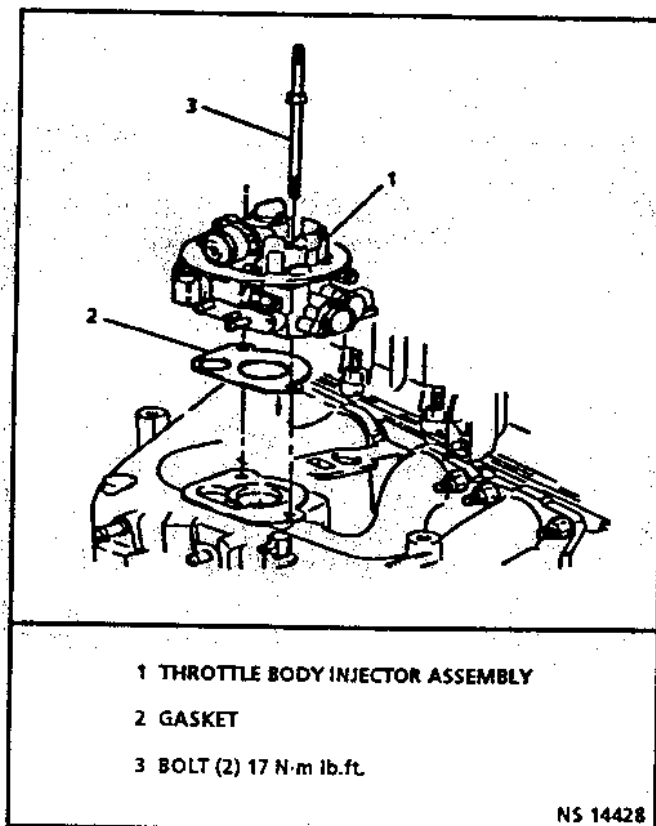

Figure 3.2-13 Removing Throttle Body Injection 700 Unit

#### Clean and Inspect

**NOTICE:** The throttle position sensor, idle air control valve, pressure regulator diaphragm assembly, fuel injector, or other components containing rubber, **SHOULD NOT** be placed in a solvent or cleaner bath. A chemical reaction will cause these parts to swell, harden or distort. Do not soak the throttle body with the above parts attached. If the throttle body requires cleaning, soaking time in the cleaner should be kept to a minimum. Some models have hidden throttle shaft dust seals that could lose their effectiveness by extended soaking.

1. Clean all metal parts thoroughly, and blow dry with shop air. Be sure that all fuel and air passages are free of dirt or burrs.
2. Inspect mating casting surfaces for damage that could affect gasket sealing.
  - Manifold bore for loose parts, foreign material, etc.
  - Intake manifold sealing surfaces for cleanliness.

**Install or Connect**

1. New throttle body injection flange (manifold mounting) gasket
2. Throttle body injection with mounting hardware.

**Tighten**

- Mounting hardware to 17 N·m (12 lb. ft.).
3. New O-rings on fuel line nuts.
  4. Fuel line inlet and outlet nuts by hand.

**Tighten**

- Inlet and outlet nuts to 27 N·m (20 lb. ft.) (Use backup wrench to keep throttle body injection nuts from turning.)

5. Vacuum hoses.
6. Throttle linkage.
7. Grommet with wires to fuel meter assembly.
8. Electrical connectors, making sure connectors are fully seated and latched.
9. Check to see if accelerator pedal is free by depressing pedal to the floor and releasing while engine is "OFF." Check for correct Wide Open Throttle adjustment.
10. Energize the fuel system relay by turning the ignition key to the "ON" position and check for leaks.
11. Start engine and check for fuel leaks.

**FUEL INJECTOR ASSEMBLY**

Figures 3.2-14, 3.2-15, 3.2-16 and 3.2-17

**CAUTION:** Refer to fuel pressure relief procedure before servicing fuel systems. See page 3-28.

**Replacement**

The fuel injector is serviced only as a complete assembly.

**NOTICE:** Use care in removing injector, to prevent damage to the electrical connector on top of the injector, and nozzle. Also, because the fuel injector is an electrical component, it should not be immersed in any type of liquid solvent or cleaner, as damage may occur.

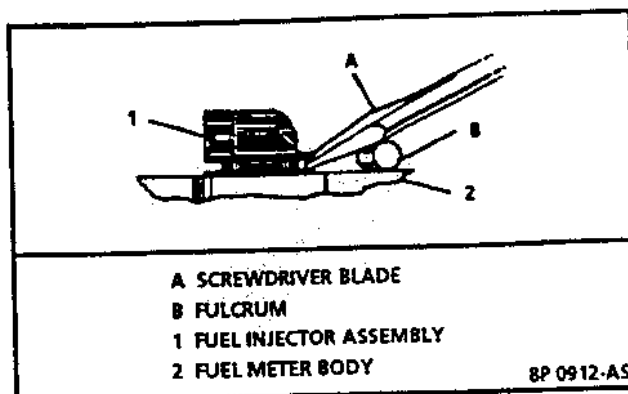

Figure 3.2-15 Removing Throttle Body Injection 700 Fuel Injector

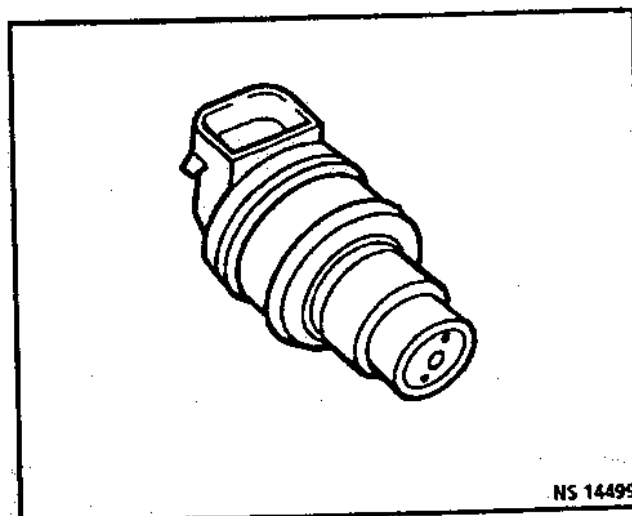

Figure 3.2-16 Fuel Injector

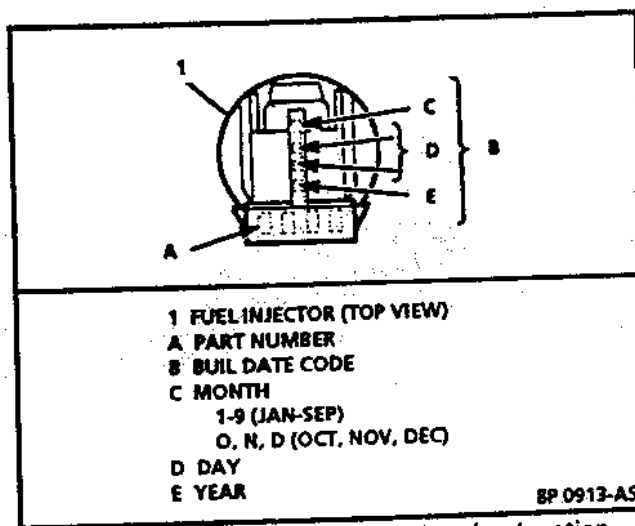

Figure 3.2-17 Fuel Injector Part Number Location

### 3-34 ENGINE MANAGEMENT SYSTEMS 1.7L THROTTLE BODY INJECTION

#### Remove or Disconnect

1. Electrical connector to fuel injector.
2. Injector retainer screw and retainer.
3. Using a fulcrum, place screwdriver blade under ridge opposite connector end and carefully pry injector out (Figure 3.2-15).
4. Remove upper and lower O-rings from injector and in fuel injector cavity and discard.

#### Inspect

- Fuel injector filters for evidence of dirt and contamination. The upper (large diameter) filter is the purge filter, the lower (smaller diameter) filter is the inlet filter. If present, check for presence of dirt in fuel lines and fuel tank.

#### Important

- Be sure to replace the injector with an identical part. Injectors from other models can fit in the Model 700 throttle body injection, but are calibrated for different flow rates. (See Figure 3.2-17 for part number location.)

#### Install or Connect

1. Lubricate new upper and lower O-rings with automatic transmission fluid and place them on injector. (Make sure upper O-ring is in groove and lower one is flush up against inlet filter-smaller.)
2. Injector assembly, pushing it straight into fuel injector cavity.

#### Important

- Be sure the electrical connector end on the injector is facing in the general direction of the cut-out in the fuel meter body for the wire grommet.
3. Injector retainer, using appropriate thread locking compound on retainer attaching screw.
  4. Electrical connector to fuel injector.

#### Tighten

- Injector retainer attaching screw to 3.0 N·m (28.0 lb. in.).
5. Energize the fuel system relay by turning the ignition key to the "ON" position and check for leaks.

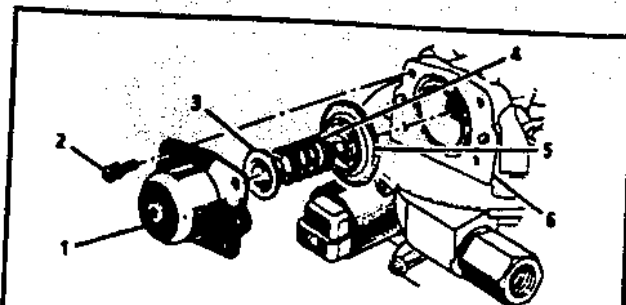

- 1 PRESSURE REGULATOR COVER ASSEMBLY
- 2 COVER SCREW AND WASHER ASSEMBLY
- 3 SPRING SEAT
- 4 SPRING
- 5 DIAPHRAGM ASSEMBLY
- 6 FUEL METER ASSEMBLY

8P 0914-A5

Figure 3.2-18 Throttle Body Injection 700 Pressure Regulator

#### PRESSURE REGULATOR ASSEMBLY

**CAUTION:** Refer to fuel pressure relief procedure before servicing fuel systems. See page 3-28.

#### Replacement Figure 3.2-18

**NOTICE:** To prevent leaks, the pressure regulator diaphragm assembly *must be replaced* whenever the cover is removed.

#### Remove or Disconnect

1. Four pressure regulator attaching screws, while keeping pressure regulator compressed.

**CAUTION:** The pressure regulator contains a large spring under heavy compression. Use care when removing the screws to prevent personal injury.

2. Pressure regulator cover assembly.
3. Pressure regulator spring.
4. Spring seat.
5. Pressure regulator diaphragm assembly.

#### Inspect

- Pressure regulator seat in fuel meter body cavity for pitting, nicks, or irregularities. (Use magnifying glass if necessary). If any of above is present, the whole fuel body casting *must be replaced*.

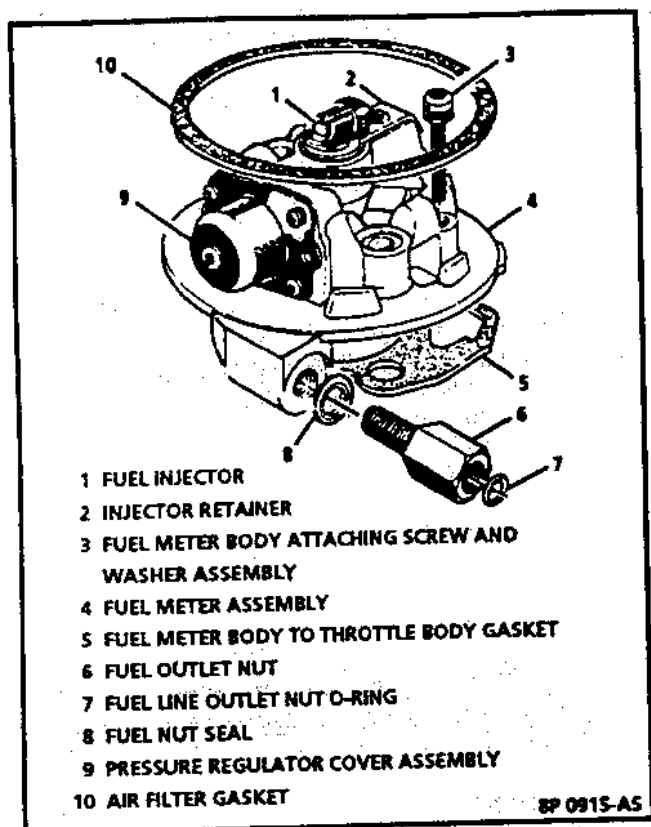

- 1 FUEL INJECTOR
- 2 INJECTOR RETAINER
- 3 FUEL METER BODY ATTACHING SCREW AND WASHER ASSEMBLY
- 4 FUEL METER ASSEMBLY
- 5 FUEL METER BODY TO THROTTLE BODY GASKET
- 6 FUEL OUTLET NUT
- 7 FUEL LINE OUTLET NUT O-RING
- 8 FUEL NUT SEAL
- 9 PRESSURE REGULATOR COVER ASSEMBLY
- 10 AIR FILTER GASKET

8P 0915-A5

Figure 3.2-19 Fuel Meter Assembly

**Install or Connect**

1. New pressure regulator diaphragm assembly, making sure it is seated in groove in fuel meter body.
2. Regulator spring seat and spring into cover assembly.
3. Cover assembly over diaphragm, while aligning mounting holes.

**NOTICE:** Use care while installing the pressure regulator to prevent misalignment of diaphragm and possible leaks.

4. Four screw assemblies that have been coated with appropriate thread locking compound, while maintaining pressure on regulator spring.

**Tighten**

- Attaching screw assemblies to 2.5 N·m (22.0 lb. in.).
5. Energize the fuel system relay by turning the ignition key to the "ON" position and check for leaks.

**FUEL METER ASSEMBLY**

**CAUTION:** Refer to fuel pressure relief procedure before servicing fuel systems. See page 3-28.

**Replacement  
Figure 3.2-19**

**Remove or Disconnect**

1. Electrical connector from fuel injector.
2. Grommet with wires from fuel meter assembly.
3. Inlet and outlet fuel line nuts, using back-up wrench.
4. Fuel line O-rings from nuts and discard.
5. Throttle body injection mounting hardware.
6. Two fuel meter body attaching screw and washer assemblies.
7. Fuel meter assembly from throttle body assembly.
8. Fuel meter body to throttle body gasket and discard.

**Install or Connect**

1. New fuel meter body to throttle body gasket. Match cut-out portions of gasket with openings in throttle body assembly.
2. Fuel meter assembly.
3. Two fuel meter body attaching screw and washer assemblies that have been coated with appropriate locking compound.

**Tighten**

- Attaching screws to 6.0 N·m (53 lb. in.).
4. Throttle body injection unit mounting hardware.

**Tighten**

- Mounting hardware to 17 N·m (12 lb. ft.).
5. New O-rings on fuel line nuts.
  6. Fuel line inlet and outlet nuts by hand.

**Tighten**

- Inlet and outlet nuts to 27 N·m (20 lb. ft.). (Use back-up wrench to keep throttle body injection nuts from turning.)
7. Grommet with wires to fuel meter assembly.
  8. Electrical connector to fuel injector, making sure it is fully seated and latched.
  9. Energize the fuel system relay by turning the ignition key to the "ON" position and check for leaks.

### THROTTLE POSITION SENSOR

#### Replacement

Figure 3.2-20

#### Remove or Disconnect

1. Electrical connector from throttle position sensor.
2. Screw assemblies and throttle position sensor.

**NOTICE:** The throttle position sensor is an electrical component and should not be immersed in any type of liquid solvent or cleaner, as damage may result.

#### Install or Connect

1. With throttle valve in normally closed position, install throttle position sensor on throttle shaft and rotate counterclockwise to align mounting holes.
2. Attaching screw and washer assemblies.

#### Tighten

- Screw assemblies to 2.0 N·m (18.0 lb. in.).
3. Electrical connector to throttle position sensor.
  4. Check for throttle position sensor output as follows:
    - Connect Tech 1 to read throttle position sensor output voltage.
    - With ignition "ON" and engine stopped, throttle position sensor voltage should be less than 1.25 volts. If more than 1.25 volts, replace throttle position sensor.

### IDLE AIR CONTROL VALVE

#### Replacement

Figure 3.2-21

**NOTICE:** The idle air control valve is an electrical component and must not be soaked in any liquid cleaner or solvent. Otherwise, damage could result.

#### Important

- On throttle body injection Model 700, the idle air control valve is flange-mounted, with a dual taper, 10 mm diameter pintle. If replacement is necessary, only an idle air control valve identified with the correct part number (having the appropriate pintle shape and diameter) should be used.

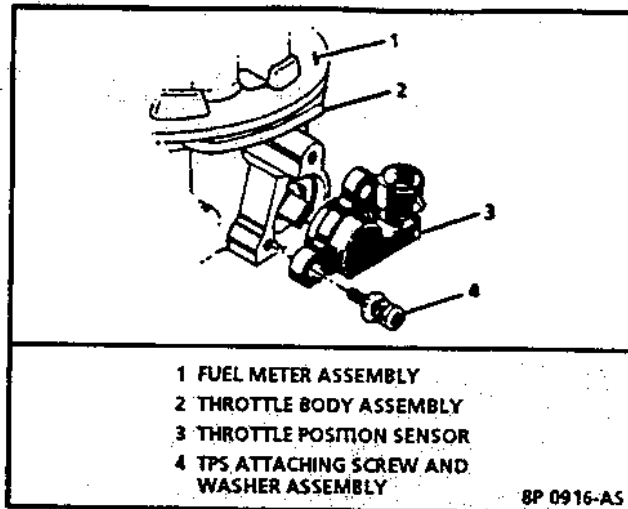

Figure 3.2-20 Throttle Position Sensor

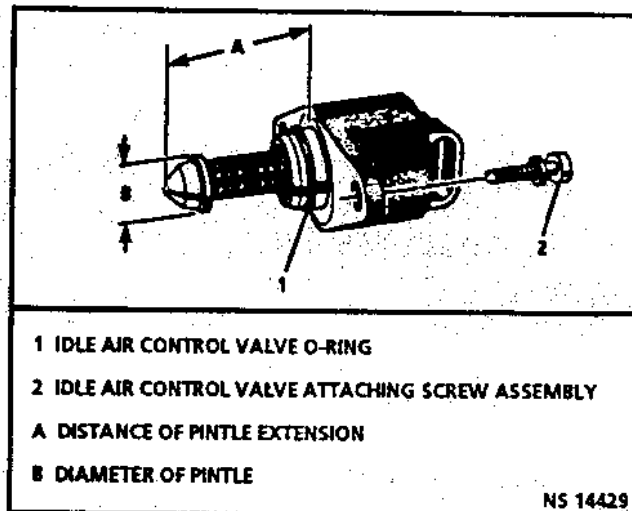

Figure 3.2-21 Flange-Mount Idle Air Control Valve

#### Remove or Disconnect

1. Electrical connector from idle air control valve.
2. Screw assemblies and idle air control valve.
3. Idle air control valve O-ring and discard. New O-ring is included in service replacement kit.

**NOTICE:** Before inserting the idle air control valve assembly, measure the distance from the idle air control valve mounting flange to the point of the idle air control valve pintle. If the pintle is extended too far, damage to the idle air control valve assembly may result. (Figure 3.2-21).

**Measure**

- Distance from idle air control valve mounting flange to the point of pintle. Distance *must* be less than 28 mm.

**Adjust, if necessary**

- If distance is greater than 28 mm, apply firm hand pressure to retract it. (A slight side-to-side motion may be helpful.)

**Install or Connect**

- New O-ring on idle air control valve.
- Idle air control assembly in throttle body assembly with attaching screws.
- Electrical connector to idle air control valve.

**Important**

- No adjustment of the idle air control valve is made after installation. With the Tech 1 connected and engine running, select "Miscellaneous Tests," then "Idle System," then "Idle Reset." This will command the electronic control module to reset the idle air control valve.

**TUBE MODULE ASSEMBLY**

**Replacement**  
*Figure 3.2-22*

**Remove or Disconnect**

- Tube module assembly attaching screws.
- Tube module assembly.
- Tube module assembly gasket (O-ring) and discard.

**Clean**

- Old gasket (O-ring) material from surface of throttle body assembly to ensure proper seal of new gasket (O-ring).

**Install or Connect**

- New tube module assembly gasket (O-ring).
- Tube module assembly.
- Tube module assembly attaching screws.

**Tighten**

- Screw assemblies to 3.0 N·m (28.0 lb.in.).

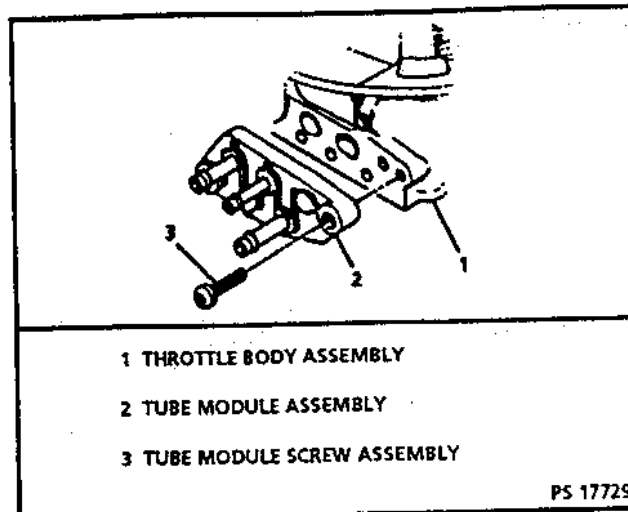

**Figure 3.2-22 Tube Module Assembly**

**THROTTLE BODY ASSEMBLY**

**CAUTION:** Refer to fuel pressure relief procedure before servicing fuel systems. See page 3-28.

**Replacement**  
*Figure 3.2-23*

**NOTICE:** Procedures related to replacement of the individual components below have been described previously and should be followed or damage could occur.

**Remove or Disconnect**

- Throttle body injection unit, as described above.
- Fuel meter body-to-throttle body attaching screw and washer assemblies.
- Fuel meter assembly.
- Fuel meter body to throttle body gasket and discard.

**Disassemble**

- Throttle position sensor, idle air control valve and tube module assembly from old throttle body assembly, according to previous instructions.

**Assemble**

- Throttle position sensor, idle air control valve, and tube module assembly onto replacement throttle body assembly, according to previous instructions.

**Install or Connect**

- New fuel meter body to throttle body gasket.
- Fuel meter assembly on throttle body assembly.
- Fuel meter body-to-throttle body attaching screw and washer assemblies.

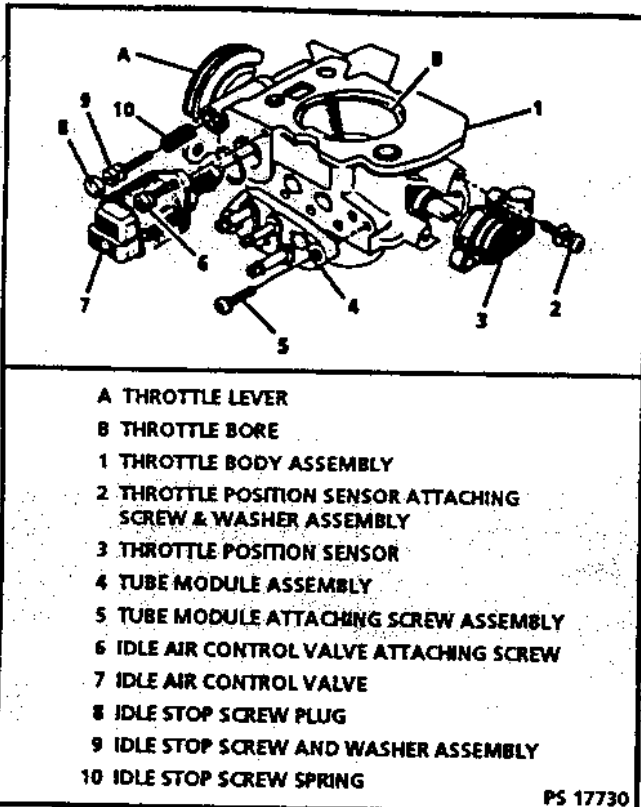

Figure 3.2-23 Throttle Body Assembly - Typical

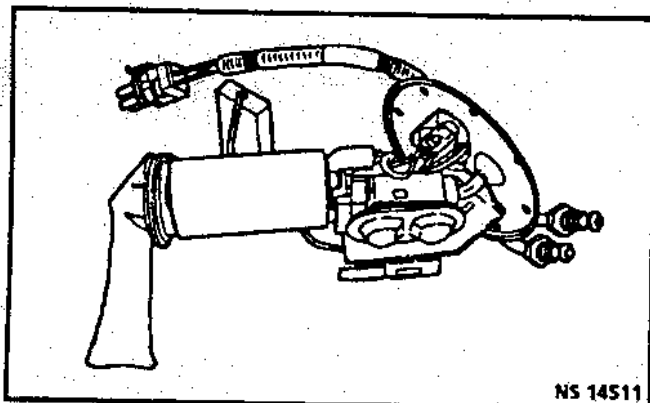

Figure 3.2-24 Fuel Pump

**Tighten**

- Screws to 6.0 N·m (53 lb. in.).

4. Throttle body injection unit onto engine, as described in "Throttle Body Injection Unit."

**FUEL PUMP**

**CAUTION:** Refer to fuel pressure relief procedure before servicing fuel systems. See page 3-28.

**Replacement**

The fuel pump (see Figure 3.2-24) is a roller vane type, electric pump, mounted inside of the fuel tank.

Fuel is pumped at a positive pressure above 190.2 kPa (27.6 psi, 1.9 bar) from the fuel pump through the in-line filter to the pressure regulator in the throttle body injection assembly. Excess fuel is returned to the fuel tank through the fuel return line.

Vapor lock problems are reduced when using an electric pump because the fuel is pushed under pressure rather than pulled under vacuum, a condition that produces vapor.

**Remove or Disconnect**

1. Fold rear seat forward and lift up mat covering storage area.
2. Fuel pump access cover.
3. Fuel pump electrical connector (Figure 3.2-4 and 3.2-25).
4. Fuel lines.
5. Fuel tank from vehicle after removing hold down straps and bolts.
6. Fuel pump retaining bolts and carefully remove pump from tank.

**Install or Connect**

1. New fuel pump into fuel tank.
2. Fuel pump retaining bolts. Tighten securely.
3. Fuel tank under vehicle and secure using hold down straps and bolts.
4. Fuel lines.

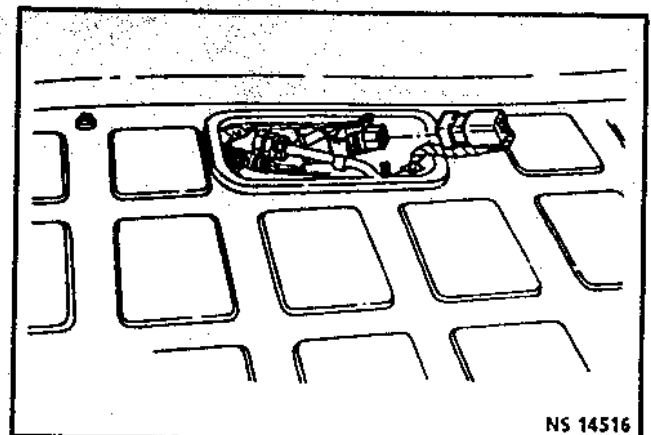

Figure 3.2-25 Fuel Pump Connector



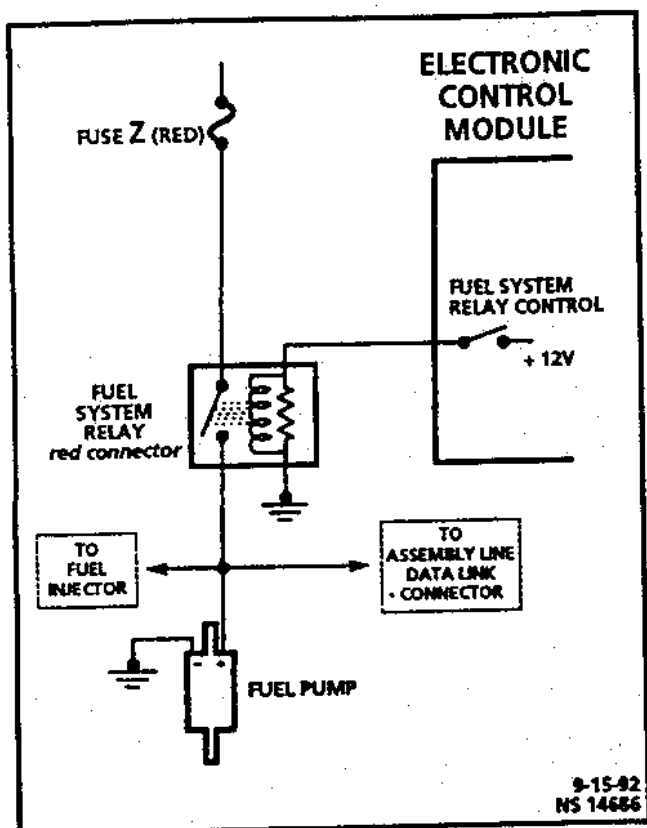

Figure 3.2-26 Fuel Pump Electrical Circuit

5. Fuel pump electrical connector.
6. Fuel pump access cover.
7. Return rear seat to normal position.

Energize the fuel system relay by turning the ignition key to the "ON" position and check for leaks.

### FUEL PUMP ELECTRICAL CIRCUIT Figure 3.2-26

When the ignition is first turned "ON" without the engine running, the electronic control module will turn the fuel pump relay "ON" for two seconds. This builds up the fuel pressure quickly. If the engine is not cranked within two seconds, the electronic control module will shut the fuel pump "OFF" and wait for the reference signal. As soon as the engine is cranked, the electronic control module will turn the relay "ON" and run the fuel pump.

### FUEL SYSTEM RELAY Figure 3.2-27

The fuel system relay is mounted in the fuse panel. Other than checking for loose connectors, the only service possible is replacement (see Figure 3.2-27).

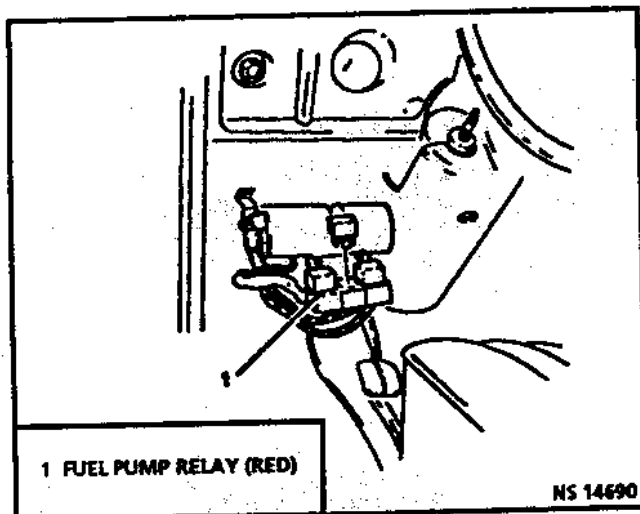

Figure 3.2-27 Fuel System Relay

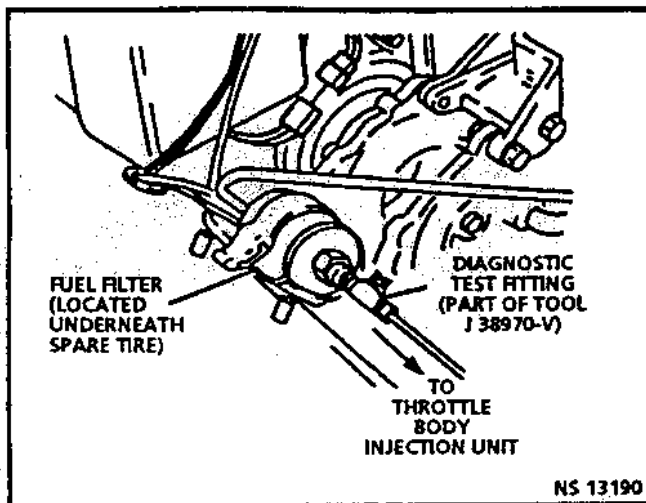

Figure 3.2-28 Fuel Filter

#### FUEL FILTER

**CAUTION:** Refer to fuel pressure relief procedure before servicing fuel systems. See page 3-28.

#### Replacement Figure 3.2-28

##### Important

- Before proceeding, refer to the "Fuel Pressure Relief" procedure found earlier in this section.

##### Remove or Disconnect

1. Fuel line to fuel filter attachment nuts. (Be careful not to lose the O-rings that are installed between the fuel filter and fuel lines.)
2. Fuel filter hold down strap.

##### Important

- Inspect O-rings for cuts, nicks or abrasions. Replace if necessary.

##### Install or Connect

1. Fuel filter hold-down strap.
2. Fuel line to fuel filter attachment nuts, including the rubber O-rings.

Energize the fuel system relay by turning the ignition key to the "ON" position and check for leaks.

### 3.3 EVAPORATIVE EMISSION CONTROL SYSTEM

#### ON-VEHICLE SERVICE

#### VISUAL CHECK OF CANISTER

- Cracked or damaged, replace canister.
- Fuel leaking from bottom of canister vent hose, replace canister and check hoses and hose routing.

#### FUEL VAPOR CANISTER

##### Remove or Disconnect

1. Electrical connector.
2. Hoses from fuel vapor canister.
3. Attaching screws (2).
4. Fuel vapor canister.
5. Retaining clips.

##### Install or Connect

1. Retaining clips.
2. Fuel vapor canister as removed.
3. Attaching screws (2).

##### Tighten

- Fuel vapor canister attaching screws 3 N·m (27 lb. in.).
4. Hoses.
  5. Electrical connector.

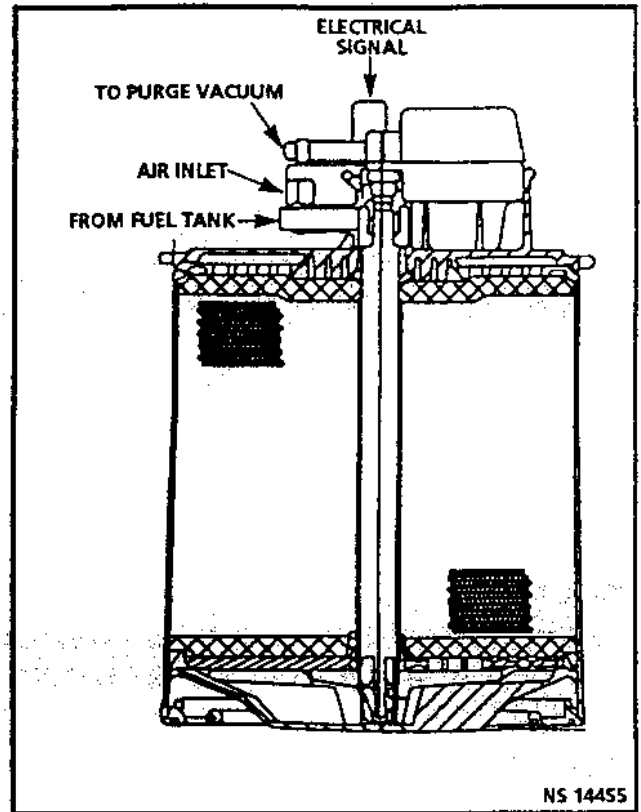

Figure 3.3-1 Vapor Canister

#### FUEL VAPOR CANISTER HOSES

Refer to "Vehicle Emission Control Information" label for routing of fuel vapor canister hoses.

### 3-42 ENGINE MANAGEMENT SYSTEMS 1.7L THROTTLE BODY INJECTION

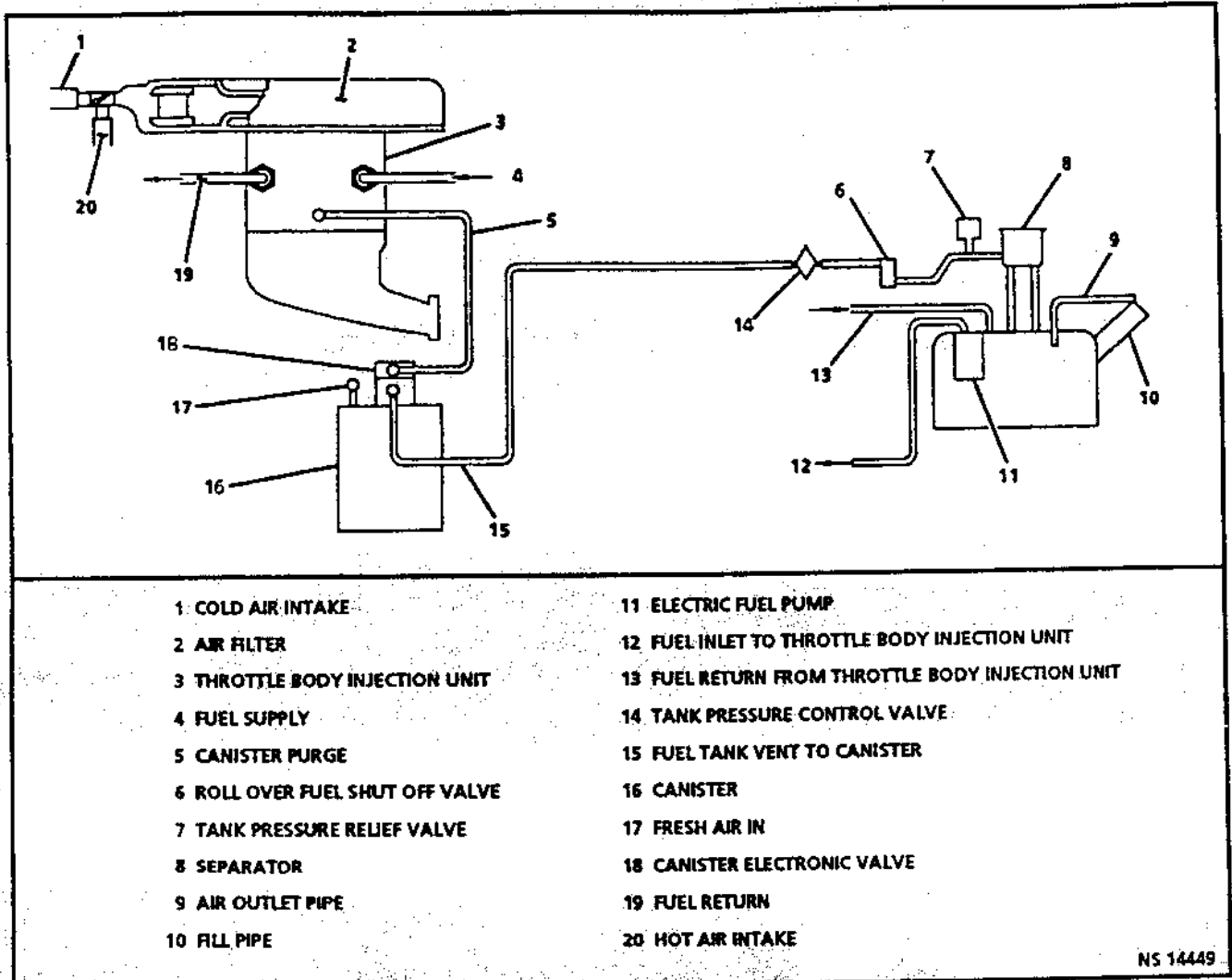

Figure 3.3-2 Evaporative Emission Control System

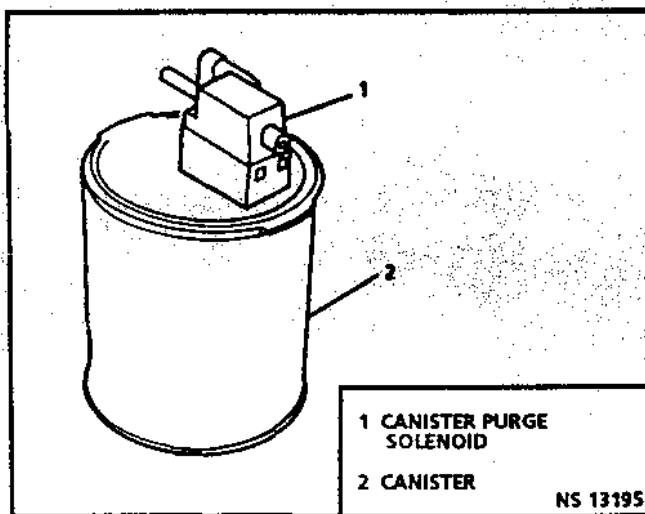

Figure 3.3-3 Canister Purge Solenoid - Removal

### 3.4 DIRECT IGNITION SYSTEM

#### ON-VEHICLE SERVICE

#### DIRECT IGNITION SYSTEM ASSEMBLY

Figures 3.4-1 and 3.4-2

##### Remove or Disconnect

1. Negative battery cable.
2. Direct ignition system electrical connectors, including harness ground terminals from bracket.
3. Spark plug wires. (Note proper relationship of wires to coils.)
4. Direct ignition system assembly to engine bolts (3).
5. Direct ignition system assembly from engine.

##### Install or Connect

1. Direct ignition system assembly to engine.
2. Direct ignition system assembly to block bolts(3).

##### Tighten

- Torque to 20-30 N·m (15-22 lb. ft.).
3. Spark plug wires to proper coils.

4. Direct ignition system electrical connectors harness ground terminals.
5. Negative battery cable.

#### IGNITION COIL

##### Remove or Disconnect

1. Coil retaining screws (2 per coil).
2. Coil from module.

##### Install or Connect

1. Coil to module.
2. Coil retaining screws.

##### Tighten

- Torque to 4.5 N·m (40 lb. in.).

#### IGNITION MODULE

##### Remove or Disconnect

1. Negative battery cable.
2. Direct ignition system assembly from engine. (See previous procedure.)
3. Coils from assembly. (See previous procedure.)
4. Module from assembly plate.

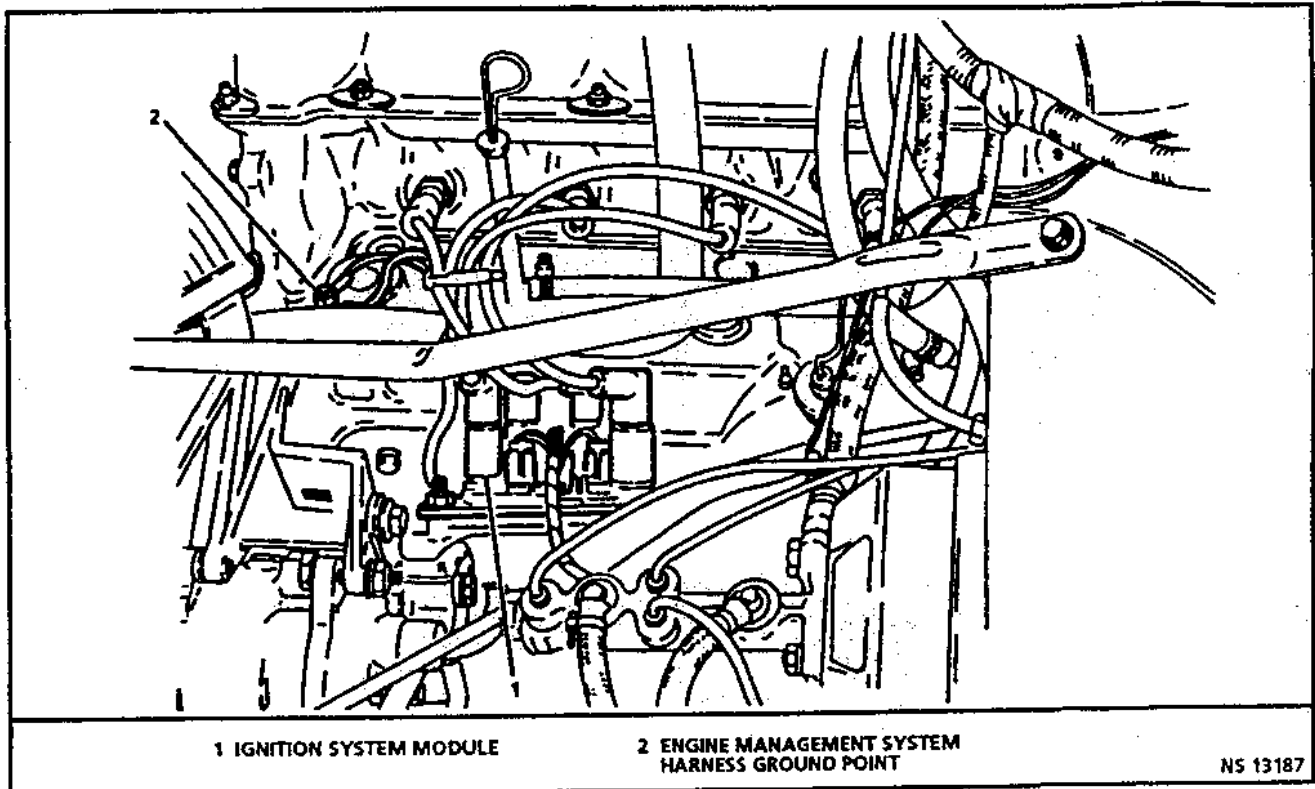

Figure 3.4-1 Ignition Components

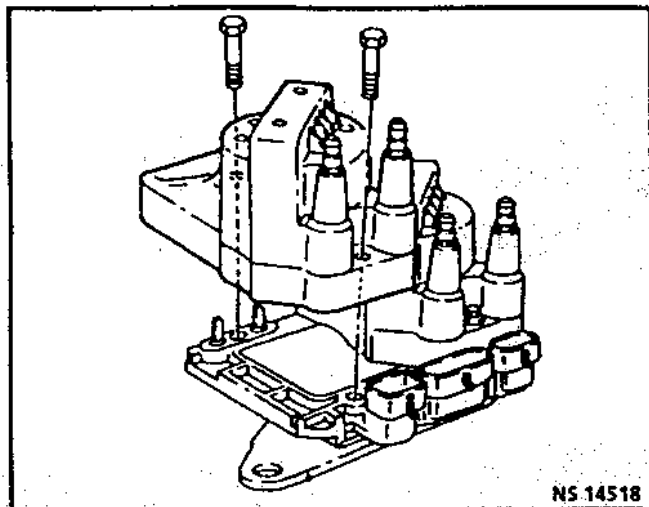

Figure 3.4-2 Direct Ignition System Coil Removal

**Install or Connect**

1. Module to assembly plate.
2. Coils. (See previous procedure.)
3. Direct ignition system assembly to engine. (See previous procedure.)
4. Negative battery cable.

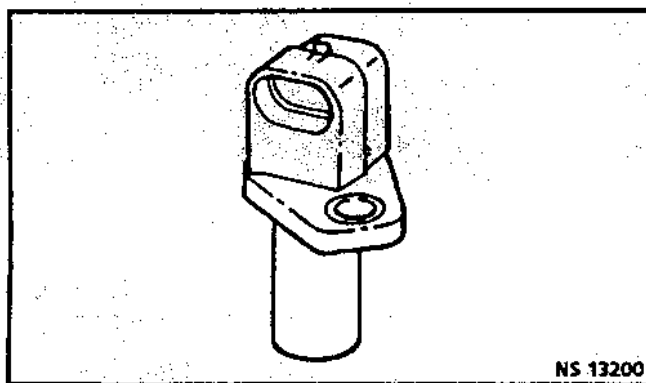

Figure 3.4-3 Crankshaft Sensor

**CRANKSHAFT SENSOR**  
*Figures 3.4-3 and 3.4-4*

**Remove or Disconnect**

1. Sensor harness connector at module.
2. Sensor to block bolt (1).
3. Sensor from engine.

**Inspect**

- Sensor O-ring for wear, cracks or leakage. Replace if necessary. Lube new O-ring with engine oil before installing.

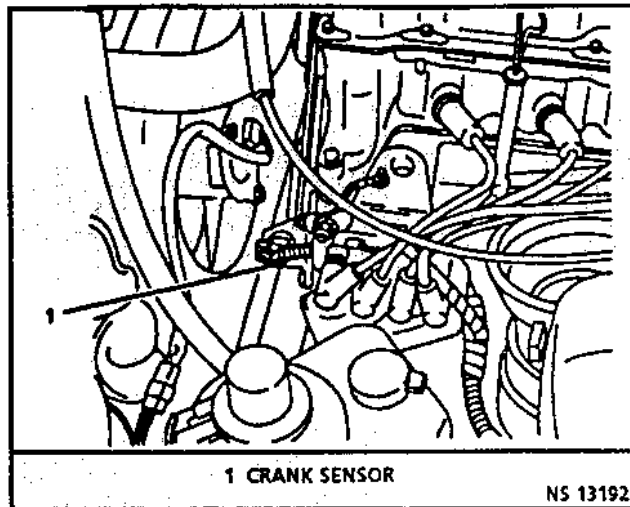

Figure 3.4-4 Crankshaft Sensor Location View

**Install or Connect**

1. Sensor into hold in block.
2. Sensor to block bolt (1).

**Tighten**

- Torque to 6-12 N·m (53-107 lb. in.).

3. Sensor harness connector at module.

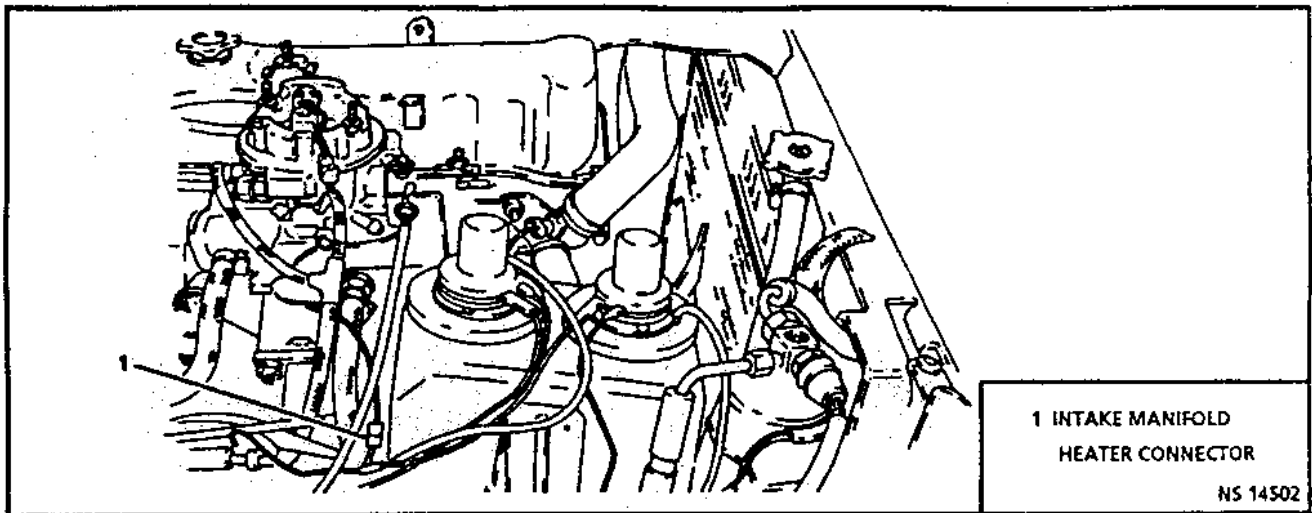

Figure 3.9-1 Intake Manifold Heater Connector

### 3.9 INTAKE MANIFOLD HEATER ON-VEHICLE SERVICE

#### INTAKE MANIFOLD HEATER ASSEMBLY *Figures 3.9-1 and 3.9-2*

##### Remove or Disconnect

1. Negative battery cable.
2. Intake manifold heater connector (Figure 3.9-1).
3. (3) manifold heater to intake manifold connecting bolts.
4. Intake manifold heater and gasket from underside of intake manifold (Figure 3.9-2).

##### Important

- Inspect gasket for cracks or tears. Replace if necessary.

##### Install or Connect

1. Intake manifold heater and gasket to intake manifold.
2. (3) manifold heater to intake manifold connecting bolts.
3. Intake manifold heater connector.
4. Negative battery cable.

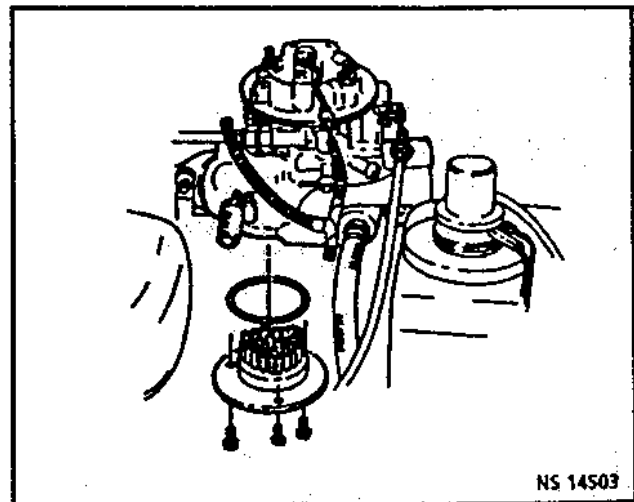

Figure 3.9-2 Intake Manifold Heater Removal

# **TURBONutter**

Lada Niva 4x4  
Service Manual  
Fuel Injection

This manual and a host of other wonderful Lada Niva documentation is available free of charge at:

<http://www.turbo-nutter.com>

You can do anything you like with this manual except sell it or otherwise make money from it.

While I can't stop you sticking it on your own website I would much prefer you linked to its original location on turbo-nutter.com

You use the information contained with this manual at you own risk. If you're not sure how to do something either don't do it or ask someone who knows about such things. The font of all Lada knowledge can be found at:

<http://www.lada.co.uk/forum>

For Lada parts, advice and general all round Lada wonderfulness these blokes aren't bad:

Lada UK Ltd  
Askew Rigg  
Troutbeck  
Penrith, Cumbria  
CA11 0SZ  
United Kingdom

T: +44 (0) 17 6877 9794  
F: +44 (0) 17 6877 9197  
E: [alan@lada.co.uk](mailto:alan@lada.co.uk)  
W: <http://www.lada.co.uk>

Lada Parts Australia P/L  
42 Aerodrome Road  
Caboolture  
Queensland  
4510  
Australia

T: +61 7 5495 5100  
F: +61 7 5495 5152  
E: [andy@ladaparts.com](mailto:andy@ladaparts.com)  
W: <http://www.ladaparts.com>



## 4. SPECIFICATIONS

### 1.7L THROTTLE BODY INJECTION

#### IGNITION

|                                    |                       |
|------------------------------------|-----------------------|
| CRANK SENSOR COIL RESISTANCE ..... | 500-700 OHMS          |
| IGNITION COIL                      |                       |
| PRIMARY RESISTANCE .....           | 0.35-1.45 OHMS        |
| SECONDARY RESISTANCE .....         | 5000-6500 OHMS        |
| SECONDARY WIRE RESISTANCE .....    | LESS THAN 15,000 OHMS |

IGNITION TIMING IS CONTROLLED BY THE ELECTRONIC CONTROL MODULE AND IS NOT ADJUSTABLE.

#### FUEL

|  |  |
|--|--|
| THROTTLE BODY INJECTION FUEL SYSTEM PRESSURE<br>(WITH IGNITION "ON," ENGINE RUNNING) ..... | 190-210 kPa<br>(27-30 psi; 1.9-2.1 bar)                |
| THROTTLE BODY INJECTION FUEL INJECTOR RESISTANCE .....                                     | 1.42 TO 2.0Ω WHEN<br>MEASURED BETWEEN<br>20°C and 50°C |

IDLE SPEED IS CONTROLLED BY THE ELECTRONIC CONTROL MODULE. WHEN ENGINE IS WARM, IDLE SPEED SHOULD BE WITHIN 50 REVOLUTIONS PER MINUTE\* OF DESIRED IDLE SPEED.

\* SEE TECH 1 SCAN DATA VALUES.

## 5. TORQUE SPECIFICATIONS

### 1.7L THROTTLE BODY INJECTION

#### TORQUE SPECIFICATIONS

|   |                       |
|---|-----------------------|
| THROTTLE BODY INJECTION ATTACH. BOLT/STUDS .....                                | 17.0 N·m (12 lb. ft.) |
| FUEL LINE NUTS AT CONNECTION POINT TO<br>THROTTLE BODY INJECTION ASSEMBLY ..... | 27.0 N·m (20 lb. ft.) |
| FUEL LINE NUTS AT FUEL FILTER .....   | 27.0 N·m (20 lb. ft.) |
| FUEL PRESSURE REGULATOR COVER .....   | 2.5 N·m (22 lb. in.)  |
| FUEL METER BODY-THROTTLE BODY .....   | 6.0 N·m (53 lb. in.)  |
| THROTTLE BODY INJECTION FUEL INLET NUT .....                                    | 27.0 N·m (20 lb. ft.) |
| THROTTLE BODY INJECTION FUEL OUTLET NUT .....                                   | 27.0 N·m (20 lb. ft.) |
| THROTTLE POSITION SENSOR .....  | 2.0 N·m (18 lb. in.)  |
| IDLE AIR CONTROL VALVE .....  | 1.5 N·m (13 lb. in.)  |
| TUBE MODULE ASSEMBLY .....  | 3.0 N·m (28 lb. in.)  |
| INJECTOR RETAINER SCREW .....   | 3.0 N·m (28 lb. in.)  |
| COOLANT TEMPERATURE SENSOR .....  | 14.0 N·m (10 lb. ft.) |
| INTAKE AIR TEMPERATURE SENSOR .....   | 14.0 N·m (10 lb. ft.) |
| SPARK PLUGS .....   | 15.0 N·m (11 lb. ft.) |

## 6. SPECIAL TOOLS

## 1.7L THROTTLE BODY INJECTION

Special diagnostic service tools that are mentioned in this service manual and described below are available for worldwide distribution from:

Kent-Moore  
 SPX Corporation  
 29784 Little Mack  
 Roseville, MI 48066-2298  
 1-800-345-2233  
 Monday through Friday  
 8:00 a.m. through 8:00 p.m. EST  
 Telex: 244040 KMTR UR  
 Fax: 313-578-7375

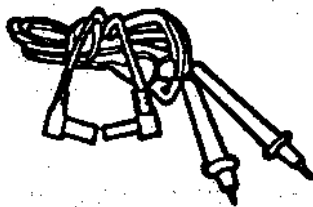
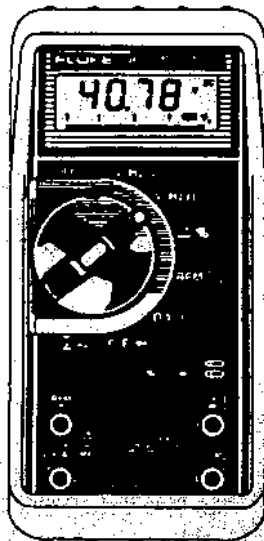

DIGITAL MULTIMETER

J 39689-78

**VOLTMETER**—Voltage position V measures magnitude of voltage when connected in parallel to an existing circuit. A digital voltmeter with a 10 megohm input impedance is used because this type of meter will not load down the circuit and result in faulty readings. Some circuits require accurate low resistance. Direct Current Voltage measurement selection V is used for most automotive measurements.

**AMMETER**—When used as an ammeter, this meter accurately measures extremely low current flow. Refer to meter instructions for more information.

- Selector must be set properly for both function and range. Direct Current measurement selection A is used for most automotive measurements.

**OHMMETER**—Measurement selection “Ω” measures resistance of circuit directly in ohms. Refer to meter instructions for more information.

- Overload display “OL” in all ranges indicates open circuit.
- Zero display in all ranges indicates a short circuit.
- An intermittent connection in a circuit may be indicated by a digital reading that will not stabilize on the circuit.

**FREQUENCY**—Position Hz measures frequency of AC or pulsed DC voltages.

**TEMPERATURE**—Position °C °F, measures temperature using the included thermocouple probe.







**DWELL-DUTY CYCLE**—Position  $\Delta$  % measures dwell or duty cycle of pulse with modulated signals.

**ENGINE SPEED**—Position RPM measures engine speed. See meter sample for symbol.

12-21-92  
 NS 14431

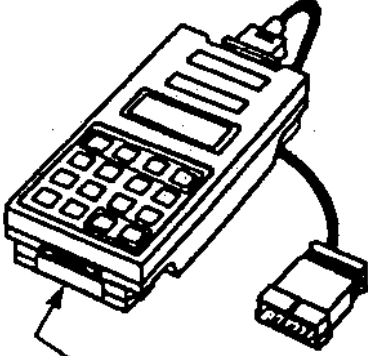
Special Tools (1 of 4)

## 6-2 ENGINE MANAGEMENT SYSTEMS 1.7L THROTTLE BODY INJECTION

|  |   |
|--|---|
|  <p style="text-align: right;"><b>J 38970-V</b></p>   | <p><b>FUEL PRESSURE GAGE KIT</b></p> <p>Used for checking and monitoring fuel line pressure of both throttle body fuel injection and port fuel injection. Includes one (1) Diagnostic Test fitting, needed to test the fuel pressure on the throttle body fuel injection system at the outlet fitting of the fuel filter.</p> |
|  <p style="text-align: right;"><b>J 34730-2A</b></p>  | <p><b>INJECTOR CIRCUIT TEST LIGHT</b></p> <p>Used for testing fuel injector circuits on both throttle body injection and port fuel injection systems. This is packaged in the J 35616-V connector test adapter kit.</p>   |
|    | <p><b>TECH 1 DIAGNOSTIC COMPUTER</b></p> <p>A hand-held scan tool used to analyze and diagnose fuel and emission system.</p>  |
|   | <p><b>TECH 1 VAZ TESTER CARTRIDGE</b></p> <p>The Tech 1 tester cartridge is a VAZ specific cartridge that allows the Tech 1 tool to test the VAZ fuel injection system.</p>   |
|  <p style="text-align: right;"><b>J 35616-V</b></p> | <p><b>CONNECTOR TEST ADAPTER KIT</b></p> <p>Used for making electrical test connections in current Weather Pack, Metri-Pack, and Micro-Pack style terminals. The secondary ignition spark tester part number J 26792 (ST 125) and injector circuit test light J 34730-2A are included in this kit.</p>                        |
|  <p style="text-align: right;"><b>J 26792</b></p>   | <p><b>SECONDARY IGNITION VOLTAGE TESTER</b></p> <p>Used for checking available secondary ignition voltage. Also called an ST 125. This spark tester is packaged in the connector test adapter kit #J 35616-V.</p>   |

4-28-93  
NS 14432

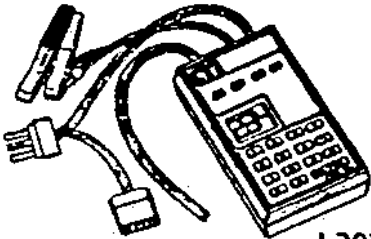
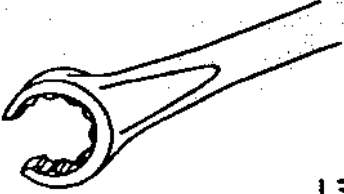
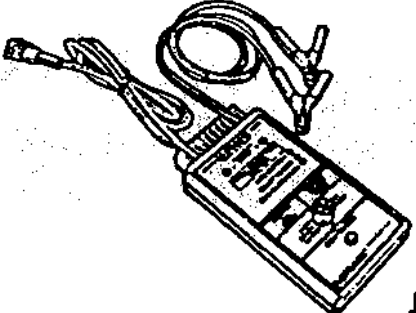
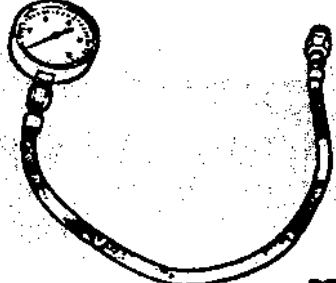
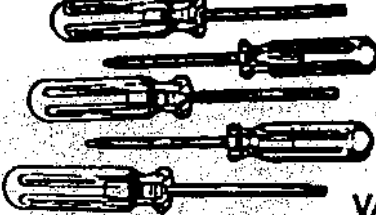
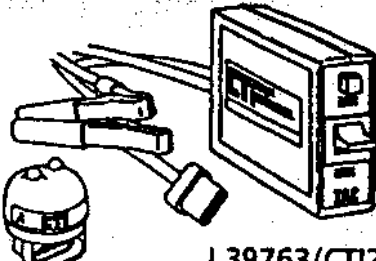

Special Tools (2 of 4)

|   |   |
|---|---|
|  <p>J 39764/CTI234</p>     | <p><b>MANIFOLD ABSOLUTE PRESSURE SENSOR TESTER</b></p> <p>Allows accurate testing of the manifold absolute pressure sensor. The tester compares the output voltage signal of the vehicle sensor to the tool's own calibrated standard sensor.</p>   |
|  <p>J 39194-V</p>          | <p><b>EXHAUST OXYGEN SENSOR WRENCH</b></p> <p>Used to remove and install the oxygen sensor which is used on this system.</p>  |
|  <p>J 39021-V</p>         | <p><b>FUEL INJECTOR TESTER KIT</b></p> <p>Connector harness adapters from twist lock connector to :</p> <ul style="list-style-type: none"> <li>• Throttle Body Injector, 700 Injector (J 39021-30)</li> <li>• Port Fuel Injector (J 39021-20)</li> <li>• Injector Switch Box (J 39021-10), for testing Port Fuel Injectors without removal from VAZ Port Fuel Injection engines.</li> </ul> |
|  <p>BT-8515-V</p>        | <p><b>EXHAUST SYSTEM BACKPRESSURE TESTER</b></p> <p>Used to test for plugged or restricted exhaust system components, particularly the catalytic converter.</p>   |
|  <p>VA 70433</p>         | <p><b>TORX FASTENER REMOVAL/INSTALLATION KIT</b></p> <p>Torx fastener removal/installation tool kit, for fuel system components.</p>  |
|  <p>J 39763/CTI222DM</p> | <p><b>IDLE AIR CONTROL SYSTEM MONITOR</b></p> <p>Used to test idle air control motors for correct functioning and proper response to commands.</p>  |

4-28-93  
NS 14435

Special Tools (3 of 4)

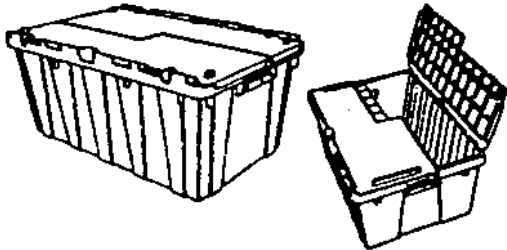
6-4 ENGINE MANAGEMENT SYSTEMS 1.7L THROTTLE BODY INJECTION

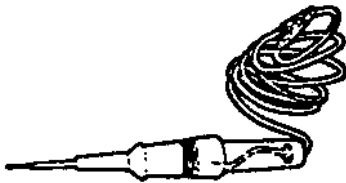
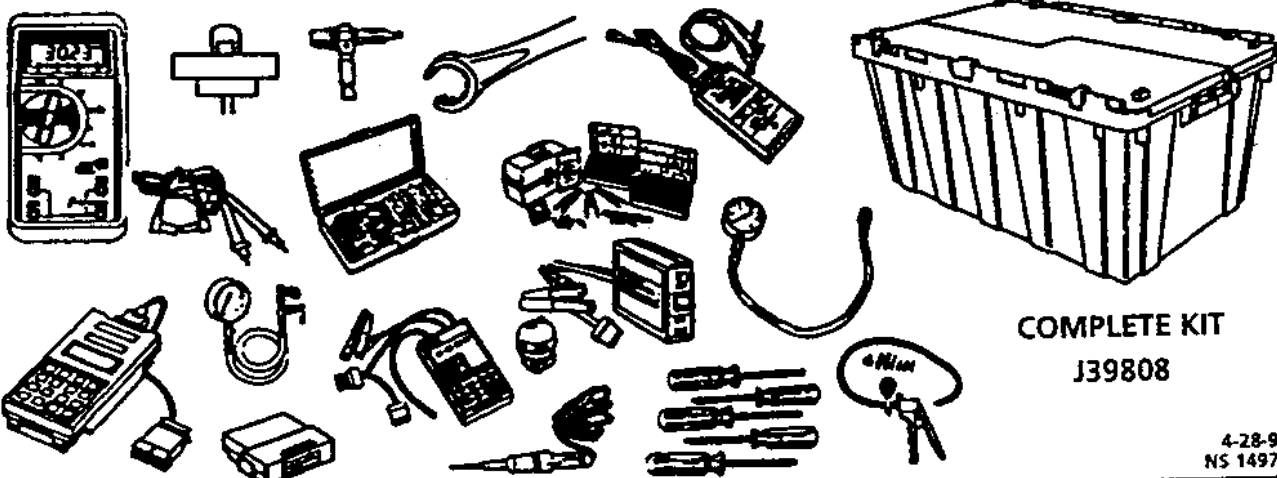
|  |   |
|--|---|
|  <p>J 35805</p>   | <p><b>PLASTIC CONTAINER</b><br/>Plastic container, lockable to contain all tools mentioned on the previous pages.</p>   |
|  <p>J 39745</p>   | <p><b>TERMINAL REPAIR KIT</b><br/>Contains proper tools and components to perform reliable wiring repairs to the engine management system wiring harness.</p> |
|  <p>J 35555</p>  | <p><b>VACUUM PUMP WITH GAGE</b><br/>Use the gage to monitor manifold engine vacuum and use the hand pump to check vacuum sensors, solenoids and valves.</p>   |
|  <p>J 34142-B</p>   | <p><b>UNPOWERED TEST LIGHT</b><br/>Used in checking wiring for a complete circuit, short to ground, or voltage.</p>   |
|  <p><b>COMPLETE KIT</b><br/>J39808</p> <p>4-28-93<br/>NS 14973</p> |   |

Special Tools (4 of 4)