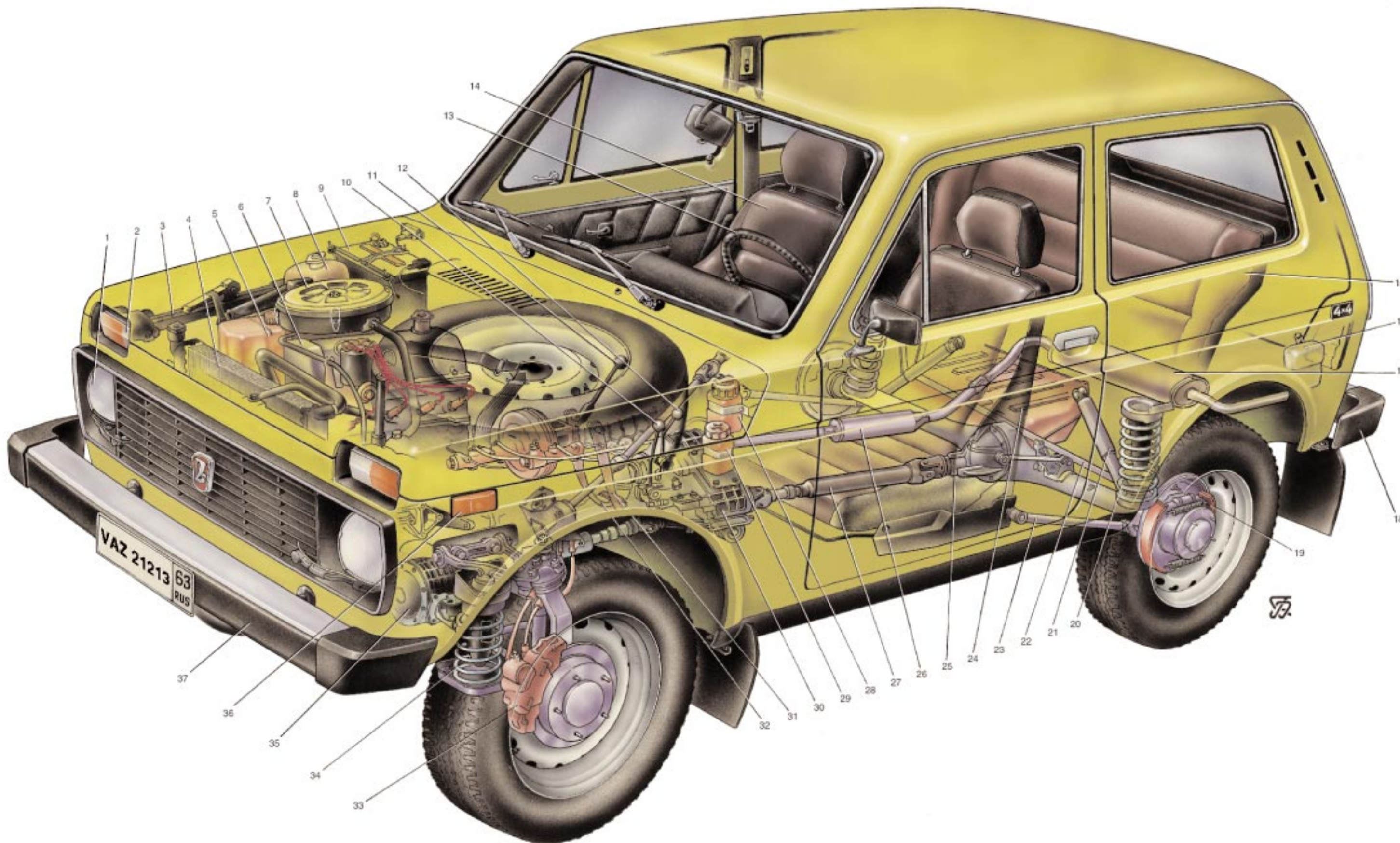

ILLUSTRATION ALBUM

VAZ - 21213, VAZ - 21214

CONTENTS

VEHICLE PACKAGING	2
ENGINE (sectional view)	3
ENGINE (cross-sectional view)	4
Components of crank mechanism and timing gear.	5
ENGINE LUBRICATION SYSTEM.	6
COOLING SYSTEM	7
FUEL SYSTEM.	8
CARBURETTOR.	9
CARBURETTOR OPERATION DIAGRAM.	10
AIR CLEANER. SILENCERS.	11
CLUTCH.	12
CLUTCH OPERATION SYSTEM.	13
GEARBOX	14
GEARBOX OPERATION DIAGRAM	15
PROPELLER SHAFT	16
TORQUE CONVERTER AND ITS DRIVE SYSTEM.	17
TORQUE CONVERTER OPERATION DIAGRAM	18
REAR AXLE	19
FRONT AXLE	20
FRONT SUSPENSION	21
REAR SUSPENSION	22
SHOCK ABSORBERS	23
STEERING	24
BRAKE MECHANISM	25
BRAKE OPERATION DIAGRAM	26
WIRING DIAGRAM FOR ELECTRICAL EQUIPMENT OF VAZ 21213 VEHICLE. .	27
ALTERNATOR	28
ALTERNATOR 94.3701 (FOR INJECTION VEHICLES)	29
STARTER MOTOR	30
IGNITION SYSTEM	31
WINDSCREEN WIPER	32
BODY	33
BODY FITTINGS.	34
HEATING AND VENTILATION. WIPER/WASHER.	35
INJECTION SYSTEM (GM).	36
INJECTION SYSTEM DIAGRAM (GM)	37
WIRING DIAGRAM FOR INJECTION SYSTEM (GM)	38
WIRING DIAGRAM FOR INJECTION SYSTEM EURO2.	39
WIRING DIAGRAM FOR INJECTION SYSTEM EURO3	40



VEHICLE PACKAGING

Specification

Payload, kg 400
 Kerbweight, kg 1210
 Max. speed, km/h 137
 Acceleration time from 0 to 100 km/h,
 with gearchange, on GVW vehicle, sec . . 21

Overall dimensions, mm:

length 3740
 width 1680
 unladen height 1640
 Wheelbase, mm 2200
 Track:
 front, mm 1430
 rear, mm 1400

- | | | | |
|--------------------------------------------------|---------------------------------------|---------------------------------------------|---------------------------------------------|
| 1. Headlight | 11. Gear change lever | 21. Rear shock - absorber | 31. Clutch pedal |
| 2. Front lamp | 12. Gear change lever in transfer box | 22. Rear suspension transverse torque rod | 32. Brake pedal |
| 3. Jack | 13. Steering wheel | 23. Rear suspension longitudinal torque rod | 33. Front brake |
| 4. Radiator | 14. Front seat | 24. Fuel tank | 34. Front suspension coil spring |
| 4. Windscreen / headlight washer fluid reservoir | 15. Rear seat | 25. Rear axle | 35. Front axle |
| 6. Engine | 16. Tailgate washer fluid reservoir | 26. Intermediate silencer | 36. Direction indicator side repeater light |
| 7. Air cleaner | 17. Main silencer | 27. Rear propeller shaft | 37. Front bumper |
| 8. Cooling system expansion tank | 18. Rear bumper | 28. Reservoir for brake hydraulic fluid | |
| 9. Battery | 19. Rear brakes | 29. Reservoir for clutch hydraulic fluid | |
| 10. Differential lock lever in transfer box | 20. Rear suspension coil spring | 30. Torque converter | |

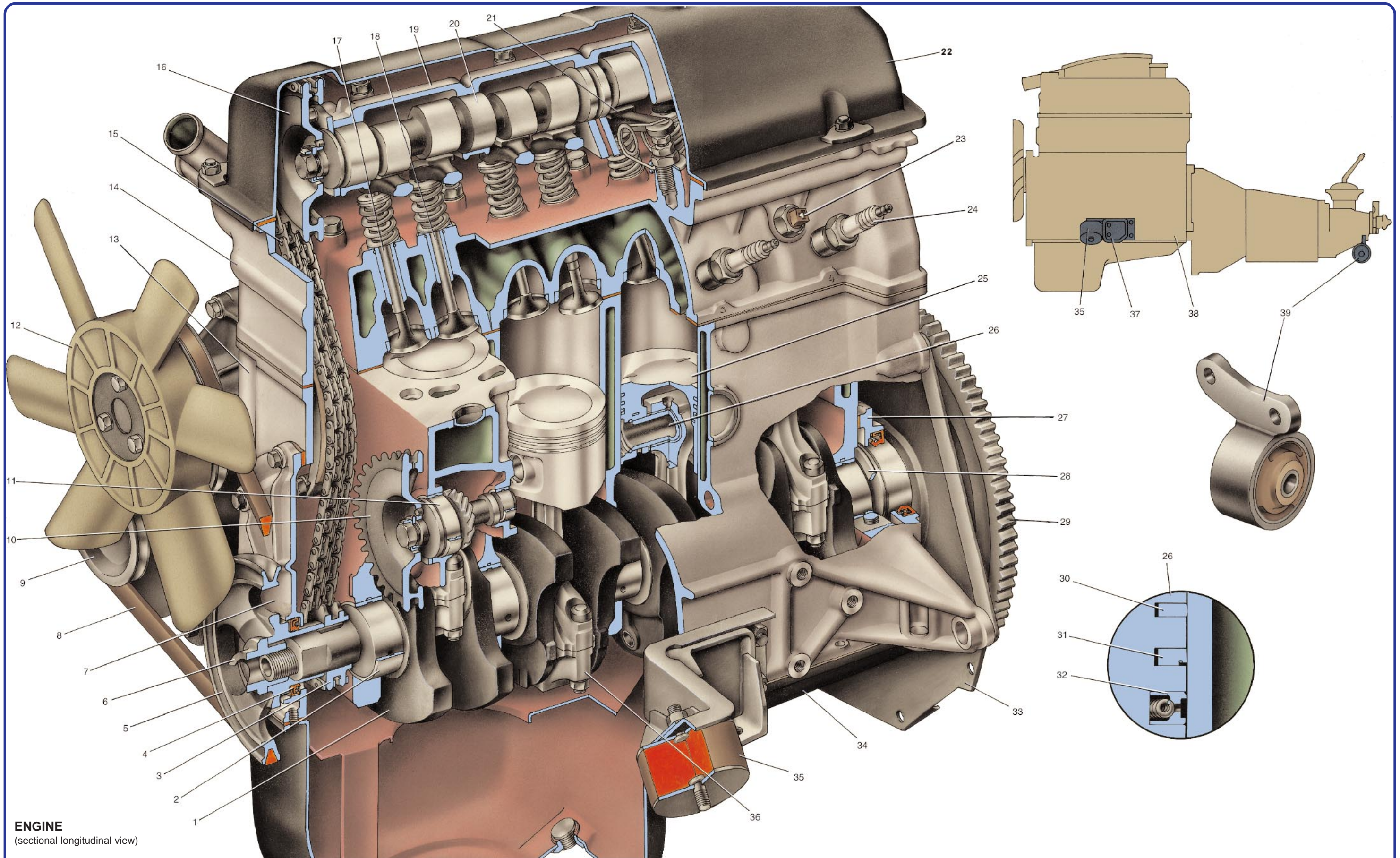

ENGINE
(sectional longitudinal view)

Specification

Engine model VAZ - 21213
 Cylinder bore and piston stroke, mm. 80 x 80
 Displacement, l 1.69
 Compression ratio 9.3
 Rated power as per GOST 14846-89 (net)
 and ISO 1585-82 at crankshaft rate
 5,200 rpm, kW (HP) 59 (80.2)

- | | | | | |
|-------------------------------------------------------------------------------------------------------------------------------------------------------------------------------------------------------------------------------------------------------------------------------------------------------------------------------|------------------------------------------------------------------------------------------------------------------------------------------------------------------------------------------------------------------------------------------------------------------------------------------------------------------------------------------------|----------------------------------------------------------------------------------------------------------------------------------------------------------------------------------------------------------------------------------------------------------------------------------------------------------------|-------------------------------------------------------------------------------------------------------------------------------------------------------------------------------------------------------------------------------------------------------------------------------------------------------------------------------------------------|---------------------------------------------------------------------------------------------------------------------------------------------------------------------------------------------------------------|
| <ul style="list-style-type: none"> 1. Crankshaft 2. Main bearing shell 3. Crankshaft sprocket 4. Crankshaft front oil seal 5. Crankshaft pulley 6. Ratchet 7. Timing cover 8. Coolant pump / alternator drivebelt 9. Alternator pulley | <ul style="list-style-type: none"> 10. Oil pump / ignition distributor / fuel tank / drive sprocket 11. Oil pump / ignition distributor / fuel tank drive shaft 12. Engine cooling system fan 13. Cylinder block 14. Cylinder head 15. Timing chain 16. Camshaft sprocket | <ul style="list-style-type: none"> 17. Exhaust valve 18. Inlet valve 19. Camshaft bearing housing 20. Camshaft 21. Valve operating lever 22. Valve cover 23. Coolant temperature gauge sender 24. Spark plug 25. Piston | <ul style="list-style-type: none"> 26. Gudgeon pin 27. Crankshaft rear oil seal retainer 28. Crankshaft thrust half-ring 29. Flywheel 30. Upper compression ring 31. Lower compression ring 32. Oil ring 33. Clutch bellhousing cover plate 34. Oil sump | <ul style="list-style-type: none"> 35. Power unit front mounting 36. Connecting rod 37. Front mounting bracket 38. Power unit 39. Power unit rear mounting |
|-------------------------------------------------------------------------------------------------------------------------------------------------------------------------------------------------------------------------------------------------------------------------------------------------------------------------------|------------------------------------------------------------------------------------------------------------------------------------------------------------------------------------------------------------------------------------------------------------------------------------------------------------------------------------------------|----------------------------------------------------------------------------------------------------------------------------------------------------------------------------------------------------------------------------------------------------------------------------------------------------------------|-------------------------------------------------------------------------------------------------------------------------------------------------------------------------------------------------------------------------------------------------------------------------------------------------------------------------------------------------|---------------------------------------------------------------------------------------------------------------------------------------------------------------------------------------------------------------|

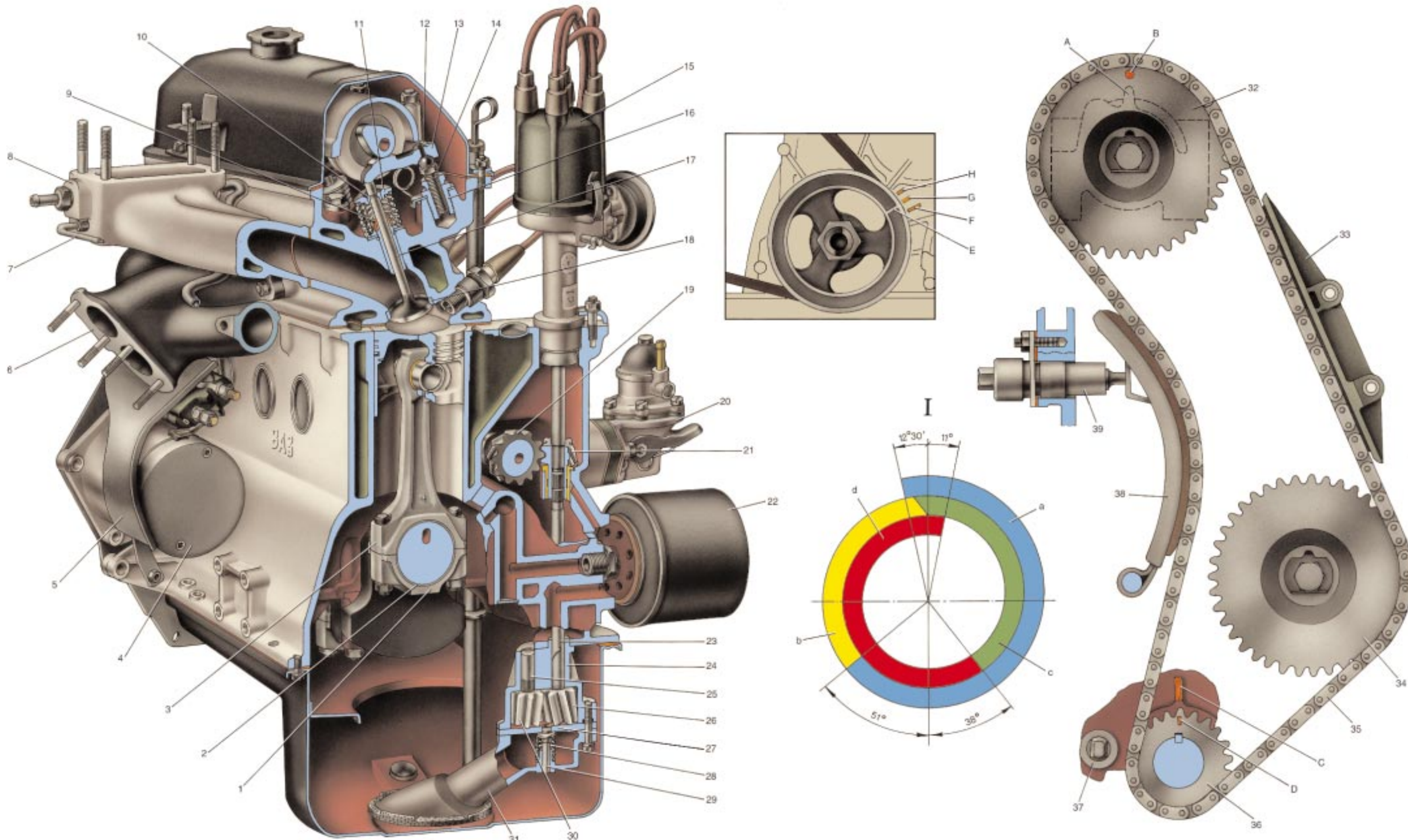

ENGINE
(cross-sectional view)

- 1. Big end cap
- 2. Shell bearing
- 3. Connecting rod
- 4. Starter motor
- 5. Starter motor heat shield
- 6. Exhaust manifold
- 7. Inlet pipe drain tube
- 8. Inlet pipe

- 9. Oil deflector cap
- 10. Valve collet
- 11. Valve spring cap
- 12. Valve operating lever spring
- 13. Valve operating lever
- 14. Valve adjuster bolt
- 15. Ignition distributor
- 16. Adjuster bolt bush
- 17. Valve guide
- 18. Valve seat

- 19. Oil pump / ignition distributor / fuel pump drive shaft
- 20. Fuel pump
- 21. Oil pump / ignition distributor drive gear
- 22. Oil filter
- 23. Oil pump drive shaft
- 24. Oil pump body
- 25. Oil pump driven gear shaft
- 26. Oil pump drive gear
- 27. Oil pump cover
- 28. Reducing valve spring

- 29. Reducing valve
- 30. Oil pump driven gear
- 31. Oil pump inlet pipe
- 32. Camshaft sprocket
- 33. Chain damper
- 34. Oil pump / ignition distributor / fuel pump drive sprocket
- 35. Valve chain
- 36. Crankshaft sprocket
- 37. Chain stop pin
- 38. Chain tensioner shoe

- 39. Chain tensioner

- I. Firing order
- a. Induction
- b. Compression
- c. Power
- d. Exhaust

- A. Mounting lug on camshaft bearing housing
- B. Camshaft sprocket timing mark
- C. Cylinder block timing mark
- D. Timing mark on crankshaft sprocket
- E. TDC pointer on crankshaft pulley
- F. 0° timing mark
- G. 5° timing mark
- H. 10° timing mark

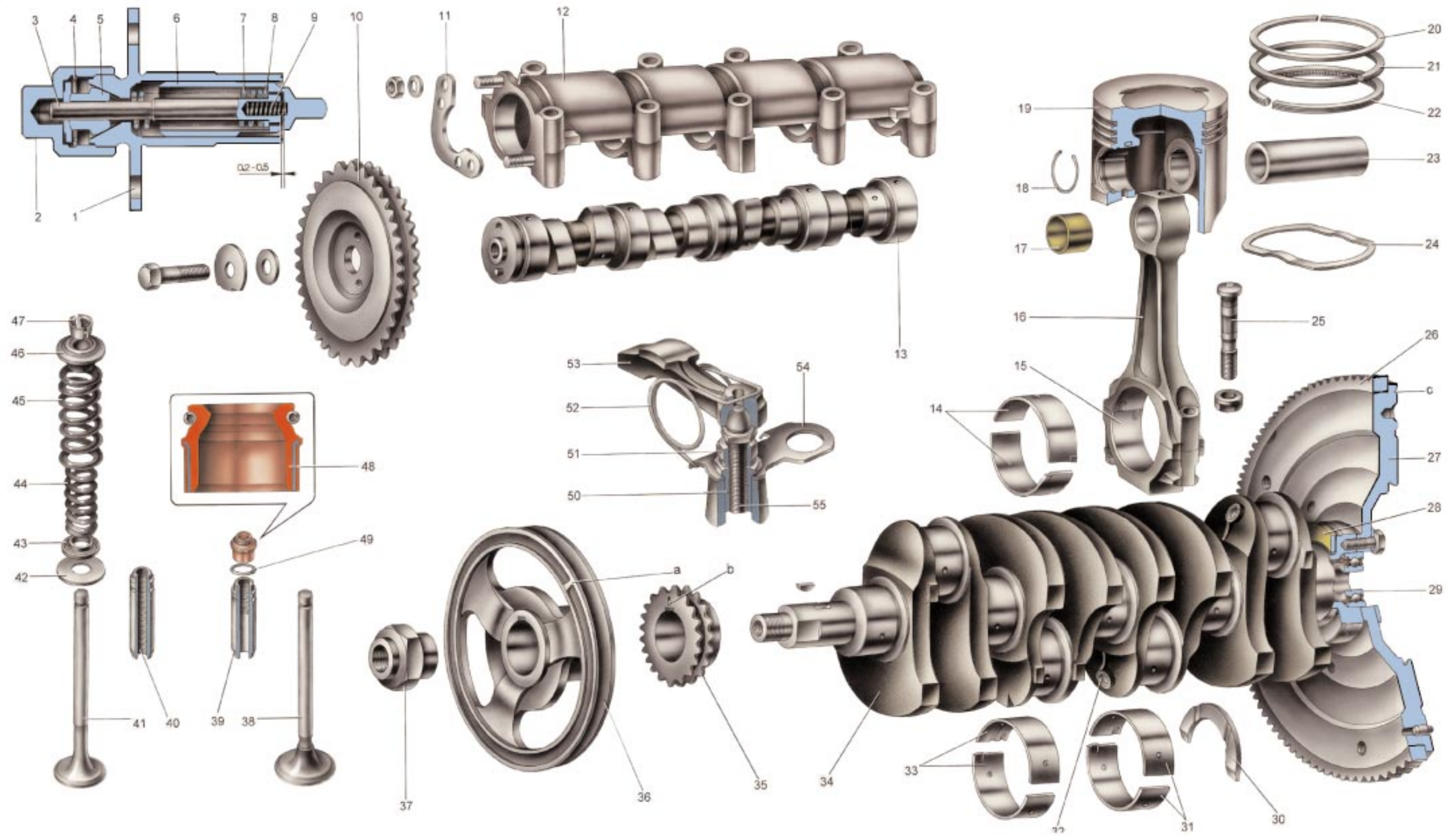

COMPONENTS OF CRANK MECHANISM AND TIMING GEAR

- 1. Tensioner housing
- 2. Cap nut
- 3. Tensioner rod
- 4. Circlip
- 5. Clamping block
- 6. Plunger
- 7. Spring, tensioner
- 8. Washer

- 9. Spring, plunger
- 10. Camshaft sprocket
- 11. Thrust flange
- 12. Camshaft bearing housing
- 13. Camshaft
- 14. Big-end bearing shells
- 15. Big end cap
- 16. Connecting rod
- 17. Bush, conrod small end
- 18. Circlip
- 19. Piston

- 20. Top compression ring
- 21. Bottom compression ring
- 22. Oil ring
- 23. Gudgeon pin
- 24. Thermoregulator plate
- 25. Bolt, conrod
- 26. Starter ring gear
- 27. Flywheel
- 28. Thrust half-ring, rear
- 29. Front bearing, gearbox input shaft
- 30. Thrust half-ring, front

- 31. Centre main bearing (No 3) shells
- 32. Crankshaft oil gallery plug á
- 33. 1st, 2nd, 4th and 5th crankshaft bearing shells
- 34. Crankshaft
- 35. Crankshaft sprocket
- 36. Alternator drive / coolant pump pulley
- 37. Nut
- 38. Inlet valve
- 39. Inlet valve guide
- 40. Exhaust valve guide
- 41. Exhaust valve

- 42. Seat, outer spring
- 43. Seat, inner spring
- 44. Inner valve spring
- 45. Outer valve spring
- 46. Spring seat
- 47. Valve collet
- 48. Outer cap
- 49. Circlip
- 50. Washer, adjusting bolt
- 51. Locknut
- 52. Spring

- 53. Push rod
- 54. Stop plate, push rod spring
- 55. Adjusting bolt, valve

a, b, c – TDC marks, 1st and 4th cylinder pistons

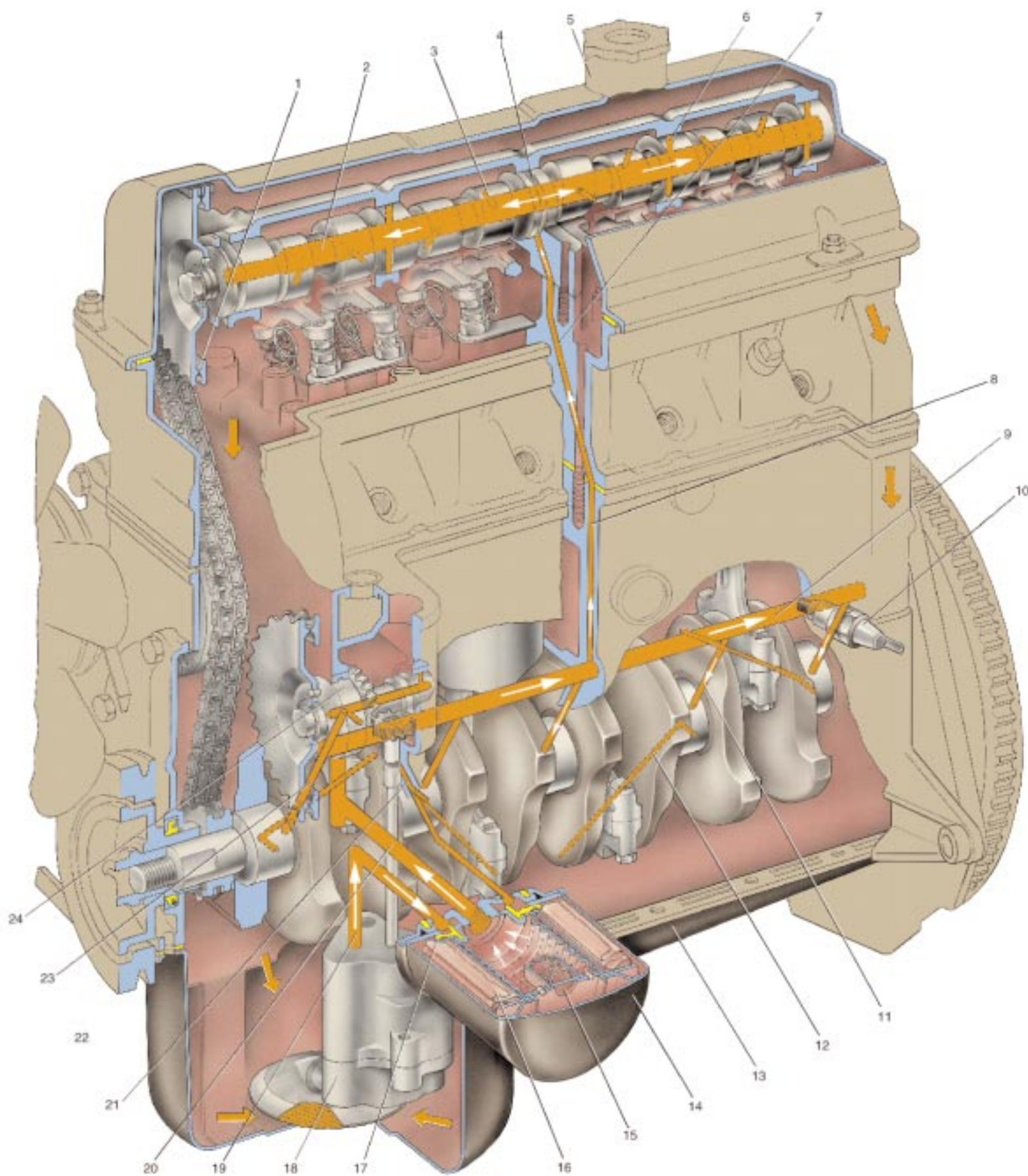

ENGINE LUBRICATION SYSTEM

1. Sprocket hole for chain lubrication
2. Camshaft main oil gallery
3. Cam lobe oilway
4. Camshaft centre bearing journal oil recess
5. Oil filler neck
6. Camshaft journal oilway
7. Inclined oilway in cylinder head

8. Oilway to timing gear
9. Cylinder block main oil gallery
10. Oil pressure warning light sender
11. Oilway to main bearing
12. Oilway to big end bearing
13. Oil sump
14. Oil filter
15. By-pass valve
16. Paper filter element

17. Check valve
18. Oil pump
19. Oil pump - to - oil filter gallery
20. Oilway from oil filter to main oil gallery
21. Oilway to oil pump drive gear bush
22. Front crankshaft grease seal
23. Oilway to main bearing and to oil pump drive gear shaft
24. Oil pump / ignition distributor drive shaft

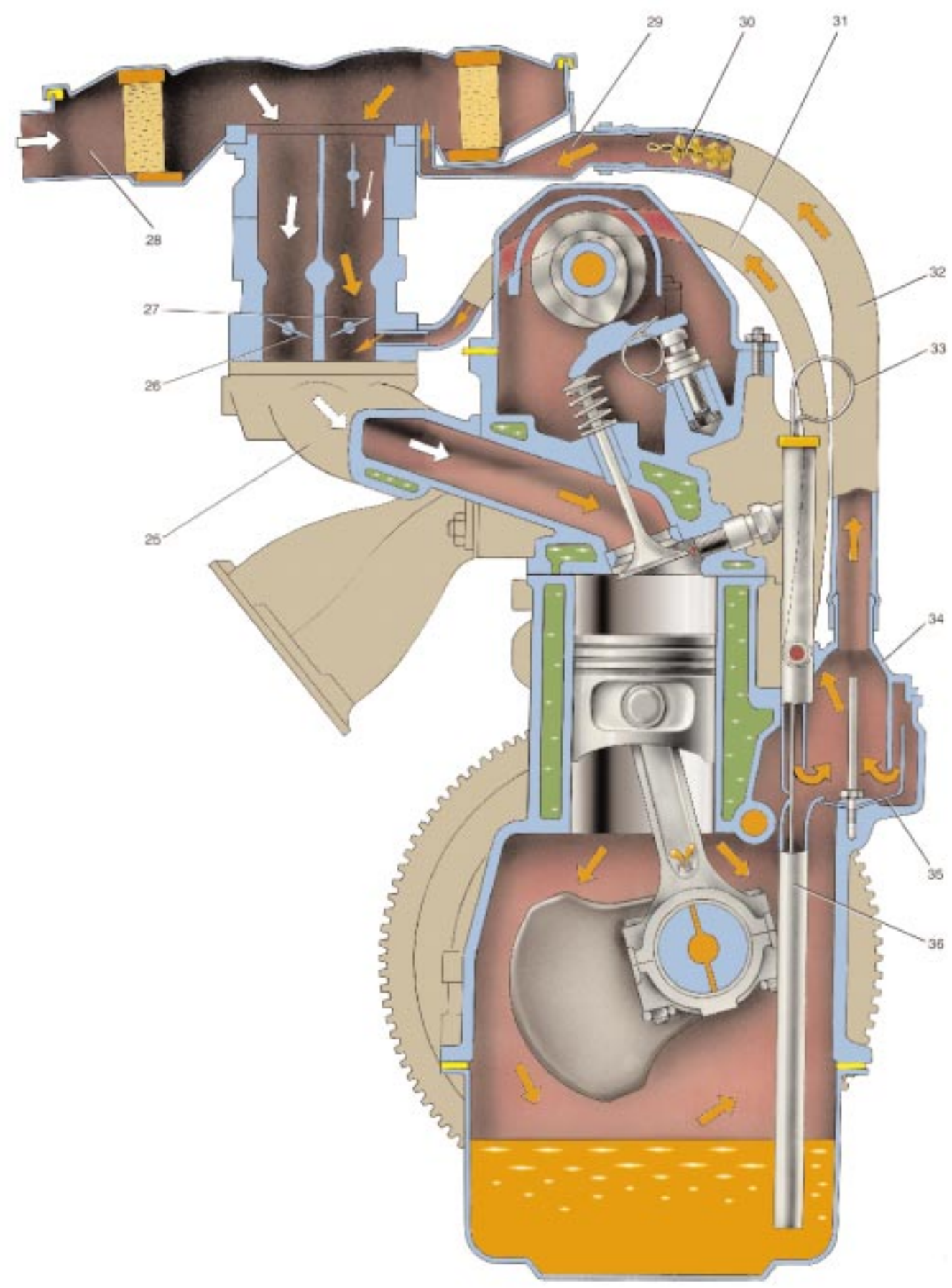

25. Inlet pipe
26. Throttle valve, carburettor secondary barrel
27. Throttle valve, carburettor primary barrel
28. Air cleaner unit
29. Discharge ventilation manifold
30. Flame arrester
31. Hose to draw crankcase gases behind carburettor throttle valve
32. Discharge hose

33. Oil level dipstick
34. Oil separator cover
35. Oil separator
36. Drain pipe

I. Engine crankcase ventilation diagram

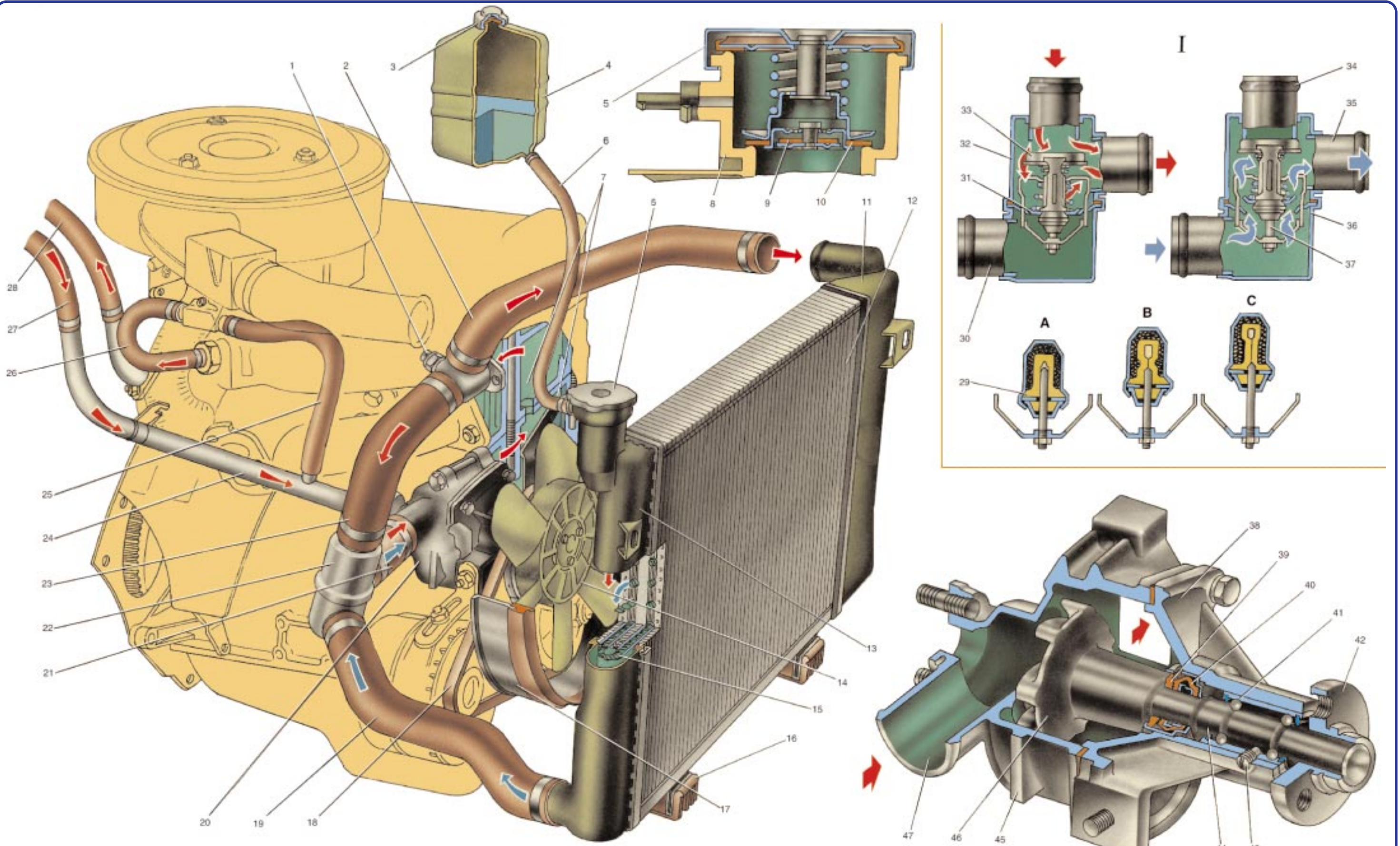

COOLING SYSTEM

- | | | | | | |
|-------------------------------------------------|------------------------------|-----------------------------------------------------------|----------------------------------------------|-----------------------------------------|----------------|
| 1. Temperature sensor for fuel injection system | 9. Inlet valve | 19. Radiator outlet hose | 27. Coolant return hose from heater radiator | 37. Piston | 47. Inlet pipe |
| 2. Radiator top hose | 10. Exhaust (steam) valve | 20. Coolant pump | 28. Coolant supply hose to heater radiator | 38. Water pump cover | |
| 3. Expansion tank filler cap | 11. LH fluid cooler | 21. Coolant pump supply hose | 29. Rubber insert | 39. Oil seal thrust sealing ring | |
| 4. Expansion tank | 12. Radiator matrix | 22. Thermostat | 30. Inlet elbow (from radiator) | 40. Oil seal collar | |
| 5. Radiator cap | 13. RH fluid cooler | 23. Thermostat by-pass hose | 31. Main valve | 41. Water pump shaft bearing outer ring | |
| 6. Fluid return hose to expansion tank | 14. Fan impeller | 24. Coolant return hose from heater radiator | 32. Thermostat housing | 42. Fan pulley hub | |
| 7. Cooling water jacket | 15. Swirler | 25. Coolant return pipe from part throttle channel heater | 33. By-pass valve | 43. Stop screw | |
| 8. Filler neck | 16. Radiator mounting rubber | 26. Coolant supply hose to part throttle channel heater | 34. By-pass hose pipe | 44. Water pump shaft | |
| | 17. Fan cowl | | 35. Coolant pump supply pipe | 45. Water pump housing | |
| | 18. Fan belt | | 36. Thermostat cover | 46. Water pump impeller | |

I. Thermostat operation diagram
 A. Coolant temperature below 80°C
 B. Coolant temperature within 80 to 94°C
 C. Coolant temperature over 94°C.

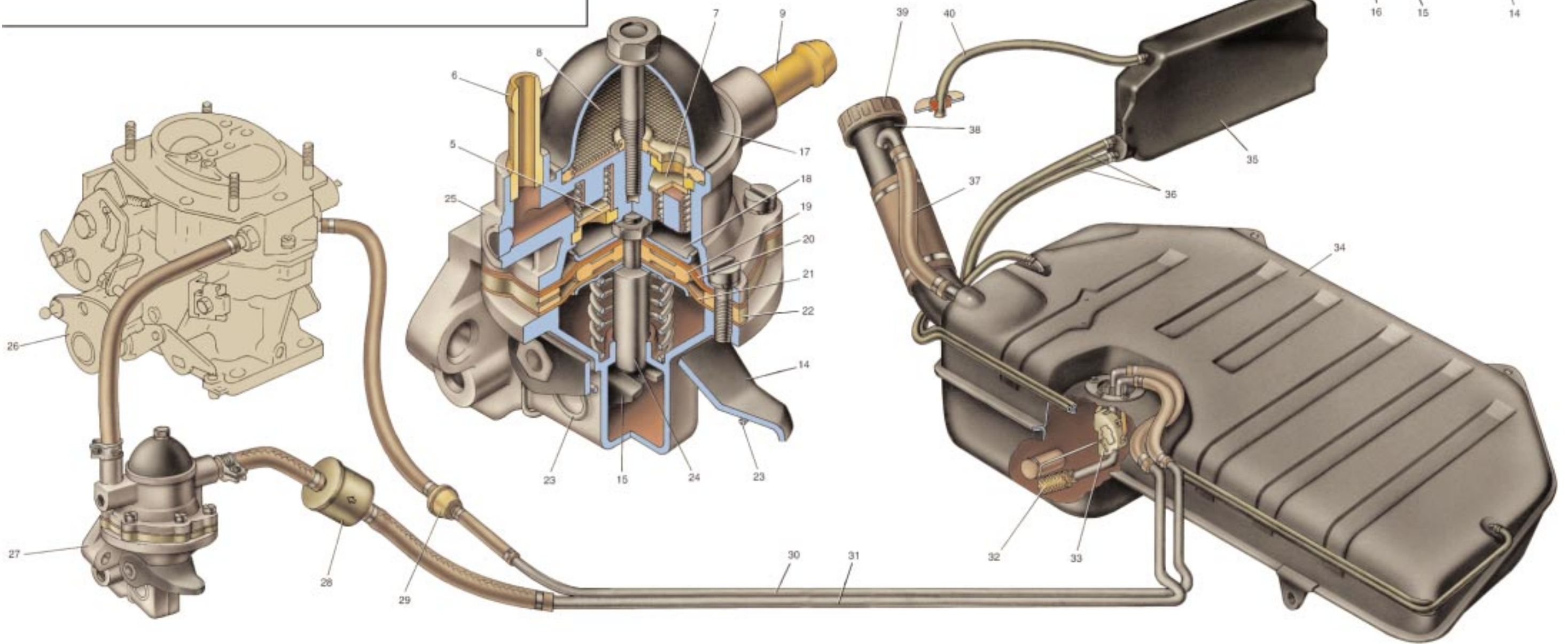

FUEL SYSTEM

- 1. Rocker arm shaft
- 2. Rocker arm
- 3. Pushrod
- 4. Bottom cover
- 5. Delivery valve
- 6. Delivery union

- 7. Suction valve
- 8. Fuel filter
- 9. Suction union
- 10. Fuel pump eccentric on shaft 19 (See p.4)
- 11. Thermal insulating spacer
- 12. Gasket
- 13. Fuel tank shim
- 14. Priming lever
- 15. Rocker

- 16. Eccentric
- 17. Fuel tank cover
- 18. Diaphragm plate
- 19. Inner spacer
- 20. Upper diaphragms
- 21. Lower diaphragm
- 22. Outer spacer
- 23. Return spring
- 24. Pullrod

- 25. Top cover
- 26. Carburettor
- 27. Fuel pump
- 28. Fine filter
- 29. Check valve
- 30. Return flow line
- 31. Supply line from fuel tank
- 32. Intake pipe filter
- 33. Fuel gauge sender

- 34. Fuel tank
- 35. Fuel vapour separator
- 36. Separator connecting hoses
- 37. Air hose
- 38. Fuel filler neck
- 39. Filler cap
- 40. Vent hose

- I. Fuel pump operation diagram
- II. Fuel pump mounting diagram

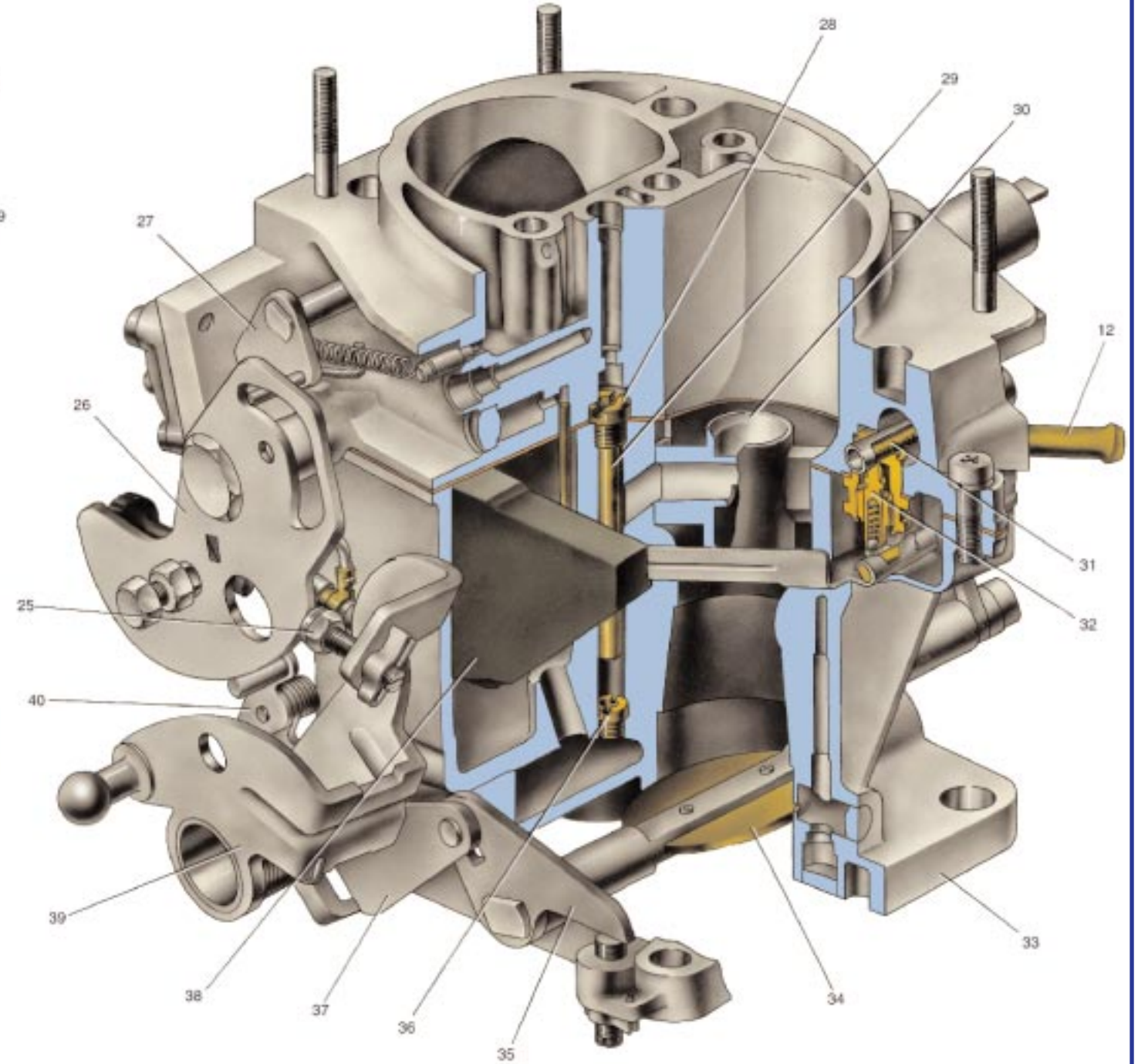
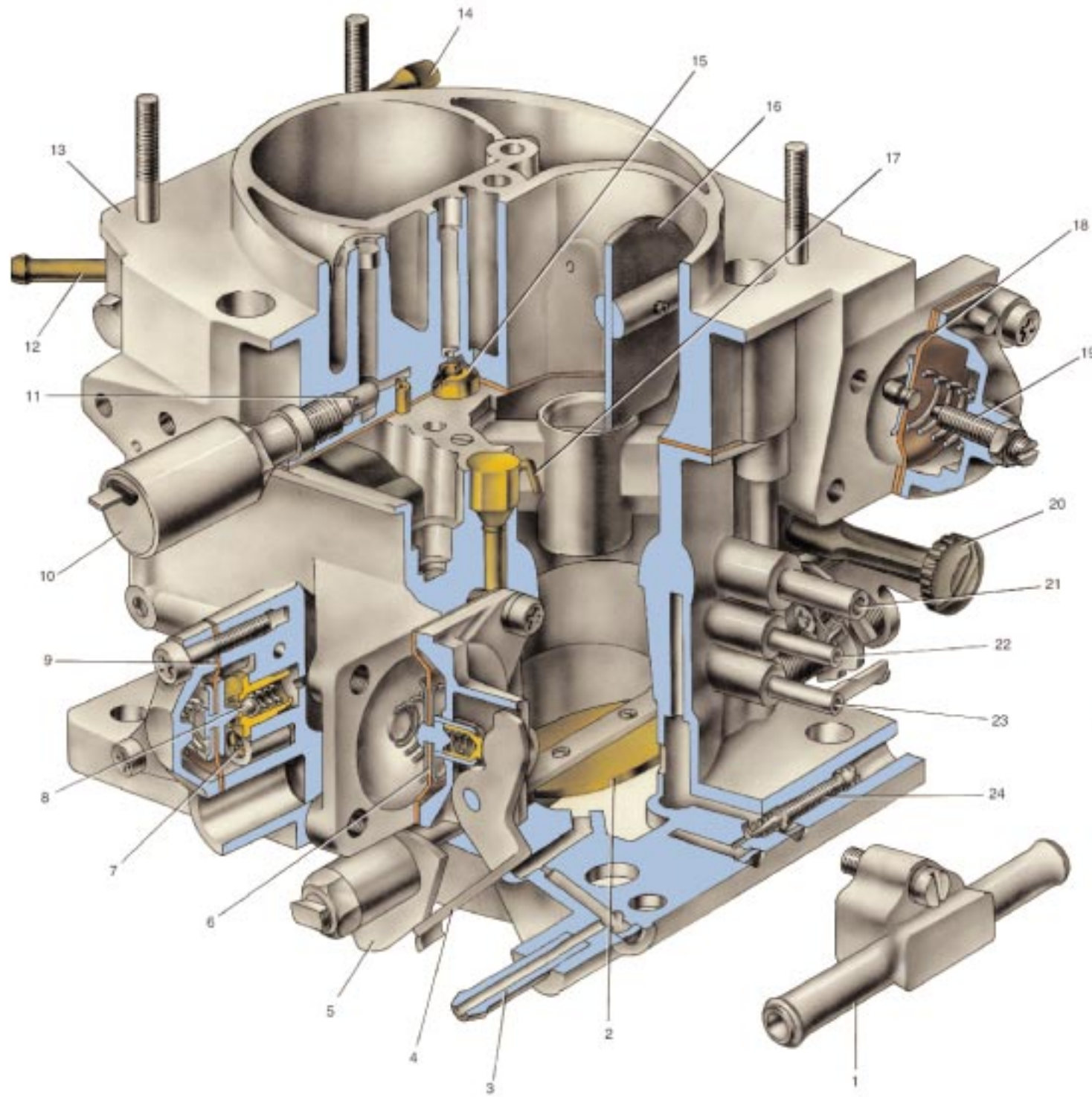

CARBURETTOR

1. Part throttle channel heater
2. Primary throttle
3. Crankcase emission suction union
4. Accelerator pump operating lever
5. Accelerator pump rocker arm
6. Accelerator pump diaphragm
7. Fuel jet, part throttle enrichment
8. Ball valve, part throttle enrichment
9. Diaphragm, part throttle enrichment

10. Electromagnetic shut-off valve
11. Idling fuel jet
12. Return pipe to fuel tank
13. Carburettor cover
14. Supply union
15. Primary barrel main air jet
16. Choke valve plate
17. Accelerator pump atomizers
18. Pull-down diaphragm
19. Adjustment screw
20. Throttle stop screw

- 21.22. Vacuum discharge to EGR system
23. Vacuum discharge to ignition distributor vacuum control
24. Idle mixture adjusting screw
25. Primary throttle adjustment screw (pull-down unit)
26. Choke operating lever
27. Choke drive lever
28. Secondary barrel main air jet
29. Emulsion tube
30. Secondary barrel main fuel atomizer
31. Fuel filter
32. Float chamber needle valve

33. Carburettor body
34. Secondary throttle
35. Secondary throttle lever
36. Secondary barrel main fuel jet
37. Secondary throttle operating lever
38. Float
39. Throttle valves operating lever
40. Secondary barrel lock lever

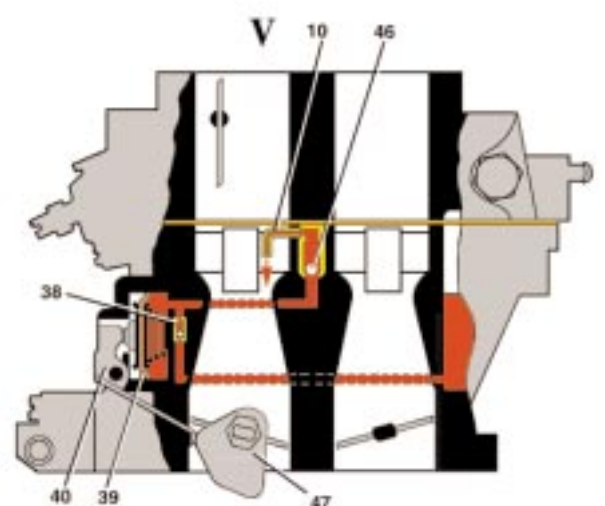
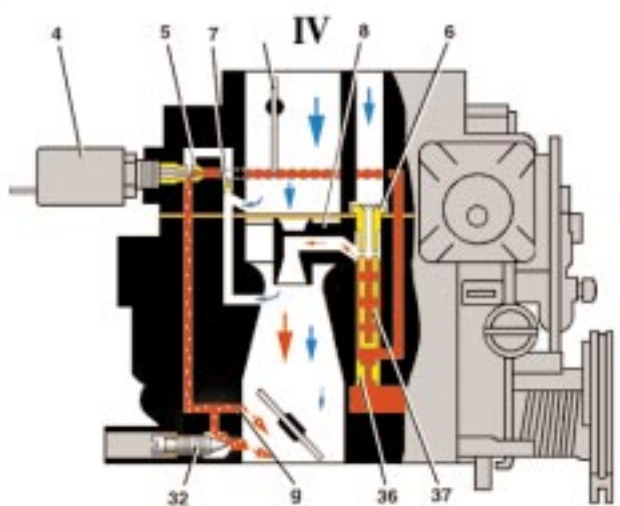
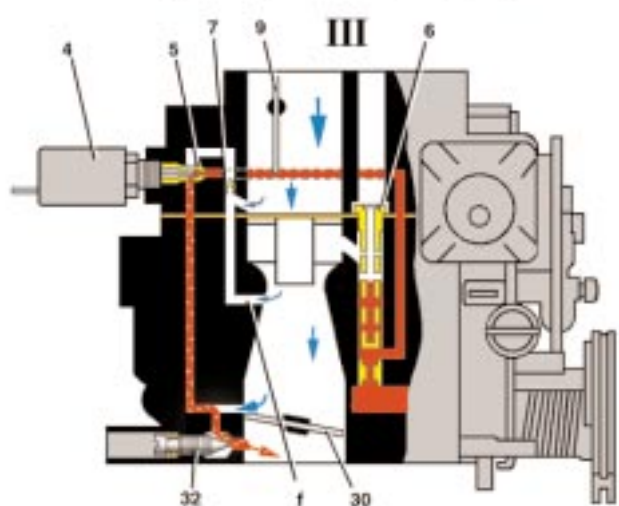
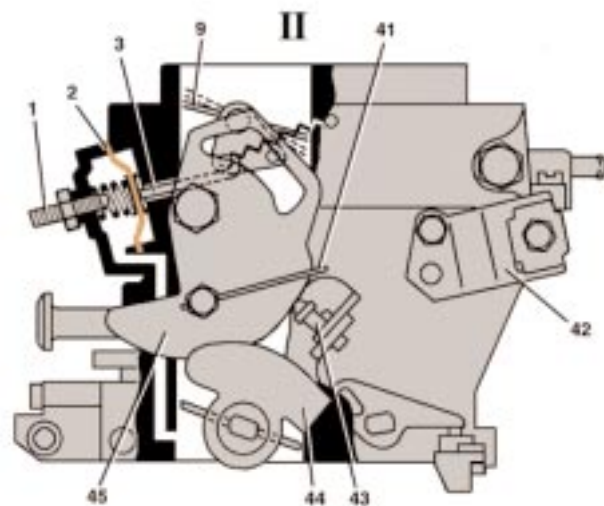
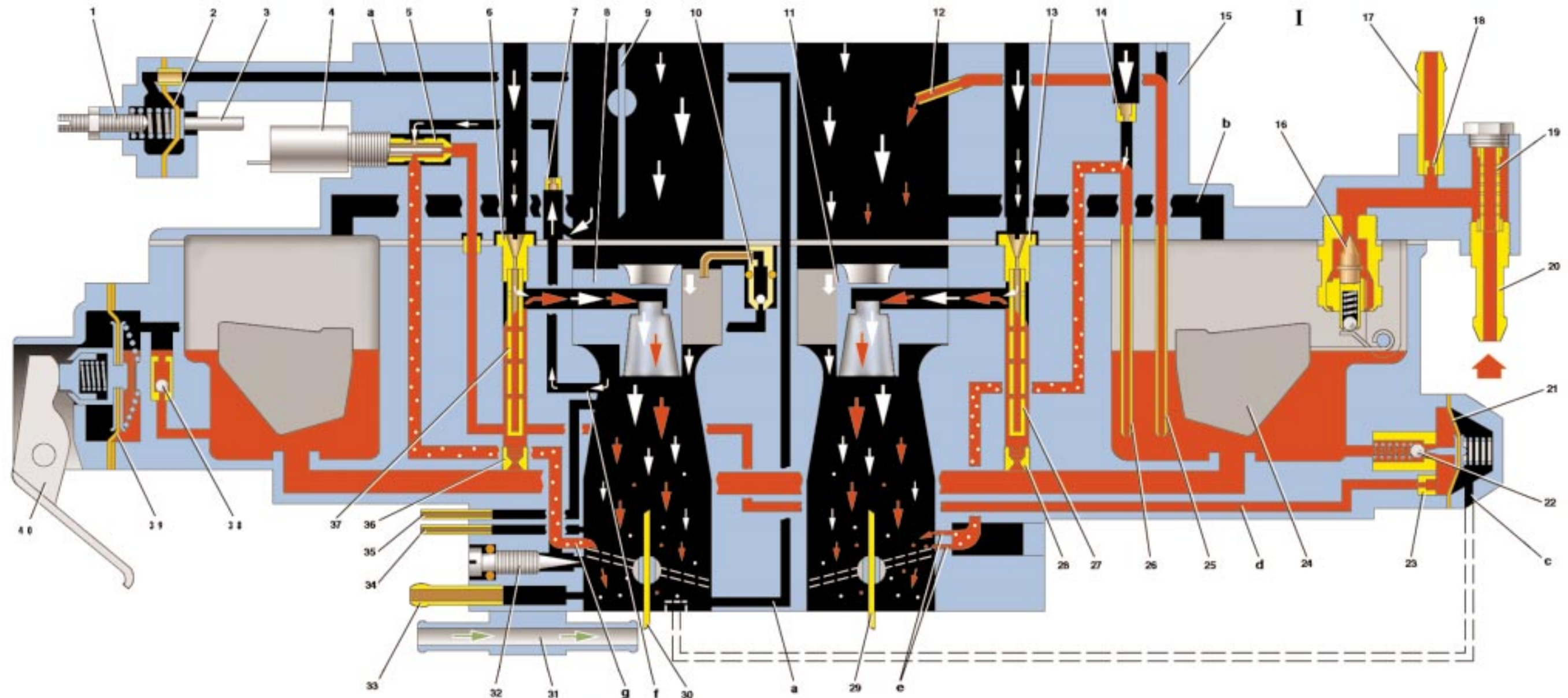

CARBURETTOR OPERATION DIAGRAM

- 1. Adjustment screw (choke pull-down unit)
- 2. Pull-down diaphragm
- 3. Pushrod
- 4. Electromagnetic shut-off valve
- 5. Idling fuel jet
- 6. Main air jet, primary barrel
- 7. Idling air jet
- 8. Main fuel atomizer, primary barrel
- 9. Choke valve plate
- 10. Accelerator pump nozzle
- 11. Main fuel atomizer, secondary barrel

- 12. Injection pipe, full throttle enrichment
- 13. Secondary main air jet
- 14. Air correction jet, secondary barrel
- 15. Carburettor top cover
- 16. Needle valve
- 17. Return line to fuel tank
- 18. Fuel-to-tank return jet
- 19. Fuel filter
- 20. Fuel supply to carburettor
- 21. Diaphragm, part throttle enrichment
- 22. Ball valve, part throttle enrichment
- 23. Fuel jet, part throttle enrichment
- 24. Float

- 25. Fuel jet and tube, full throttle enrichment
- 26. Secondary barrel fuel correction jet with tube
- 27. Secondary barrel emulsion tube
- 28. Secondary barrel main fuel jet
- 29. Secondary throttle
- 30. Primary throttle
- 31. Part throttle channel heater
- 32. Idle mixture adjustment screw
- 33. Crankcase emission discharge pipe
- 34. Vacuum discharge to ignition distributor vacuum control
- 35. Vacuum discharge to EGR valve (second pipe is not shown)

- 36. Primary main fuel jet
- 37. Primary emulsion tube
- 38. Accelerator pump non-return ball valve
- 39. Accelerator pump diaphragm
- 40. Accelerator pump operating lever
- 41. Choke drive lever
- 42. Outer rod securing bracket
- 43. Primary throttle adjusting screw (pull-down unit)
- 44. Throttle valve operating lever
- 45. Choke control lever
- 46. Fuel supply ball valve
- 47. Accelerator pump operating cam

- a. Air passage, pull-down unit
- b. Float chamber balance passage
- c. Air passage, part throttle enrichment
- d. Fuel passage, part throttle enrichment
- e. Secondary correction outlet ports
- f. Idling air passage hole
- g. Idling transients hole

- I. Carburettor operation diagram at full throttle
- II. Pull-down unit operation diagram
- III. Carburettor operation diagram at idle speed
- IV. Carburettor operation diagram at part throttle
- V. Acceleration pump operation diagram

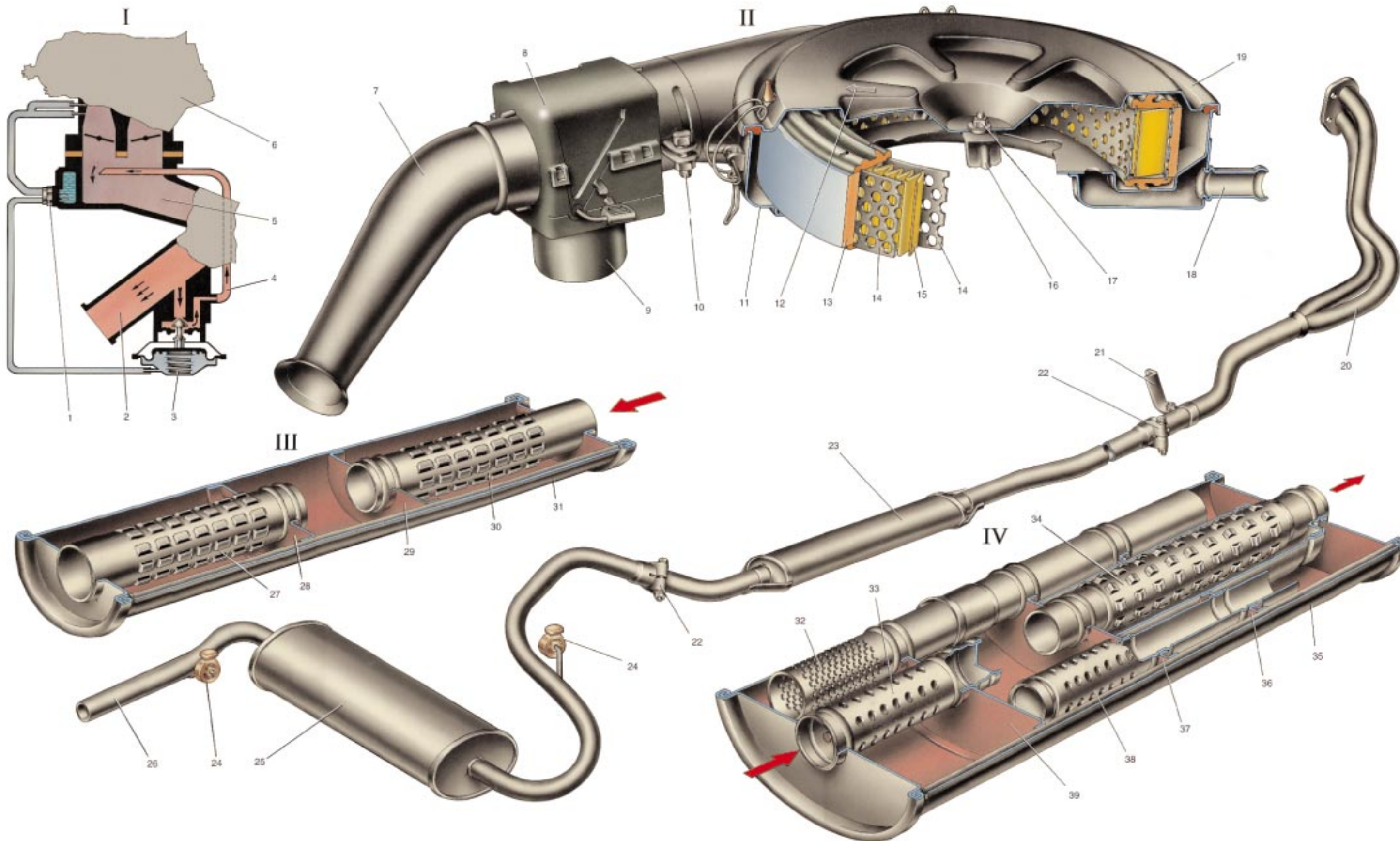

AIR CLEANER. SILENCERS.

- 1. EGR valve thermo-vacuum switch
- 2. Exhaust manifold
- 3. EGR valve
- 4. EGR tube
- 5. Intake manifold
- 6. Carburettor
- 7. Cold air intake

- 8. Temperature flap
- 9. Warm air intake manifold
- 10. Pinch bolt
- 11. Air cleaner housing
- 12. Pointer for air filter cover alignment
- 13. Gauze
- 14. Filter element perforated plates
- 15. Paper filter element
- 16. Air cleaner cover mounting bracket

- 17. Securing nut
- 18. Discharge pipe
- 19. Air cleaner cover
- 20. Front exhaust pipe
- 21. Front exhaust pipe bracket
- 22. Clips
- 23. Intermediate silencer
- 24. Suspension rings
- 25. Main silencer

- 26. Tail pipe
- 27. Intermediate silencer rear perforated tube
- 28. Intermediate silencer rear baffle plate
- 29. Front baffle plate
- 30. Front perforated tube
- 31. Intermediate silencer housing
- 32. Main silencer front perforated tube
- 33. Main silencer inlet pipe
- 34. Main silencer outlet pipe

- 35. Main silencer housing
- 36. Rear baffle plate
- 37. Centre baffle plate
- 38. Rear perforated tube
- 39. Front baffle plate

- I. Recirculation diagram
- II. Air cleaner unit
- III. Intermediate silencer
- IV. Main silencer

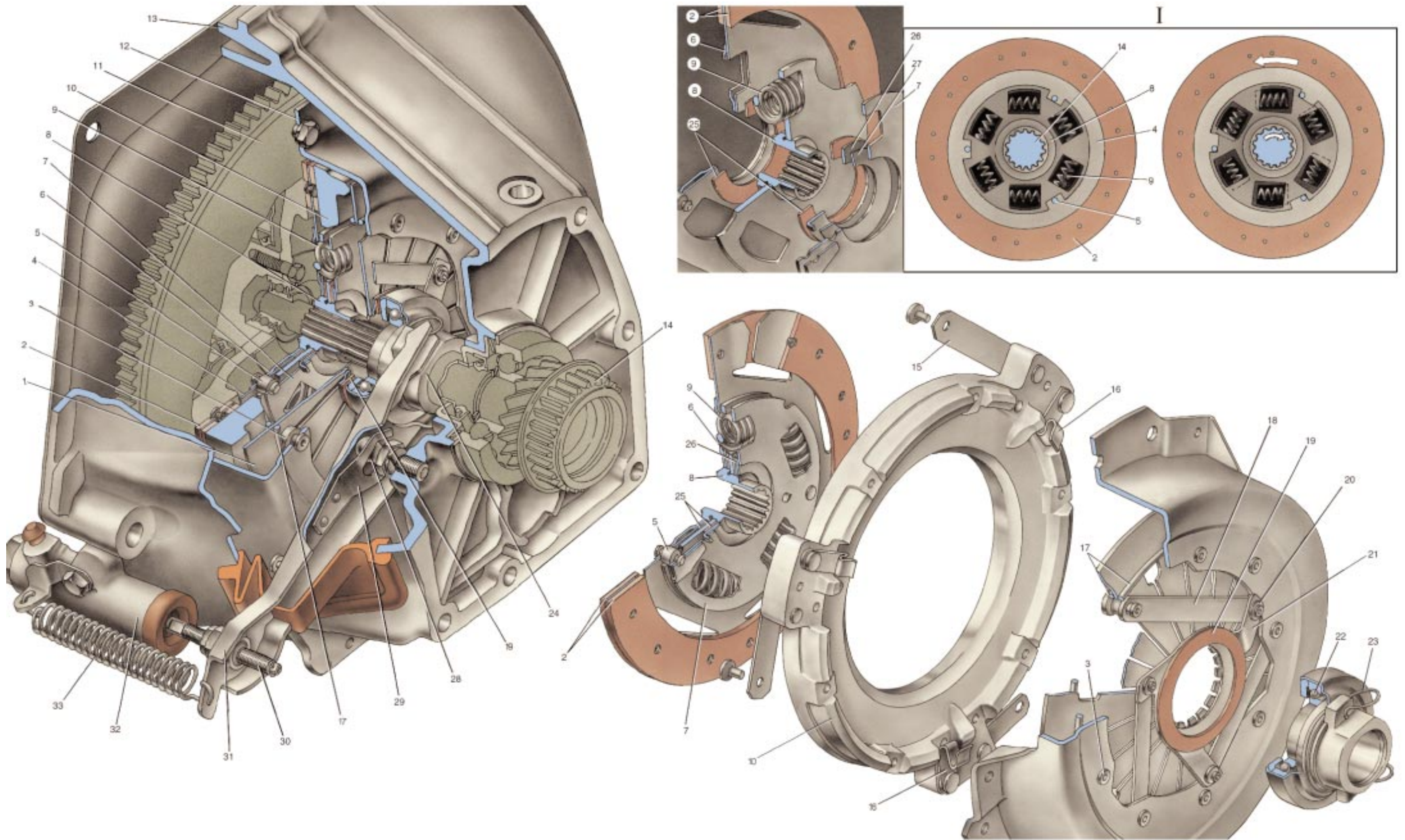

CLUTCH

- 1. Diaphragm spring
- 2. Clutch friction discs
- 3. Diaphragm spring rivet
- 4. Clutch disc
- 5. Rivet - damper tip
- 6. Disc adaptor

- 7. Retainer plate
- 8. Clutch disc hub
- 9. Damper spring
- 10. Pressure plate
- 11. Flywheel
- 12. Clutch cover
- 13. Clutch bellhousing
- 14. Gearbox input shaft

- 15. Pressure plate - to - clutch cover strap
- 16. Diaphragm spring clip
- 17. Diaphragm spring fulcrum ring
- 18. Thrust flange / clutch cover strap
- 19. Thrust flange friction washer
- 20. Strap rivet
- 21. Diaphragm spring thrust flange
- 22. Release bearing

- 23. Clutch release fork / bearing spring
- 24. Clutch release bearing
- 25. Damper friction washer
- 26. Spring washer bearing disc
- 27. Damper spring washer
- 28. Release fork ball pivot
- 29. Release fork spring
- 30. Release fork pushrod

- 31. Clutch release fork
 - 32. Slave cylinder
 - 33. Release fork return spring
- I. Damper operation diagram

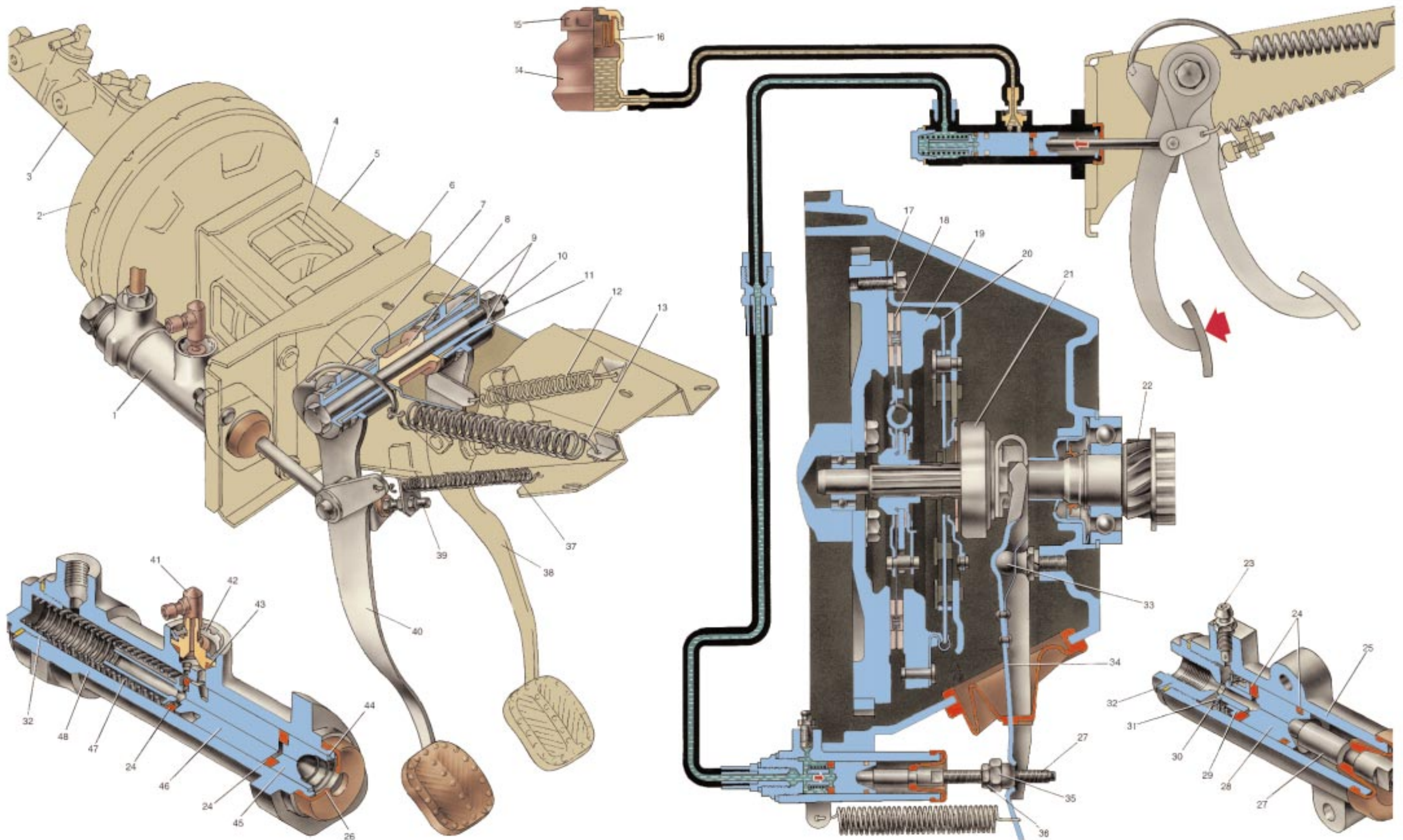

CLUTCH OPERATION SYSTEM

- 1. Clutch master cylinder
- 2. Vacuum servo unit
- 3. Brake master cylinder
- 4. Servo boot
- 5. Vacuum servo bracket
- 6. Pedal cluster mounting bracket
- 7. Over-centre spring hook

- 8. Pedal spacer sleeve
- 9. Pedal outer bushes
- 10. Brake / clutch pedal shaft
- 11. Pedal inner bush
- 12. Brake pedal return spring
- 13. Booster spring
- 14. Master cylinder fluid reservoir
- 15. Filler cap
- 16. Baffle

- 17. Clutch cover
- 18. Clutch disc
- 19. Pressure plate
- 20. Diaphragm spring
- 21. Clutch release bearing
- 22. Gearbox input shaft
- 23. Sealing ring
- 24. Slave cylinder housing

- 26. Protective cap
- 27. Release fork pushrod
- 28. Piston
- 29. Piston bearing plate
- 30. Spring disc
- 31. Circlip
- 32. Plug
- 33. Clutch release fork ball pivot
- 34. Clutch release fork

- 35. Adjustment nut
- 36. Locknut
- 37. Clutch pedal return spring
- 38. Brake pedal
- 39. Clutch pedal screw
- 40. Clutch pedal
- 41. Union
- 42. Retaining washer
- 43. Gasket

- 44. Circlip
- 45. Pushrod piston
- 46. Master cylinder piston
- 47. Return spring
- 48. Master cylinder body

I. Clutch hydraulic system operation diagram

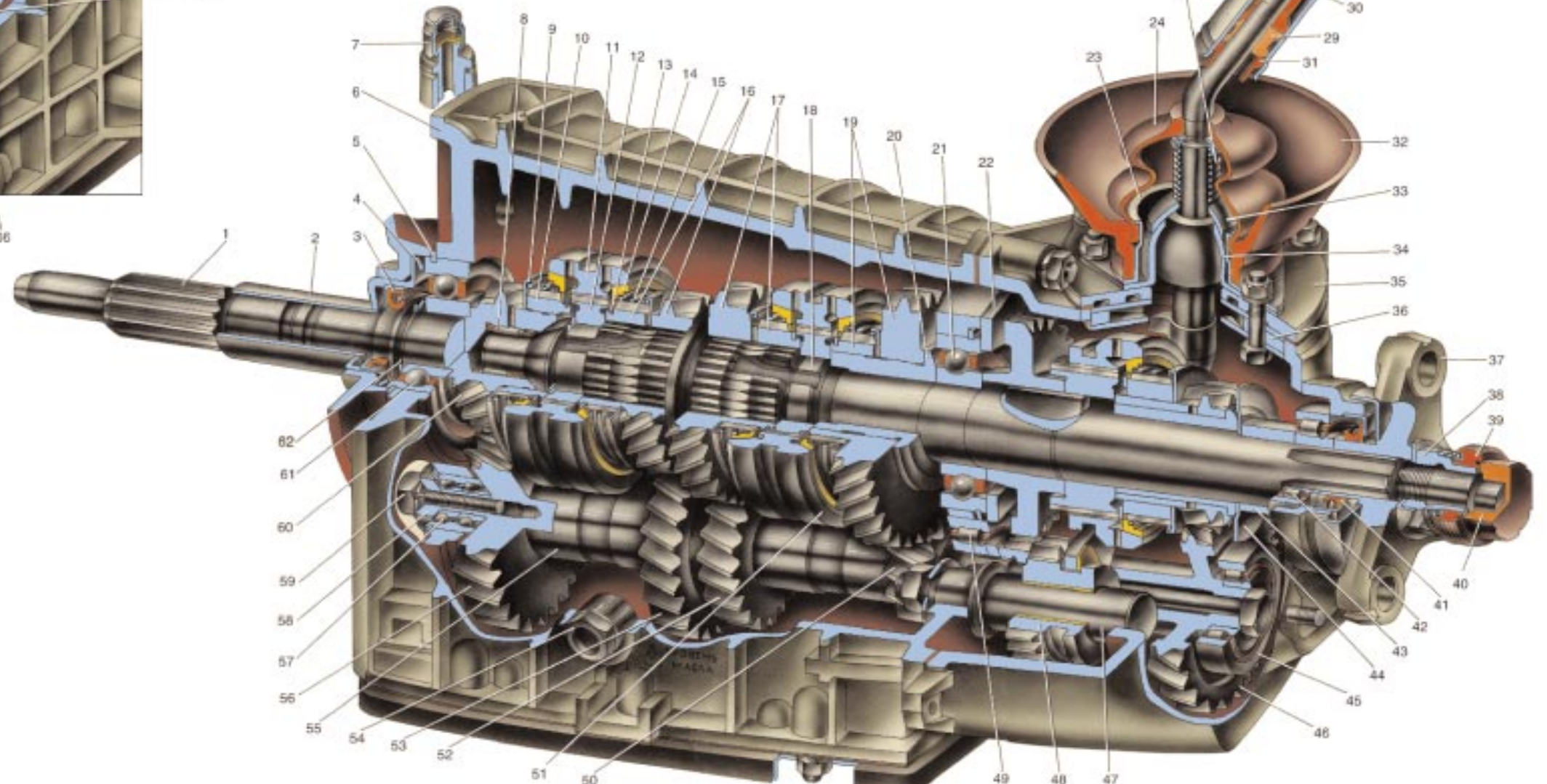
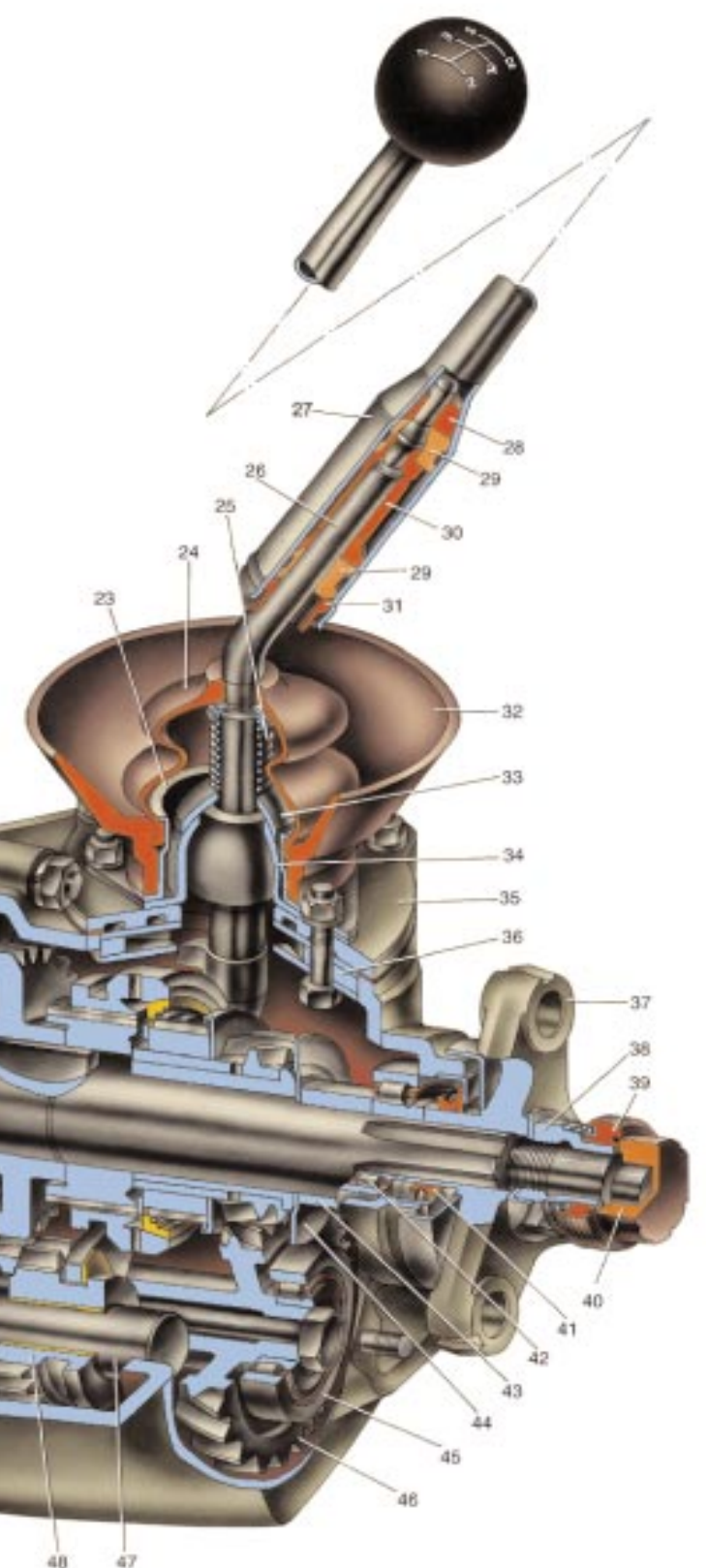
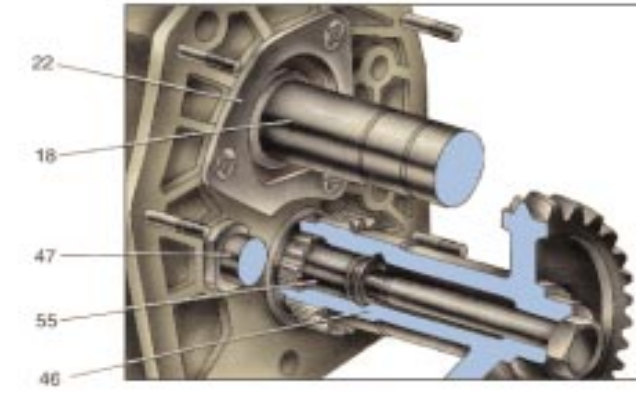
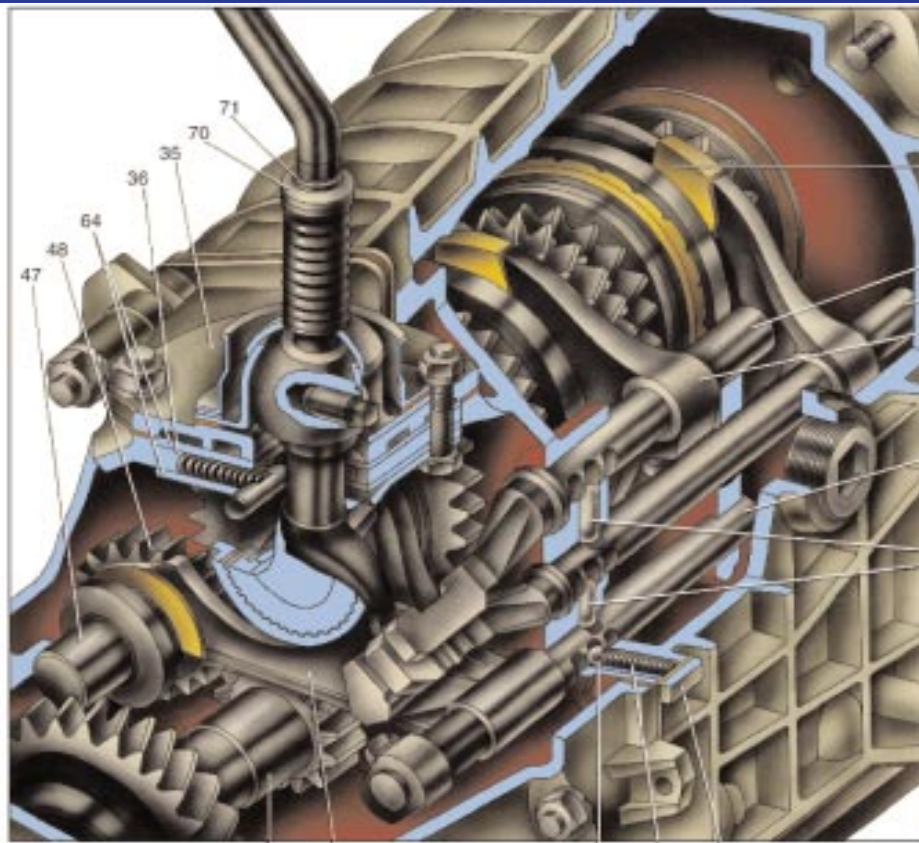

GEARBOX

- 1. Input shaft
- 2. Gearbox front cover with clutch release bearing guide sleeve
- 3. Input shaft oil seal
- 4. Spring washer
- 5. Bearing thrust ring
- 6. Gearbox housing
- 7. Breather
- 8. Output shaft needle bearing
- 9. Synchro sleeve thrust washer
- 10. 4th speed synchro unit crown
- 11. 3rd / 4th synchro unit sleeve
- 12. 3rd / 4th synchro unit hub
- 13. Circlip
- 14. Synchro - ring
- 15. Spring
- 16. 3rd speed synchro gear
- 17. 2nd speed synchro gear
- 18. Output shaft
- 19. 1st speed synchro gear
- 20. 1st gear bush
- 21. Output shaft idler bearing
- 22. Lock plate
- 23. Flange
- 24. Bellows
- 25. Spring
- 26. Gear change lever
- 27. Lever rod
- 28. Thrust ring
- 29. Rubber ring
- 30. Spacer
- 31. Retaining sleeve
- 32. Collar
- 33. Cap
- 34. Ball socket
- 35. Gear change lever housing
- 36. Guide plate
- 37. Propeller shaft coupling flange
- 38. Nut
- 39. Centering ring seal
- 40. Centering ring
- 41. Output shaft rear bearing oil seal
- 42. Output shaft rear bearing
- 43. Spacer sleeve
- 44. Oil deflector washer
- 45. Gear unit bearing
- 46. 5th speed / reverse gear unit
- 47. Reverse idler gear shaft
- 48. Reverse idler gear
- 49. Intermediate shaft rear bearing
- 50. Intermediate shaft 1st speed gear
- 51. 1st/2nd synchro sleeve
- 52. Intermediate shaft 2nd speed gear
- 53. Intermediate shaft 3rd speed gear
- 54. Filler and check orifice cap
- 55. Intermediate shaft
- 56. Intermediate shaft constant mesh gear
- 57. Intermediate shaft front bearing
- 58. Intermediate shaft bearing clamping washer
- 59. Clamping washer bolt
- 60. Input shaft constant mesh gear
- 61. Input shaft rear bearing
- 62. Circlip
- 63. Reverse lock clip
- 64. Guide plate washers
- 65. Guide bar
- 66. Detents cover
- 67. Spring
- 68. Detent
- 69. 5th / reverse shift fork
- 70. Thrust washer
- 71. Circlip
- 72. 3rd / 4th selector fork
- 73. 1st / 2nd selector rod
- 74. 3rd / 4th selector rod
- 75. 1st / 2nd selector fork
- 76. 5th / reverse selector rod
- 77. Locking collets

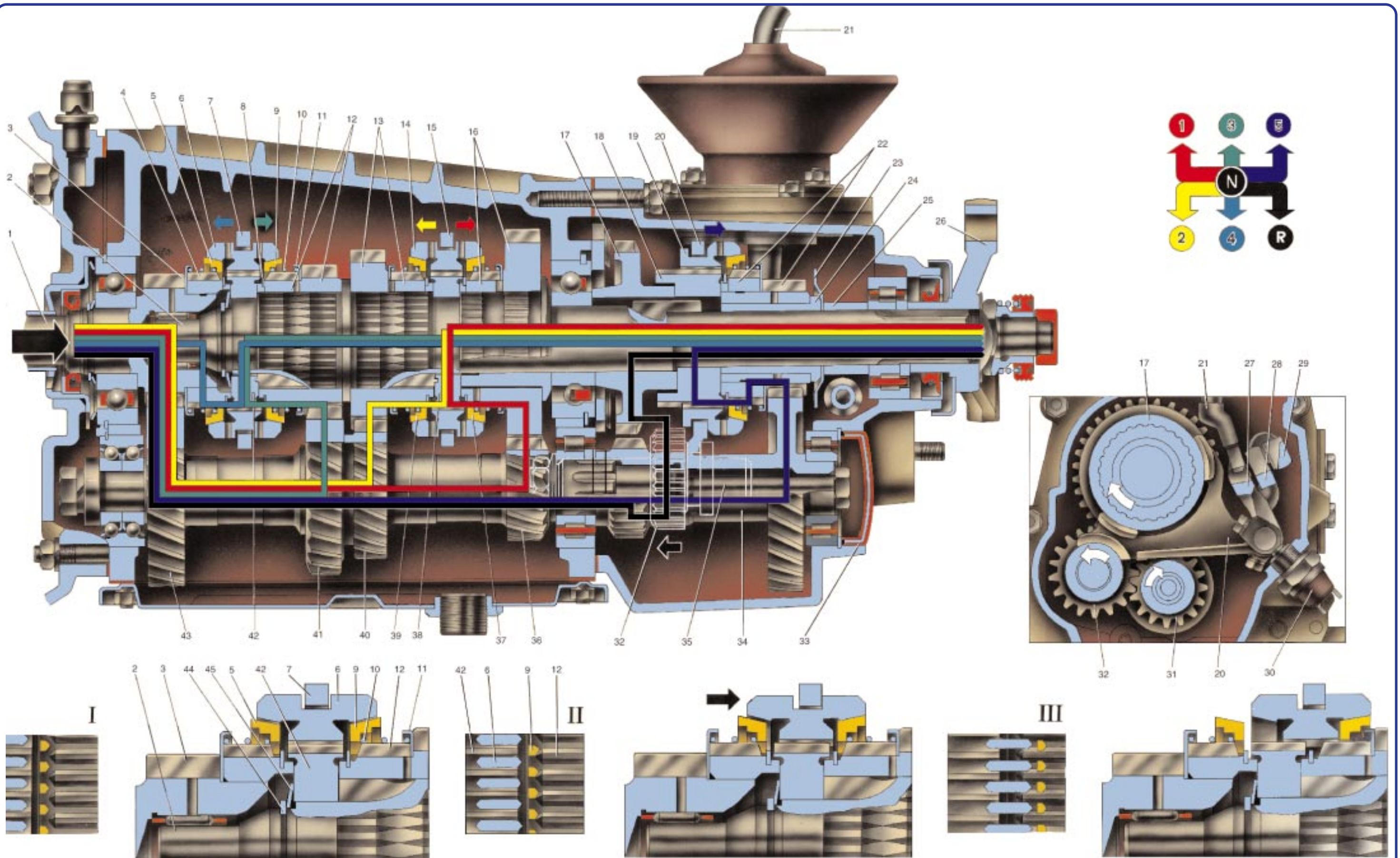

GEARBOX OPERATION DIAGRAM

- 1. Input shaft
- 2. Output shaft
- 3. Input shaft constant mesh gear
- 4. 4th speed synchro crown
- 5. 4th gear synchro baulk ring
- 6. 3rd and 4th synchro sleeve
- 7. 3rd and 4th gear selector fork
- 8. Synchro circlip

- 9. 3rd synchro baulk ring
- 10. Synchro spring
- 11. Synchro spring thrust washer
- 12. 3rd synchro gear and crown
- 13. 2nd synchro gear and crown
- 14. 1st and 2nd synchro sleeve
- 15. 1st and 2nd gear selector fork
- 16. 1st synchro gear and crown
- 17. Reverse gear
- 18. 5th synchro sleeve hub

- 19. 5th synchro sleeve
- 20. 5th and reverse gear selector fork
- 21. Gear change lever
- 22. 5th synchro gear and crown
- 23. Oil deflector washer
- 24. 5th gear bush
- 25. Distance sleeve
- 26. Flexible sleeve flange
- 27. 5th gear and reverse selector rod
- 28. 3rd and 4th selector rod

- 29. 1st and 2nd selector fork rod
- 30. Reverse light switch
- 31. Gear unit reverse gear
- 32. Reverse idler gear
- 33. End plug
- 34. 5th and reverse gear unit
- 35. Reverse idler gear shaft
- 36. Layshaft 1st speed gear
- 37. 1st synchro baulk ring
- 38. 1st and 2nd synchro sleeve hub

- 39. 2nd synchro baulk ring
- 40. Layshaft 2nd speed gear
- 41. Layshaft 3rd speed gear
- 42. 3rd and 4th synchro sleeve hub
- 43. Layshaft constant mesh gear
- 44. Circlip
- 45. Poppet spring

- I. Neutral position
- II. Beginning of 3rd gear engagement
- III. Complete engagement of 3rd gear

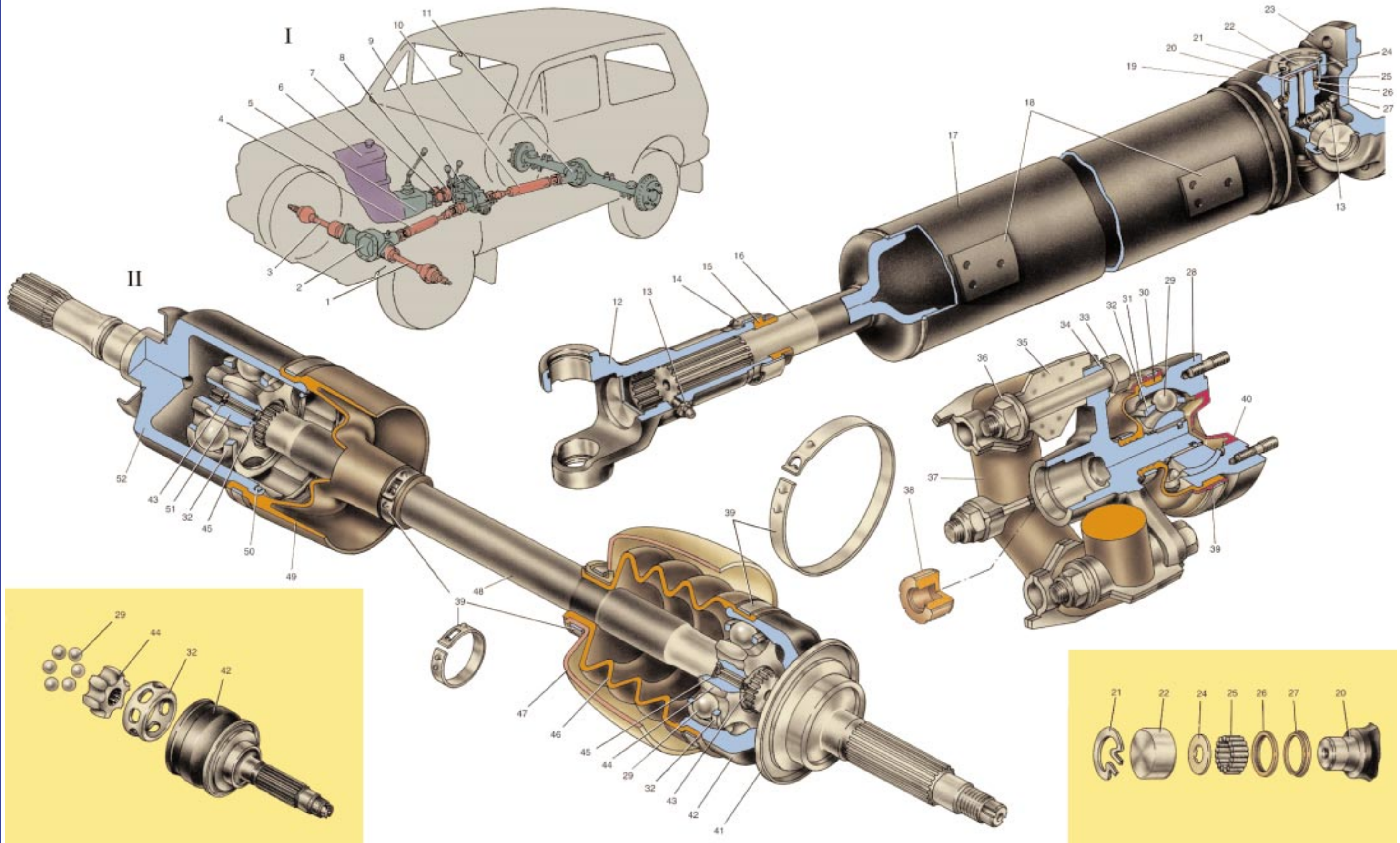

PROPELLER SHAFT

- 1. LH wheel drive
- 2. Front axle
- 3. RH wheel drive
- 4. Forward propeller shaft
- 5. Gearbox
- 6. Engine
- 7. Layshaft flexible coupling

- 8. Layshaft constant velocity joint
- 9. Torque converter
- 10. Rear propeller shaft
- 11. Rear axle
- 12. Sliding yoke
- 13. Oiler
- 14. Retainer
- 15. Grease seal
- 16. Propeller shaft end

- 17. Propeller shaft tube
- 18. Balance plate
- 19. Propeller shaft joint fork
- 20. Propeller shaft trunnion
- 21. Needle bearing circlip
- 22. Needle roller housing
- 23. Flange - propeller shaft yoke
- 24. Washer
- 25. Needle roller

- 26. Needle bearing oil seal
- 27. Trunnion oil seal
- 28. Constant velocity joint shell
- 29. Ball
- 30. Boot
- 31. Protective shroud
- 32. Cage
- 33. Coupling flange securing bolt
- 34. Coupling flange

- 35. Coupling liner
- 36. Balance washer
- 37. Rubber sleeve
- 38. Centering bush
- 39. Clips
- 40. Plug
- 41. Oil seal splash guard ring
- 42. Outer joint shell
- 43. Circlip

- 44. Outer joint race
- 45. Thrust ring
- 46. Outer joint boot
- 47. Protective sleeve
- 48. Road wheel drive shaft
- 49. Inner joint boot
- 50. Detent
- 51. Inner joint race
- 52. Inner joint shell

- I. Drive line view
- II. Front wheel drive

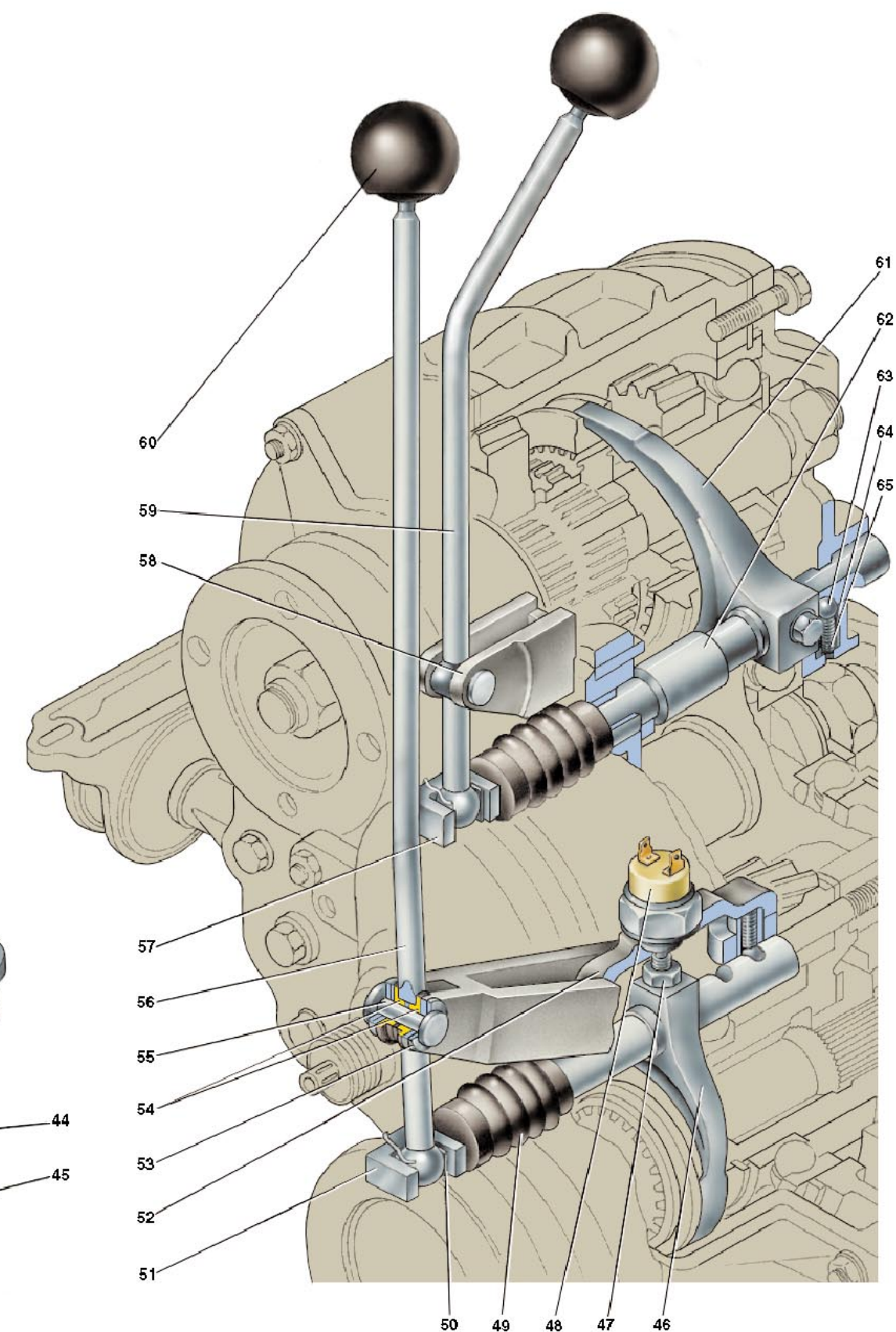
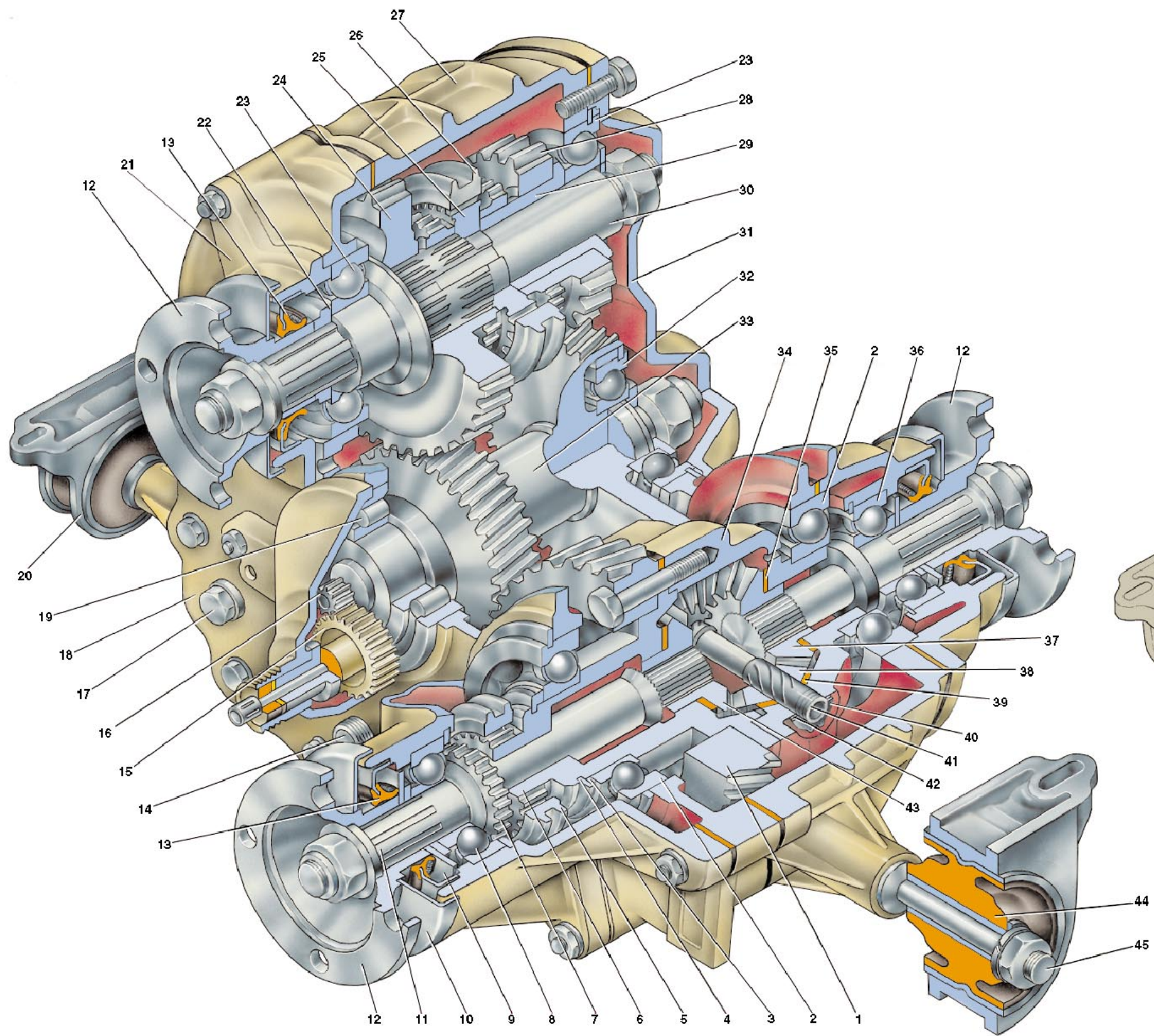

TORQUE CONVERTER AND ITS DRIVE SYSTEM

- 1. Driven gear
- 2. Differential bearings
- 3. Spring washer
- 4. Circlip
- 5. Differential locking coupling
- 6. Differential carrier crown
- 7. Front axle drive shaft crown
- 8. Front axle drive shaft bearing
- 9. Oil slinger

- 10. Splash guard
- 11. Front axle drive shaft
- 12. Flange
- 13. Oil seal
- 14. Oil drain plug
- 15. Speedometer driven gear
- 16. Speedometer drive gear
- 17. Plug, oil level inspection / top-up orifice
- 18. Torque converter front cover
- 19. Layshaft roller bearing
- 20. Bracket, torque converter mount
- 21. Input shaft bearing cover

- 22. Bearing thrust ring
- 23. Input shaft bearings
- 24. Top gear
- 25. Gear shift clutch hub
- 26. Gear shift clutch
- 27. Torque converter casing
- 28. Low gear
- 29. Low gear bush
- 30. Input shaft
- 31. Rear cover
- 32. Layshaft ball bearing
- 33. Layshaft

- 34. Differential housing
- 35. Rear axle differential gear thrust washer
- 36. Rear axle drive shaft bearing
- 37. Rear axle differential gear
- 38. Pinion
- 39. Pinion thrust washer
- 40. Circlip
- 41. Pinion shaft
- 42. Spring washer
- 43. Front axle differential gear
- 44. Suspension mounting bracket rubber
- 45. Shaft, torque converter mount

- 46. Differential locking clutch yoke
- 47. Yoke stop bolt
- 48. Locked differential warning light switch
- 49. Boot
- 50. Spring
- 51. Differential locking fork rod
- 52. Front axle case cover
- 53. Lock washer
- 54. Lever shaft bush
- 55. Lever shaft
- 56. Differential locking lever
- 57. Gear shift fork rod

- 58. Gear lever bracket
- 59. Gear lever
- 60. Gear lever knob
- 61. Gear shift clutch fork
- 62. Spacer sleeve
- 63. Detent ball
- 64. Detent spring bush
- 65. Detent spring

I. Torque converter operating system

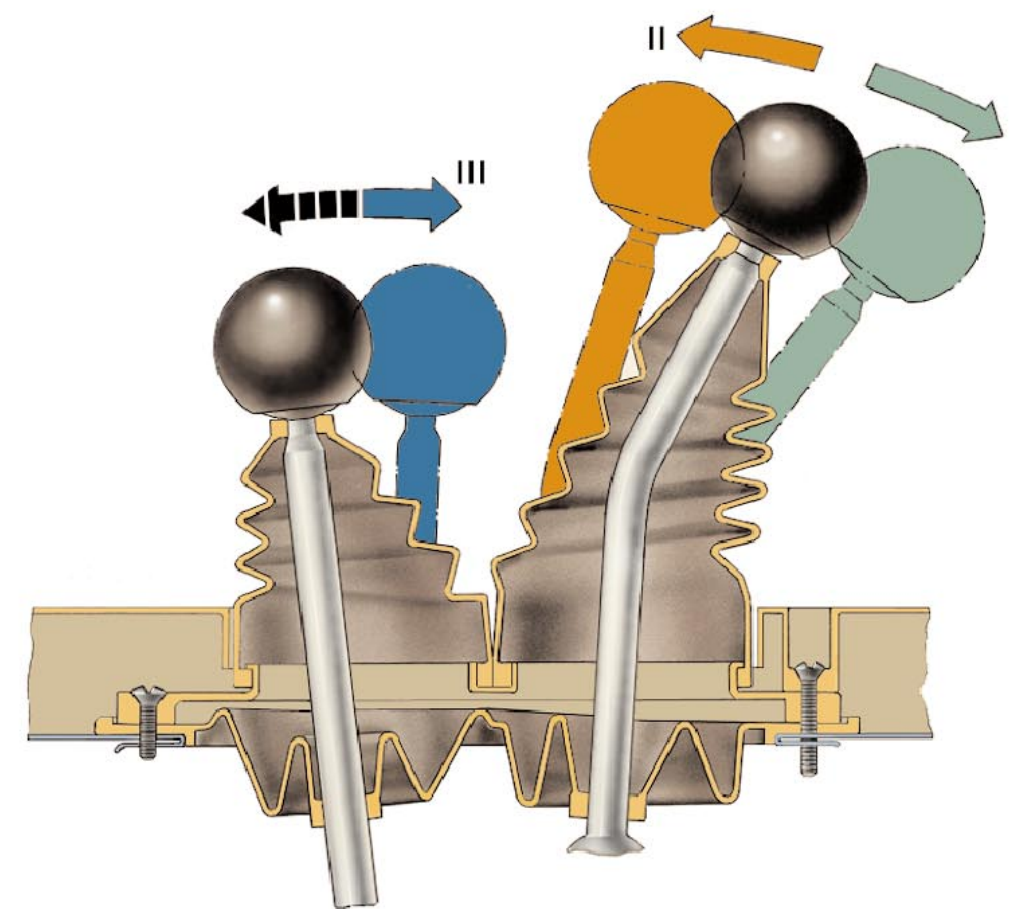
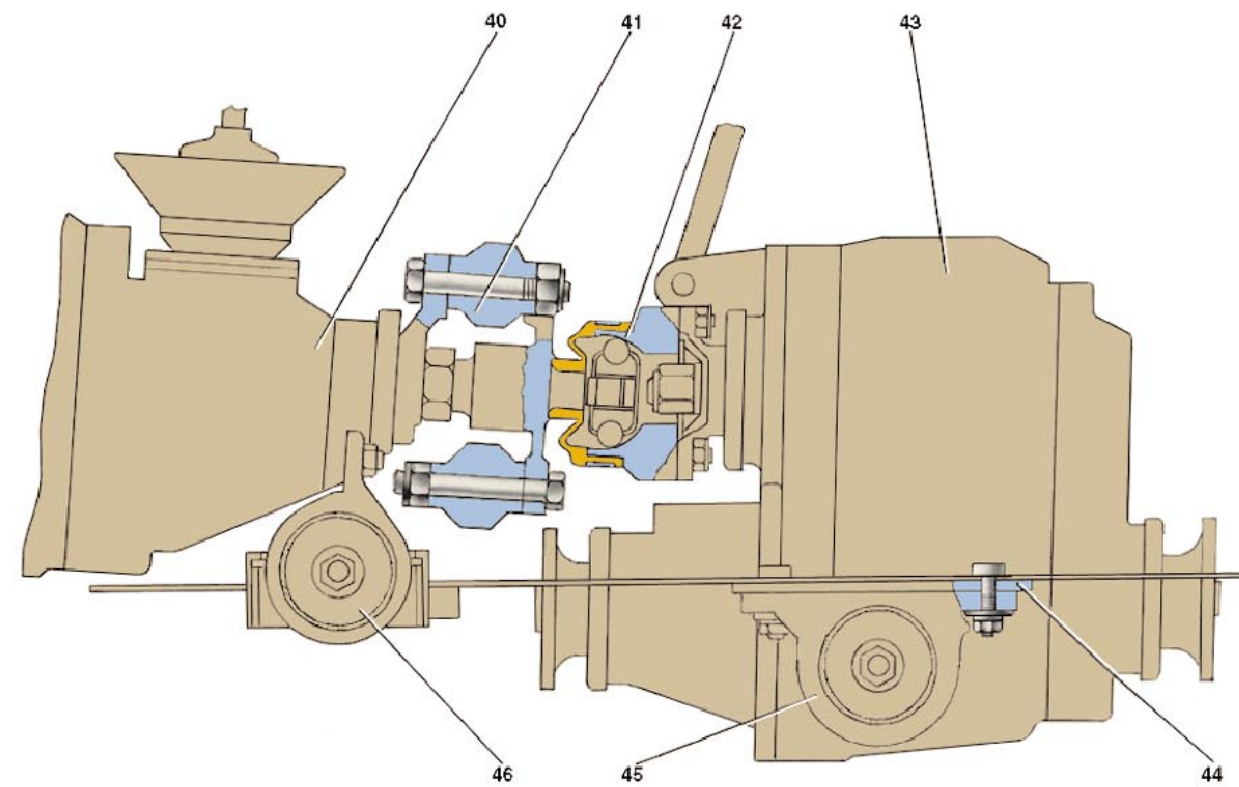
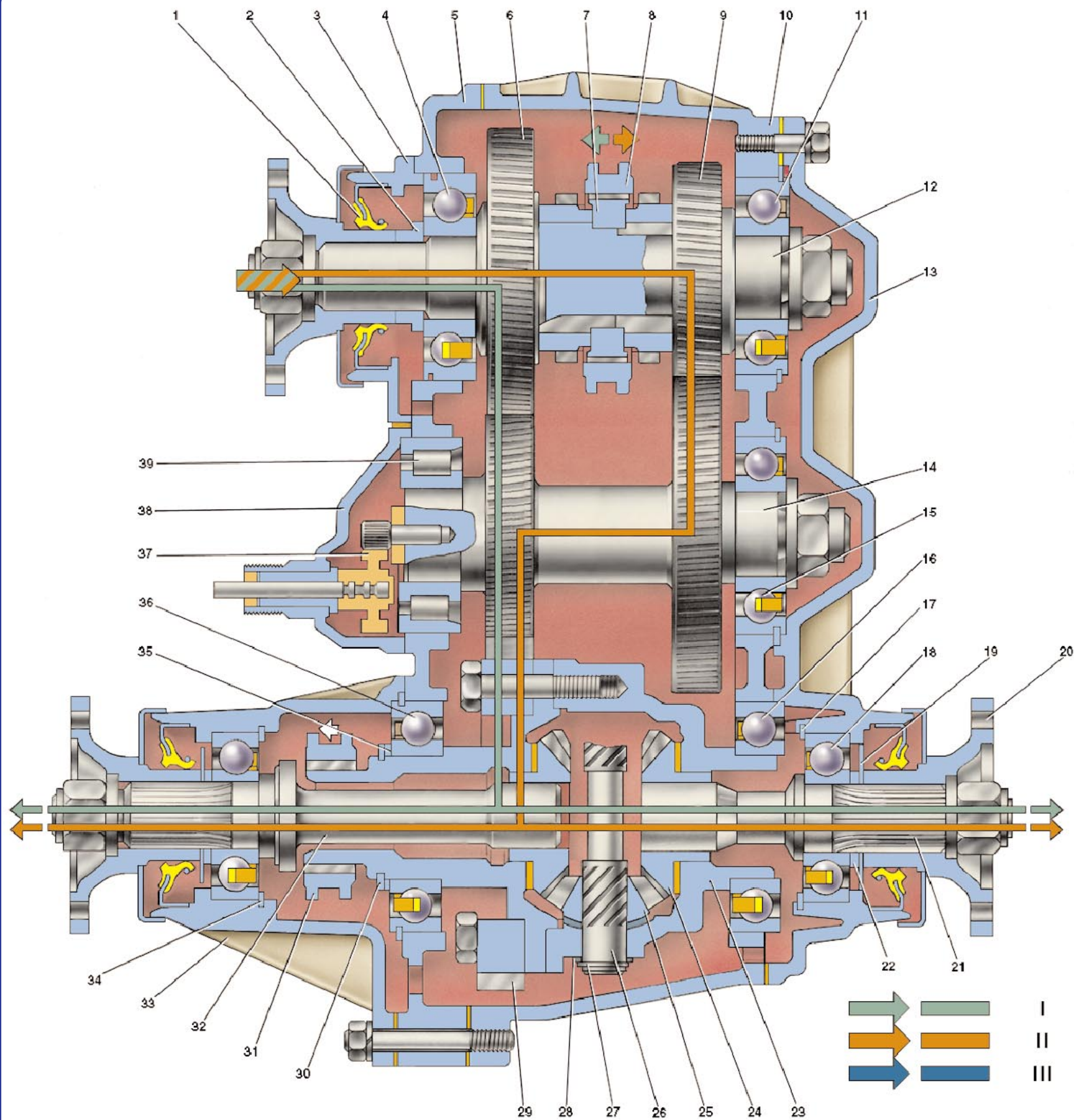

TORQUE CONVERTER OPERATION DIAGRAM

- 1. Grease seal
- 2. Thrust ring, input shaft front bearing
- 3. Front bearing cover
- 4. Input shaft front bearing
- 5. Torque converter front cover
- 6. Top gear
- 7. Gear engagement clutch hub
- 8. Gear engagement clutch

- 9. Low gear
- 10. Torque converter case
- 11. Input shaft rear bearing
- 12. Input shaft
- 13. Torque converter rear cover
- 14. Layshaft
- 15. Layshaft rear bearing
- 16. Differential rear bearing
- 17. Rear axle drive shaft retaining ring
- 18. Rear axle drive shaft bearing
- 19. Oil slinger
- 20. Rear axle drive shaft flange

- 21. Rear axle drive shaft
- 22. Bearing thrust ring
- 23. Differential housing
- 24. Rear axle drive gear
- 25. Pinion
- 26. Differential pinion shaft
- 27. Differential pinion shaft circlip
- 28. Spring washer
- 29. Driven gear
- 30. Differential front bearing circlip
- 31. Differential lock coupling
- 32. Front axle drive shaft

- 33. Front axle casing
- 34. Circlip, front axle drive shaft bearing
- 35. Differential front bearing spring washer
- 36. Differential front bearing
- 37. Speedometer driven gear
- 38. Speedometer drive unit housing
- 39. Layshaft front bearing
- 40. Gearbox
- 41. Coupling
- 42. CV joint
- 43. Torque converter
- 44. Shims

- 45. Bracket, torque converter mounting
- 46. Bracket, engine rear mounting

- I. Top gear engaged
- II. Low gear engaged
- III. Low gear engaged, differential locked up

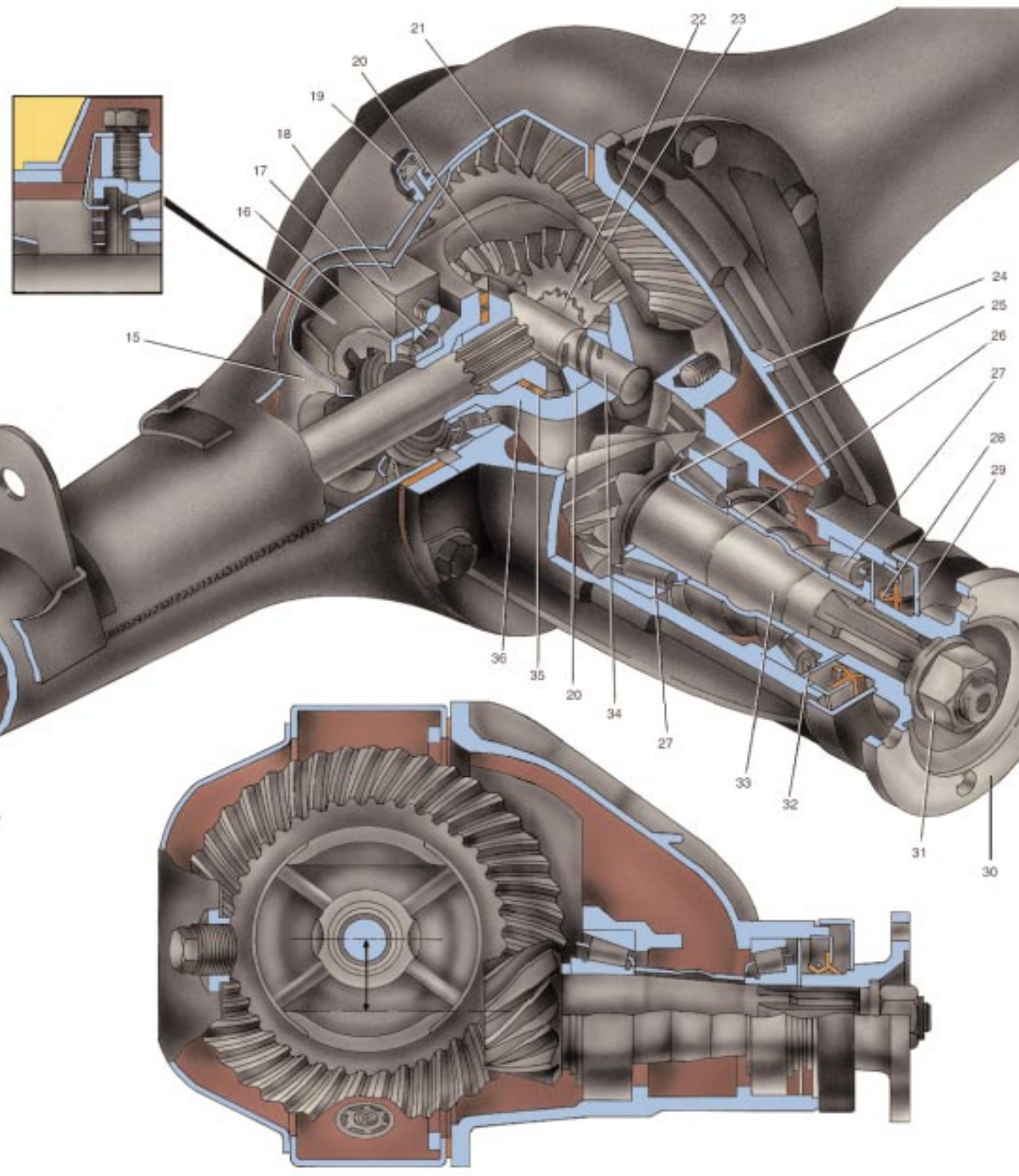
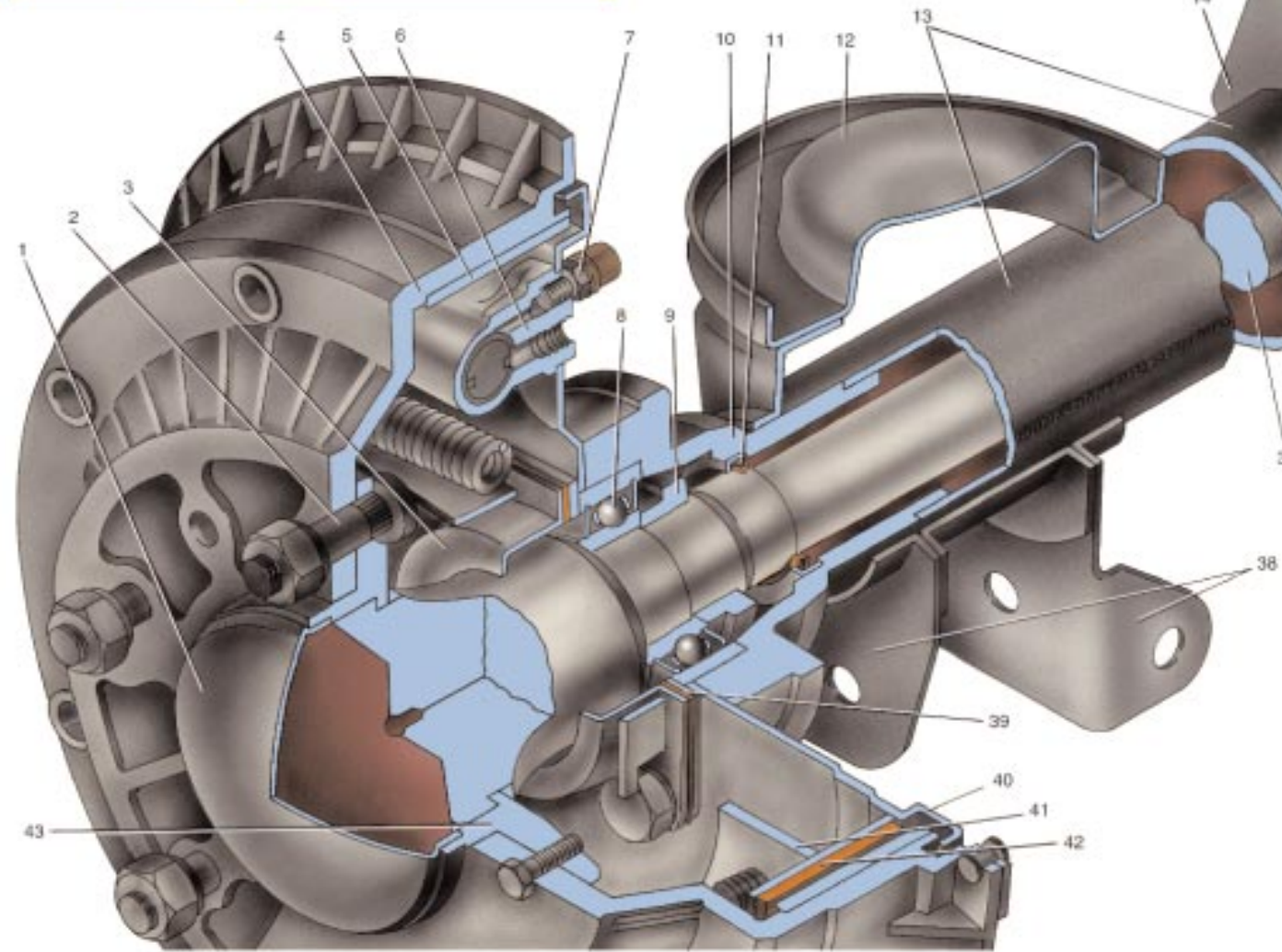
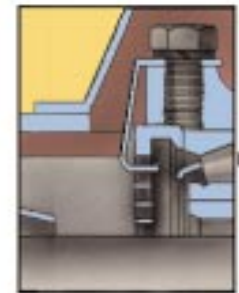
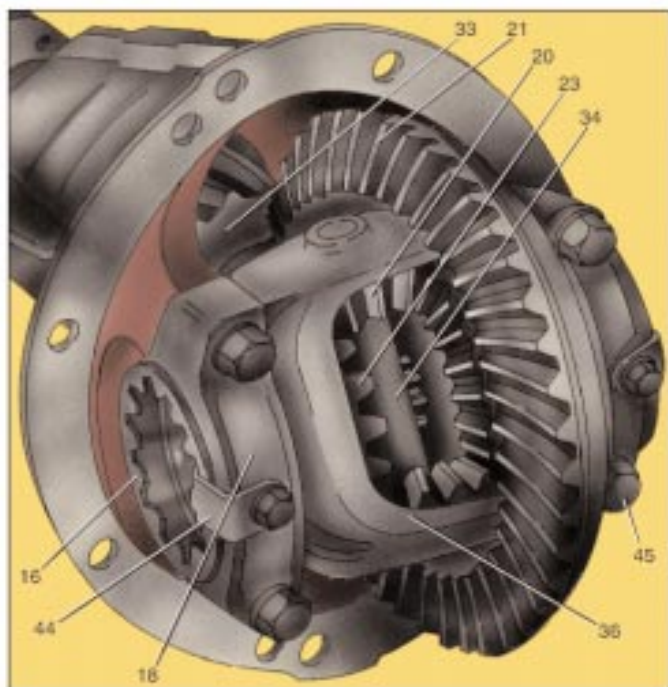

REAR AXLE

- | | | | | |
|--------------------------------------------------------------------------------------------------------------------------------------------------------------------------------------------------------------------------------------------------------------------------------------------------|-----------------------------------------------------------------------------------------------------------------------------------------------------------------------------------------------------------------------------------------------------------------------------------------------------------------------------------------------------------------------------------------------------|-------------------------------------------------------------------------------------------------------------------------------------------------------------------------------------------------------------------------------------------------------------------------------------------------------------------------------------------|----------------------------------------------------------------------------------------------------------------------------------------------------------------------------------------------------------------------------------------------------------------------------------------------------------------------------------------------------------------------------------------------------|---------------------------------------------------------------------------------------------------------------------------------------------------------------------------------------------------------------------------------------------------------------------------------------------|
| <ul style="list-style-type: none"> 1. Road wheel cap 2. Brake drum - to - wheel securing bolt 3. Oil deflector 4. Brake drum 5. Brake drum iron ring 6. Wheel cylinder 7. Brake bleed nipple 8. Half-shaft bearing | <ul style="list-style-type: none"> 9. Bearing locking collar 10. Rear axle beam flange 11. Half-shaft oil seal 12. Coil spring cup 13. Rear axle beam 14. Suspension bar securing bracket 15. Half-shaft guide 16. Differential bearing nut 17. Differential bearing 18. Differential bearing cover | <ul style="list-style-type: none"> 19. Breather 20. Pinion 21. Crown wheel 22. LH halfshaft 23. Halfshaft gear 24. Rear axle reduction gear casing 25. Drive gear shim 26. Bearing spacer sleeve 27. Bearing, pinion 28. Oil seal, pinion | <ul style="list-style-type: none"> 29. Oil seal splash guard 30. Propeller shaft securing flange 31. Nut 32. Oil baffle 33. Pinion, final drive 34. Differential pinion shaft 35. Half-shaft gear thrust washer 36. Differential case 37. RH halfshaft 38. Bracket to secure suspension components | <ul style="list-style-type: none"> 39. Thrust plate, half-shaft bearing 40. Rear brake backplate 41. Rear brake shoe 42. Friction disc 43. Half-shaft flange 44. Bearing nut lockplate 45. Bearing cover securing bolt |
|--------------------------------------------------------------------------------------------------------------------------------------------------------------------------------------------------------------------------------------------------------------------------------------------------|-----------------------------------------------------------------------------------------------------------------------------------------------------------------------------------------------------------------------------------------------------------------------------------------------------------------------------------------------------------------------------------------------------|-------------------------------------------------------------------------------------------------------------------------------------------------------------------------------------------------------------------------------------------------------------------------------------------------------------------------------------------|----------------------------------------------------------------------------------------------------------------------------------------------------------------------------------------------------------------------------------------------------------------------------------------------------------------------------------------------------------------------------------------------------|---------------------------------------------------------------------------------------------------------------------------------------------------------------------------------------------------------------------------------------------------------------------------------------------|

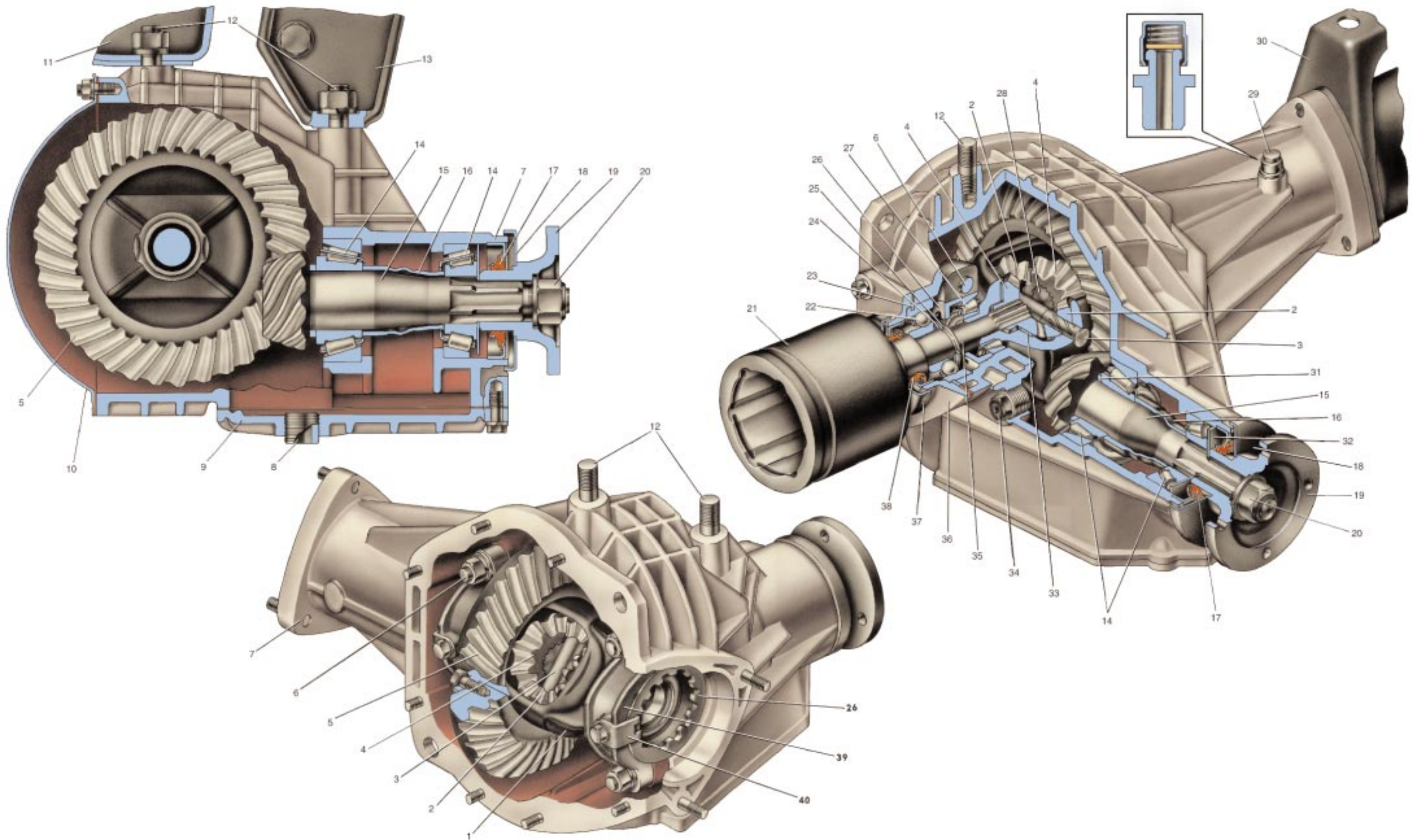

FRONT AXLE

- 1. Differential case
- 2. Differential pinion
- 3. Differential pinion shaft
- 4. Half-shaft gear
- 5. Crown wheel
- 6. Bearing cover retaining stud
- 7. Front axle casing

- 8. Drain plug
- 9. Casing lower cover
- 10. Casing cover
- 11. Bracket, engine front mounting
- 12. Front axle securing stud
- 13. Front axle securing bracket, LH
- 14. Pinion bearings
- 15. Pinion, final drive
- 16. Spacer sleeve
- 17. Pinion oil seal

- 18. Oil seal splash guard
- 19. Pinion flange
- 20. Flange securing nut
- 21. Road wheel drive inner joint
- 22. Inner joint bearing
- 23. Bearing locating ring
- 24. Spring washer
- 25. Circlip
- 26. Differential bearing adjuster nut
- 27. Differential bearing

- 28. Inner joint shell, RH halfshaft
- 29. Breather
- 30. RH bracket, front axle
- 31. Drive gear shim
- 32. Bearing oil deflector
- 33. Half-shaft gear thrust washer
- 34. Filler plug
- 35. LH half-shaft, inner joint shell
- 36. Inner joint shell bearing cover
- 37. Splash guard, joint shell oil seal

- 38. Oil seal
- 39. Differential bearing cover
- 40. Adjuster nut lockplate

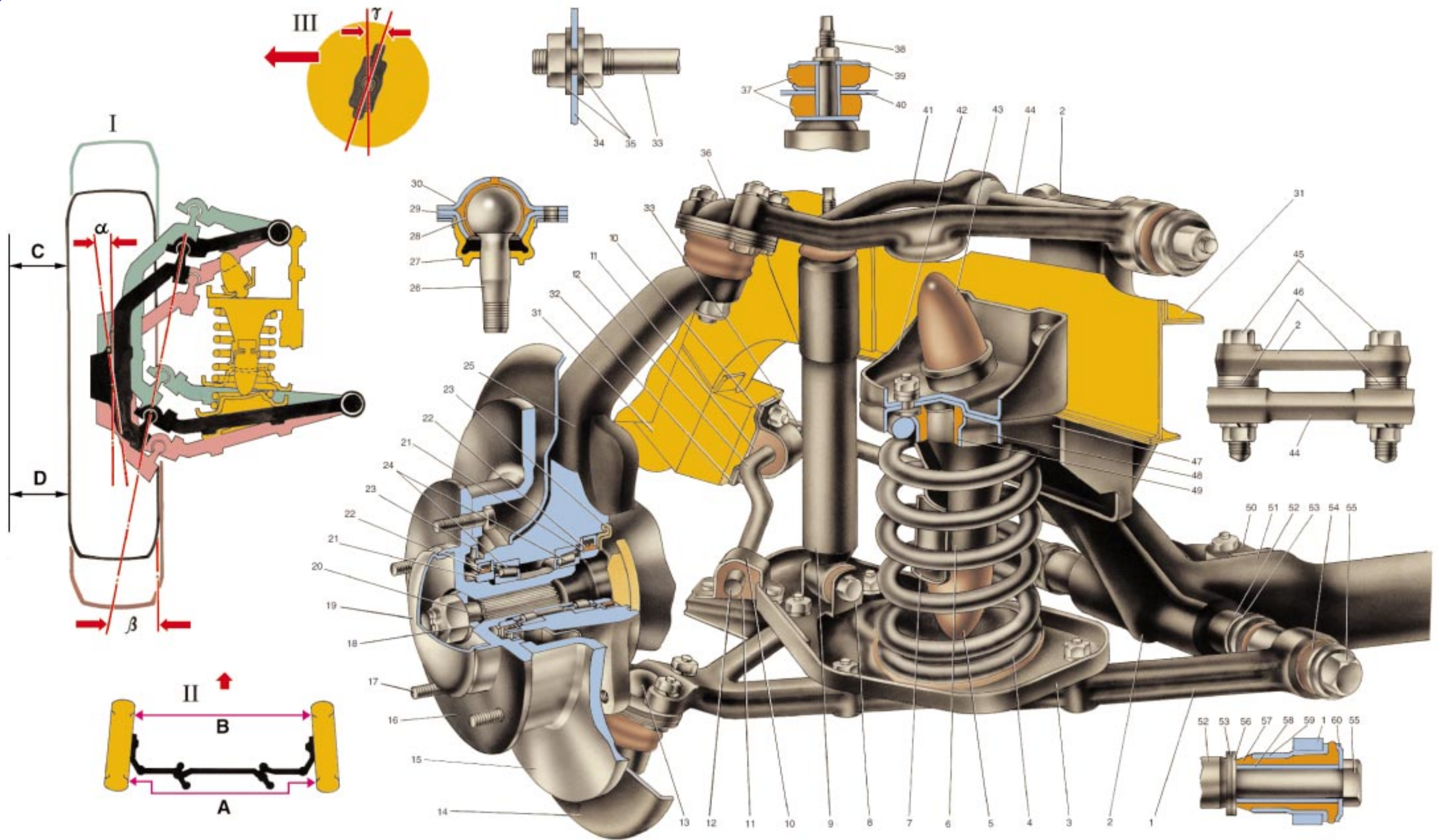

FRONT SUSPENSION

1. Lower control arm
2. Crossmember bracket
3. Coil spring lower seat
4. Coil spring
5. Compression buffer
6. Compression buffer mount strut
7. Compression restrictor
8. Shock absorber mounting bracket
9. Shock absorber
10. Anti-roll bar securing clamp
11. Anti-roll bar mounting rubber

12. Anti-roll bar
13. Lower balljoint
14. Wheel brake splash guard
15. Brake disc
16. Wheel hub
17. Wheel - to - brake disc securing bolt
18. Taper bush
19. Wheel cap
20. Outer CV joint shank
21. Oil seal bush
22. Oil seal
23. Splash guard ring
24. Wheel hub bearing

25. Stub axle
26. Ballpin
27. Boot
28. Bearing
29. Ballpin liner race
30. Ballpin bearing housing
31. Body chassis arm
32. Anti-roll bar securing plate
33. Tie-rod
34. Body-to-tie-rod mounting bracket
35. Washers
36. Upper balljoint
37. Shock absorber rod mounting bushes

38. Shock absorber rod
39. Securing washer
40. Upper securing bracket, shock absorber
41. Upper control arm
42. Recoil buffer bracket
43. Recoil buffer
44. Suspension upper arm shaft
45. Upper arm shaft securing bolts
46. Shims
47. Upper spring mounting
48. Upper spring seat
49. Spring insulator gasket
50. Crossmember-to-tie-rod securing bracket

51. Front suspension crossmember
52. Lower control arm shaft bush
53. Lower control arm washes
54. Lower arm silent block
55. Lower control arm shaft
56. Lower control arm shaft thrust washer
57. Balljoint rubber bush
58. Balljoint sleeve, inner
59. Balljoint sleeve, outer
60. Balljoint thrust washer

I. Camber ($\alpha = 0^{\circ}30' \pm 20'$) and inclination ($\beta = 11^{\circ}30'$) angles D - C = 1 ... 5 mm

II. Toe-in A - B = 2 ... 4 mm

III. Castor angle ($\gamma = 3^{\circ}30' \pm 30''$)

All wheel adjustment parameters are given for the vehicle loaded with 3136 N (320 kgf) being equal to 4 people weight and 392 N (40kgf) boot luggage.

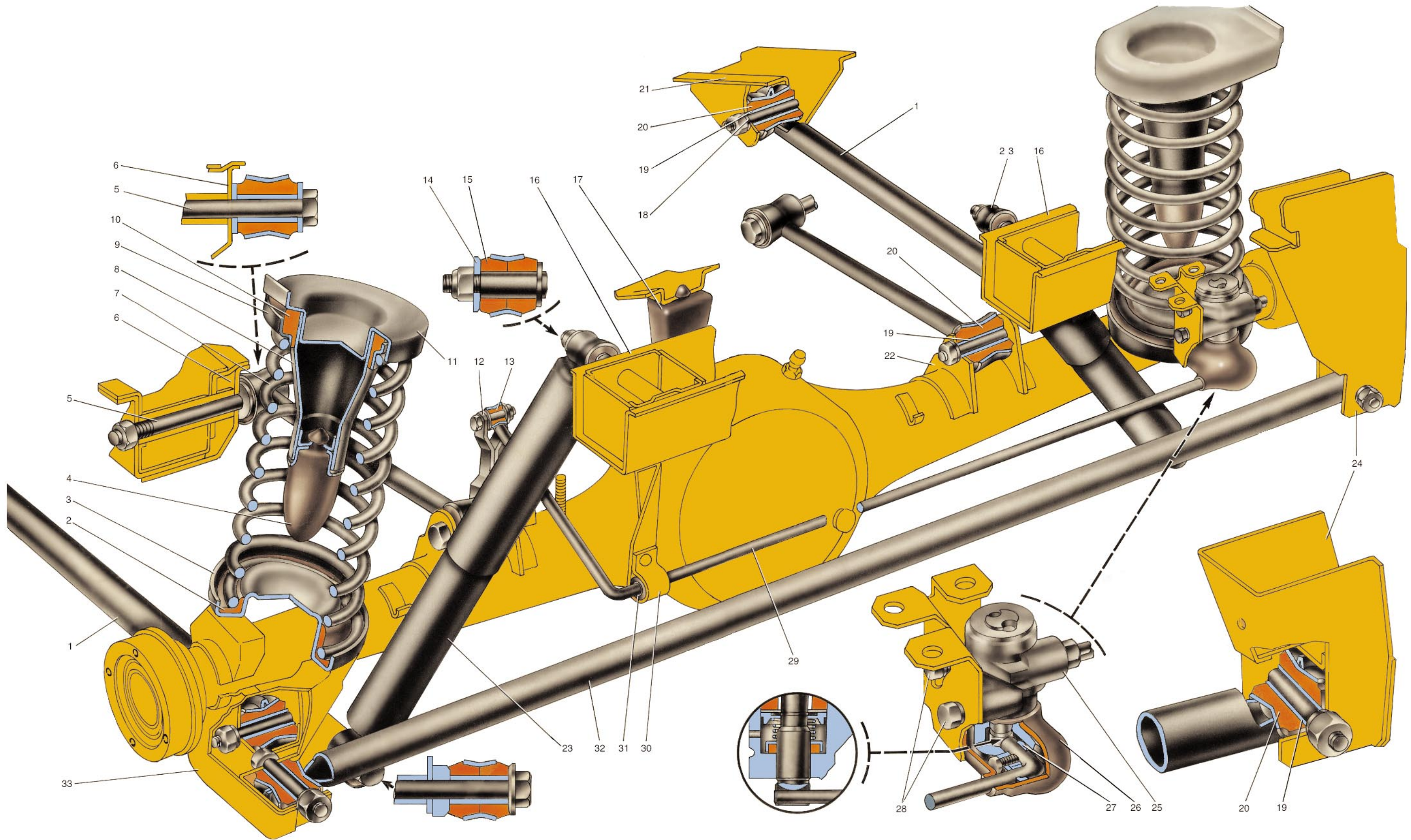

REAR SUSPENSION

- 1. Lower transverse arm
- 2. Spring insulating gasket, lower
- 3. Spring seat, lower
- 4. Compression buffer
- 5. Upper longitudinal arm securing bolt
- 6. Upper longitudinal mounting bracket
- 7. Coil spring

- 8. Compression buffer mount
- 9. Spring insulator collar, upper
- 10. Spring insulator, upper
- 11. Spring seat, upper
- 12. Rear brake pressure regulator operating rod link
- 13. Rubber bush
- 14. Shock absorber securing pin washer
- 15. Shock absorber eye rubber bush
- 16. Underbody crossmember

- 17. Additional compression buffer
- 18. Spring washer
- 19. Spacer sleeve
- 20. Rubber bush
- 21. Lower longitudinal arm mounting bracket
- 22. Upper longitudinal arm mounting bracket
- 23. Shock absorber
- 24. Body-to-transverse arm mounting bracket
- 25. Pressure regulator

- 26. Boot, pressure regulator
- 27. Operating rod shaft, pressure regulator
- 28. Securing bolts
- 29. Pressure regulator operating rod
- 30. Clamp
- 31. Thrust bush
- 32. Transverse arm
- 33. Mounting plate, transverse arm mounting bracket

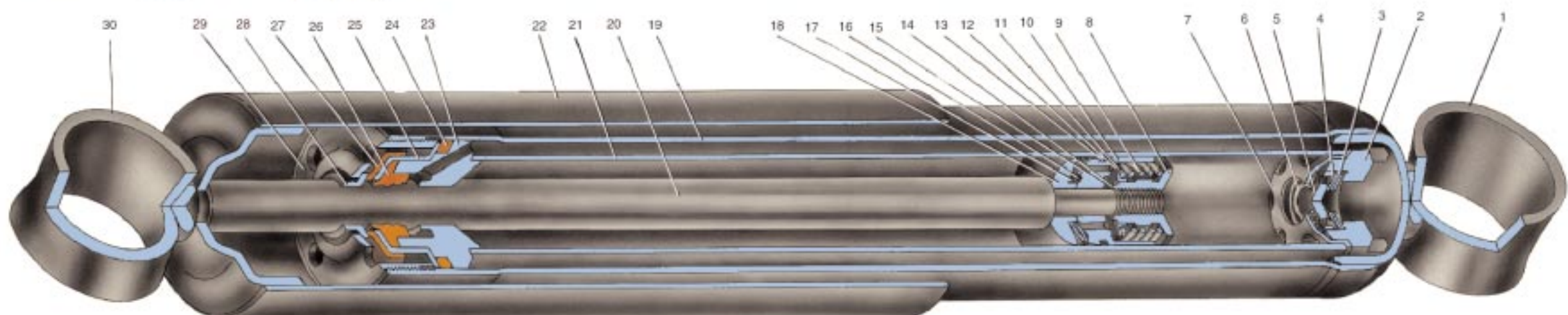
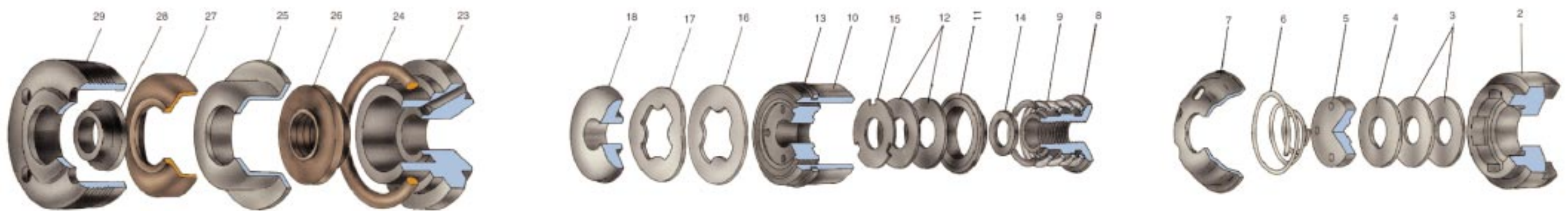
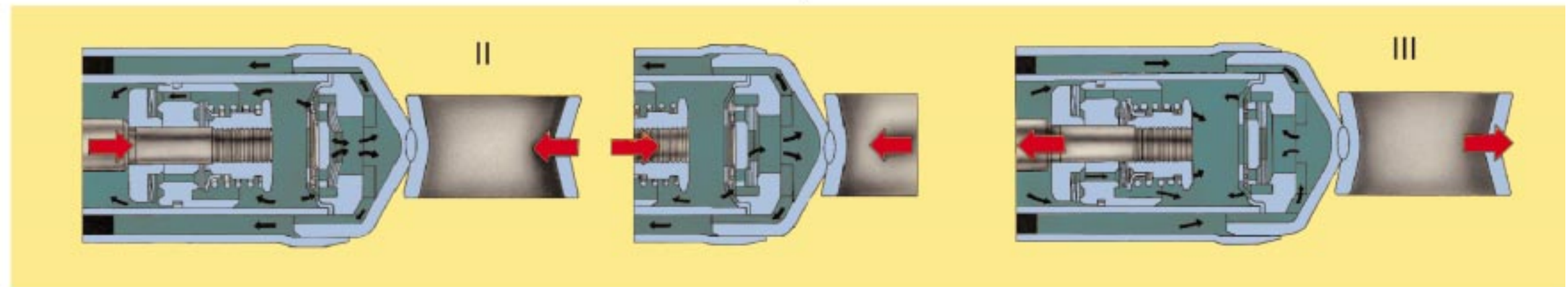
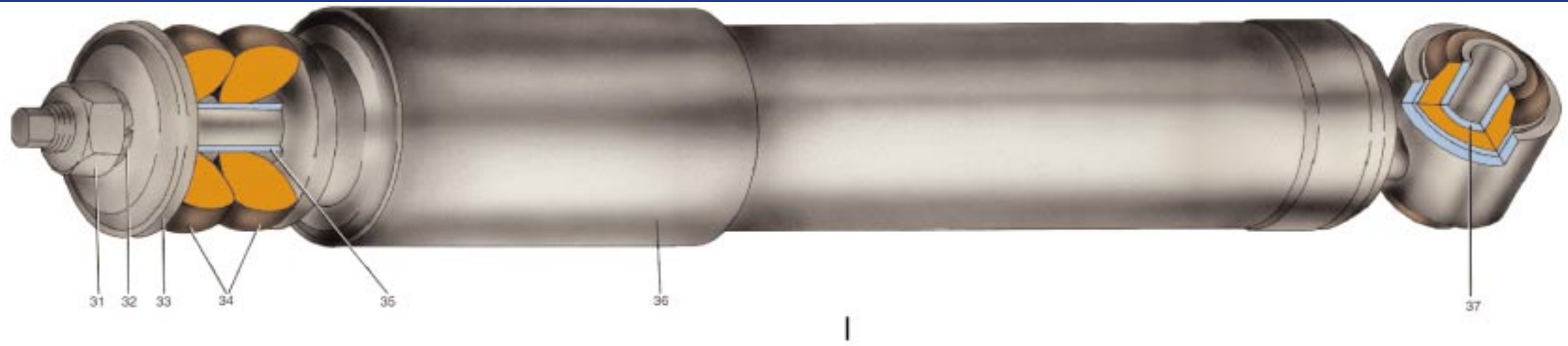

SHOCK ABSORBERS

- 1. Shock absorber eye, lower
- 2. Compression valve housing
- 3. Compression valve discs
- 4. Compression valve throttle disc
- 5. Compression valve cap

- 6. Compression valve spring
- 7. Compression valve retainer
- 8. Recoil valve nut
- 9. Recoil valve spring
- 10. Shock absorber piston
- 11. Recoil valve cap
- 12. Recoil valve discs

- 13. Piston ring
- 14. Recoil valve nut washer
- 15. Recoil valve throttle disc
- 16. By-pass valve cap
- 17. By-pass valve spring
- 18. By-pass valve restricting plate
- 19. Reservoir

- 20. Rod
- 21. Cylinder
- 22. Casing
- 23. Guide sleeve
- 24. Reservoir sealing ring
- 25. Oil seal retainer
- 26. Oil seal

- 27. Gasket
- 28. Guard ring
- 29. Reservoir nut
- 30. Shock absorber eye, upper
- 31. Upper shock absorber end securing nut
- 32. Spring washer

- 33. Washer
- 34. Mounting rubber
- 35. Spacer sleeve
- 36. Shock absorber casing
- 37. Silent block

- I. Shock absorber operation diagram
- II. Compression stroke
- III. Recoil stroke

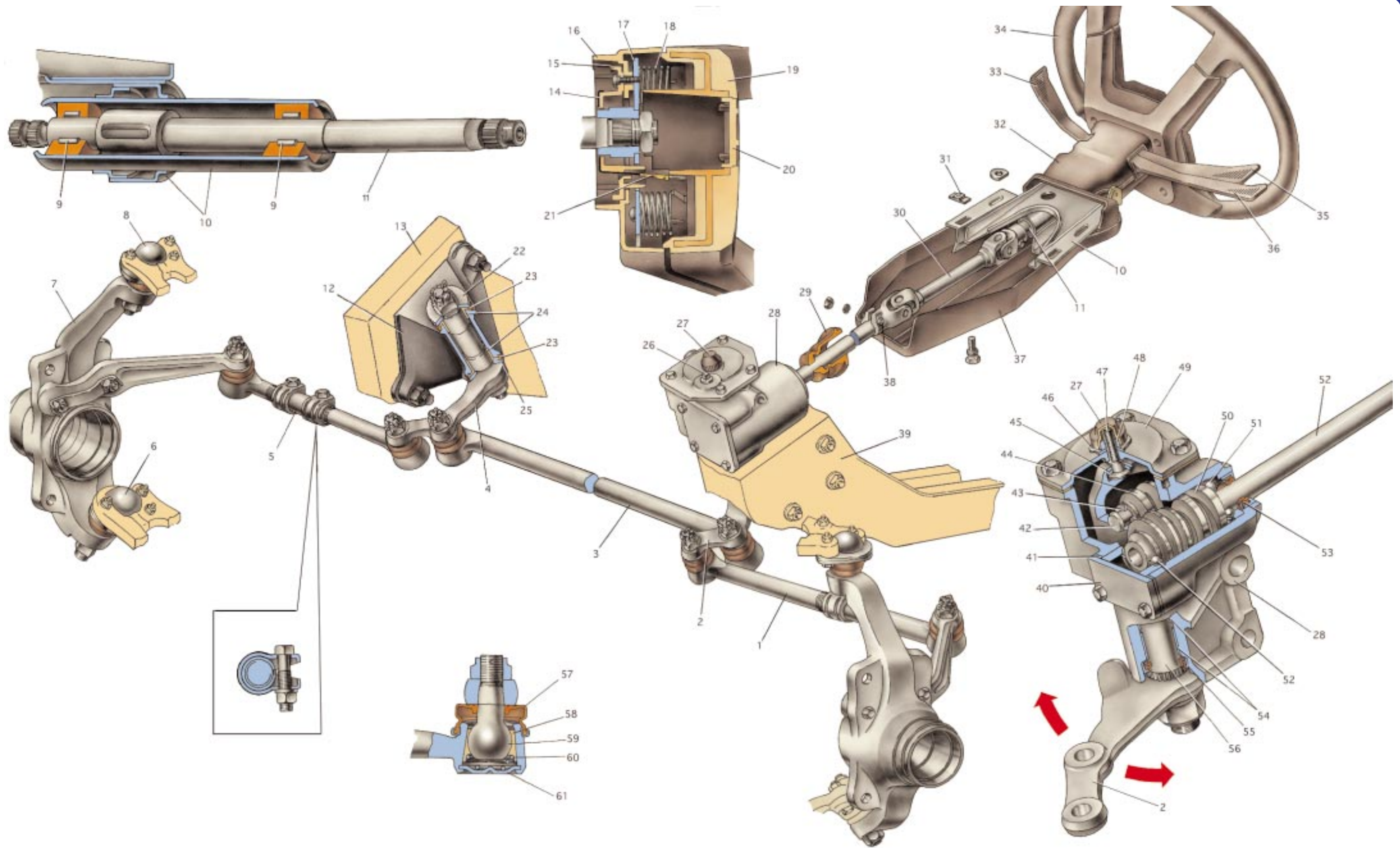

STEERING

- 1. Track rod
- 2. Drop arm
- 3. Relay rod
- 4. Idler arm
- 5. Tie-rod adjuster pin
- 6. Lower balljoint
- 7. Stub axle
- 8. Upper balljoint

- 9. Upper shaft bearing
- 10. Steering wheel mounting bracket
- 11. Upper shaft
- 12. Idler bracket
- 13. RH chassis arm, underbody
- 14. Lower contact ring
- 15. Lower contact ring retainer
- 16. Horn clamp
- 17. Upper contact ring
- 18. Horn spring

- 19. Horn push button
- 20. Cover plate
- 21. Lead
- 22. Upper washer
- 23. Seal
- 24. Idler arm shaft bush
- 25. Lower washer
- 26. Oil filler plug
- 27. Protective cap
- 28. Steering box

- 29. Steering shaft seal
- 30. Middle shaft
- 31. Securing plate, bracket front part
- 32. Upper column shroud
- 33. Wipe / wash lever
- 34. Steering wheel
- 35. Turn signal lever
- 36. Headlight lever
- 37. Lower column shroud
- 38. Pinch bolt

- 39. LH chassis arm, underbody
- 40. End cover
- 41. Shims
- 42. Roller spindle, drop arm shaft
- 43. Thrust washer
- 44. Roller
- 45. Adjuster screw plate
- 46. Lockwasher
- 47. Adjuster screw
- 48. Locknut

- 49. Top cover
- 50. Worm gear
- 51. Bearing
- 52. Worm shaft
- 53. Oil seal
- 54. Bush, drop arm shaft
- 55. Oil seal, drop arm shaft
- 56. Drop arm shaft
- 57. Ballpin protective cap
- 58. Ballpin liner

- 59. Ballpin
- 60. Spring
- 61. End plug

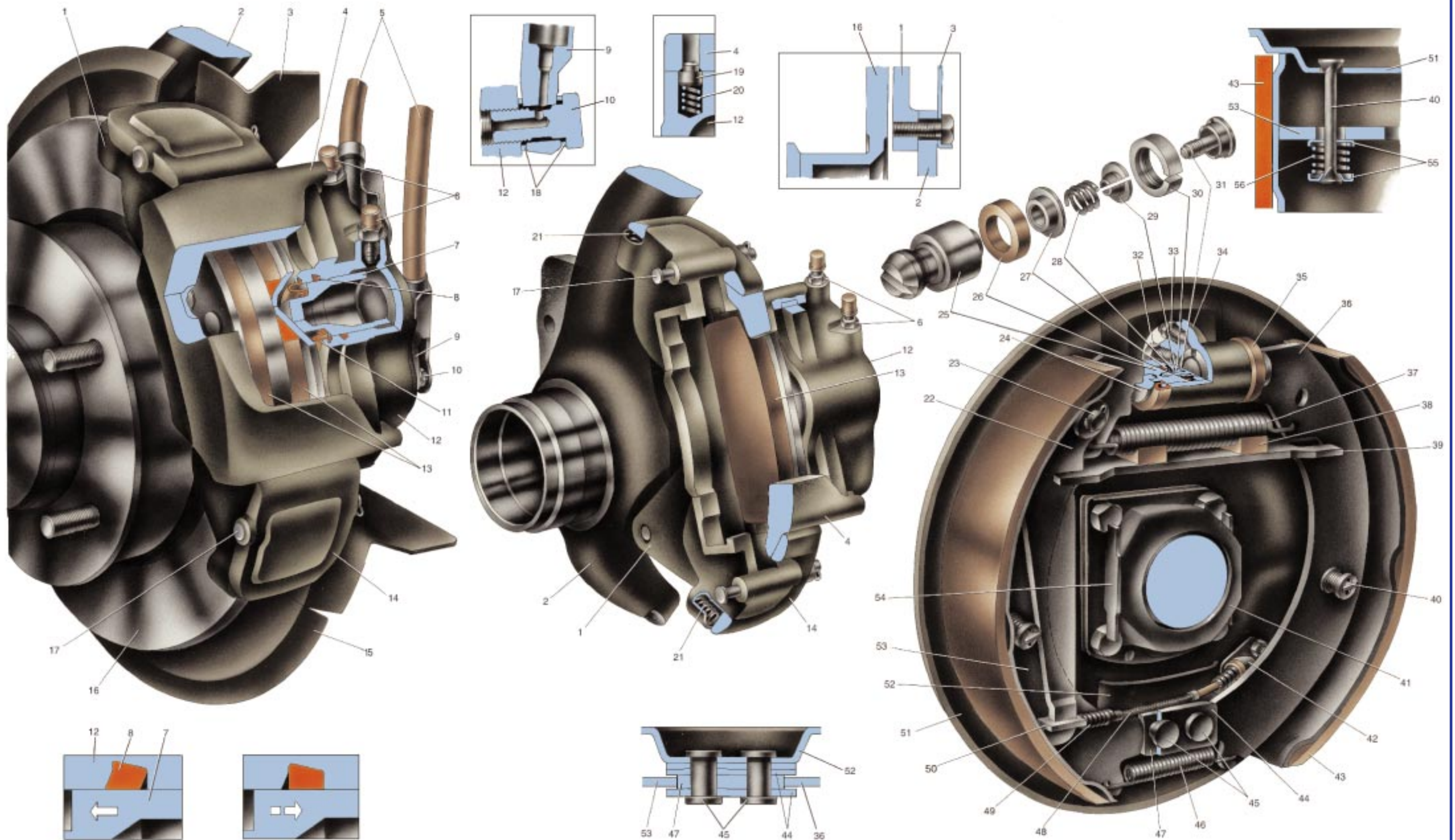

BRAKE MECHANISM

- | | | | | | |
|-------------------------------------------------------------------------------------------------------------------------------------------------------------------------------------------------------------------------------------------------------------------------------------|-----------------------------------------------------------------------------------------------------------------------------------------------------------------------------------------------------------------------------------------------------------------------------------------------------------------------------------------------------------------------|---------------------------------------------------------------------------------------------------------------------------------------------------------------------------------------------------------------------------------------------------------------------------------------------------------------------------------------------------|----------------------------------------------------------------------------------------------------------------------------------------------------------------------------------------------------------------------------------------------------------------------------------------------------------------------------------------------------------------------------------|--------------------------------------------------------------------------------------------------------------------------------------------------------------------------------------------------------------------------------------------------------------------------------------------------------------------------------------------------------------------------|------------------------------------------------------------------------------------------------------------------|
| <ul style="list-style-type: none"> 1. Carrier 2. Stub axle 3. Splash guard 4. Caliper 5. Brake hoses 6. Union to expel air 7. Front brake wheel cylinder piston 8. Sealing ring 9. End piece | <ul style="list-style-type: none"> 10. Hose union bolt 11. Piston protective cap 12. Cylinder housing 13. Brake pad 14. Caliper clamping lever 15. Front brake splash guard 16. Brake disc 17. Clamping lever shaft 18. Gaskets 19. Detent 20. Detent spring | <ul style="list-style-type: none"> 21. Clamping lever spring 22. Shoe manual return lever 23. Shaft 24. Shoe abutment plate 25. Wheel cylinder piston 26. Seal 27. Backing cup 28. Spring 29. Retainers 30. Thrust ring 31. Thrust screw | <ul style="list-style-type: none"> 32. Brake fluid inlet union 33. Rear brake bleed screw 34. Rear brake wheel cylinder 35. Dust seal 36. Brake pad 37. Upper return spring 38. Mounting rubber 39. Expander strut 40. Steady post 41. Oil deflector 42. Rear cable end | <ul style="list-style-type: none"> 43. Friction linings 44. Cover plates 45. Rivet 46. Lower return spring 47. Mounting plate 48. Handbrake rear cable 49. Cable return spring 50. Rear cable end 51. Rear brake backplate 52. Cable guide plate 53. Brake shoe | <ul style="list-style-type: none"> 54. Bolt retainer 55. Spring cups 56. Spring |
|-------------------------------------------------------------------------------------------------------------------------------------------------------------------------------------------------------------------------------------------------------------------------------------|-----------------------------------------------------------------------------------------------------------------------------------------------------------------------------------------------------------------------------------------------------------------------------------------------------------------------------------------------------------------------|---------------------------------------------------------------------------------------------------------------------------------------------------------------------------------------------------------------------------------------------------------------------------------------------------------------------------------------------------|----------------------------------------------------------------------------------------------------------------------------------------------------------------------------------------------------------------------------------------------------------------------------------------------------------------------------------------------------------------------------------|--------------------------------------------------------------------------------------------------------------------------------------------------------------------------------------------------------------------------------------------------------------------------------------------------------------------------------------------------------------------------|------------------------------------------------------------------------------------------------------------------|

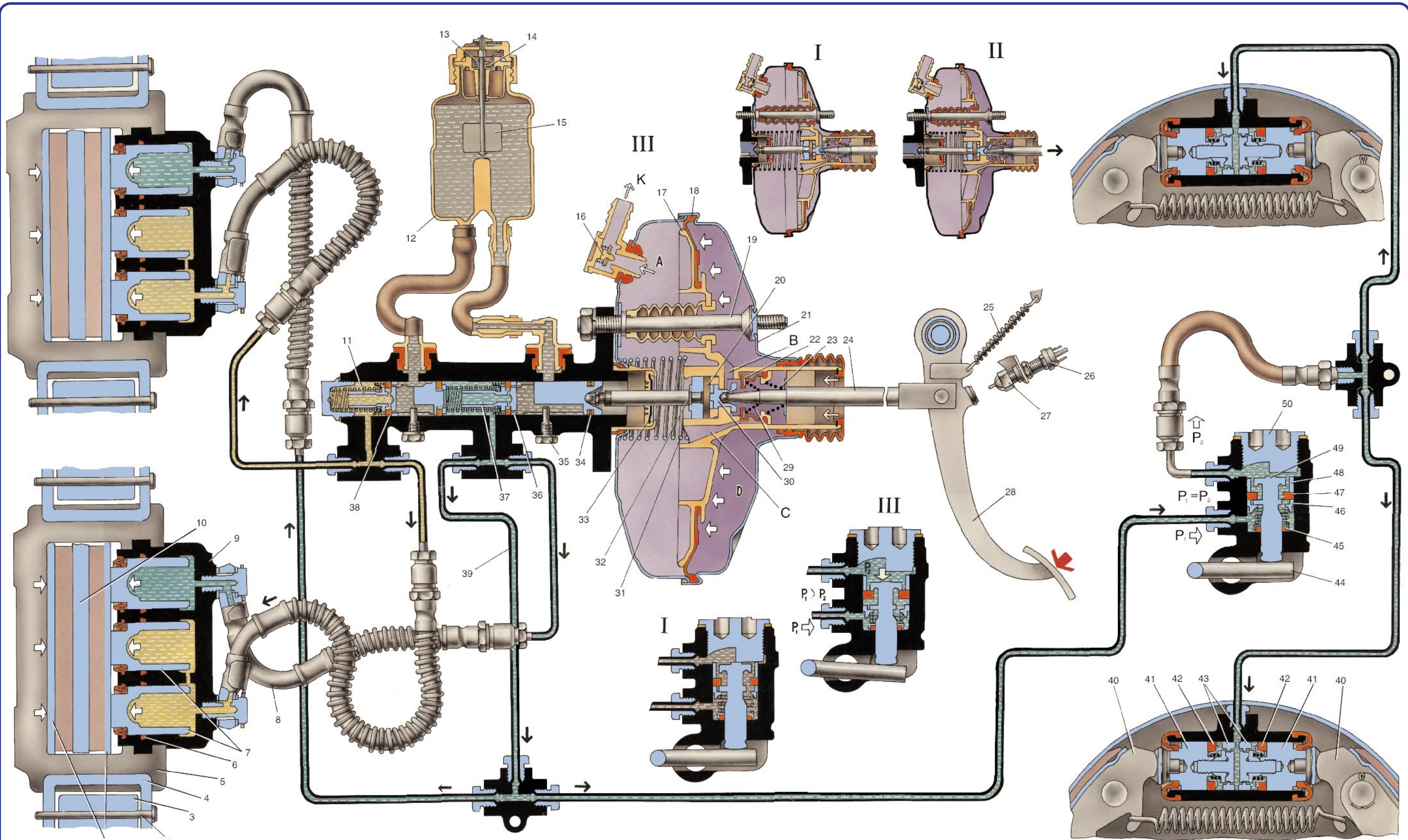

BRAKE OPERATION DIAGRAM

- 1. Brake pads
- 2. Hold-down lever shaft
- 3. Carrier
- 4. Caliper hold-down lever
- 5. Caliper
- 6. Piston sealing ring
- 7. Wheel cylinder pistons, primary circuit
- 8. Brake hose, secondary circuit
- 9. Cylinder housing

- 10. Brake disc
- 11. Master cylinder primary circuit operating piston
- 12. Hydraulic fluid reservoir
- 13. Sliding contact
- 14. Fixed contact
- 15. Float
- 16. Vacuum valve
- 17. Servo unit valve housing
- 18. Diaphragm
- 19. Tie-rod

- 20. Reaction disc
- 21. Rear shell
- 22. Vacuum unit valve
- 23. Return spring
- 24. Input rod
- 25. Pedal return spring
- 26. Stop light switch
- 27. Stop light switch tip
- 28. Brake pedal
- 29. Valve spring
- 30. Piston

- 31. Valve housing return spring
- 32. Output rod
- 33. Retainer
- 34. Sealing ring
- 35. Piston stroke limiter screw
- 36. Bush
- 37. Secondary circuit operating piston
- 38. Seal
- 39. Secondary circuit pipeline
- 40. Brake shoes
- 41. Rear brake wheel cylinder piston

- 42. Piston seal
- 43. Thrust rings
- 44. Pressure regulator operating rod
- 45. Sealing ring
- 46. Spring seat
- 47. Piston head seal
- 48. Bush
- 49. Pressure regulator piston
- 50. End plug

- A. Vacuum cavity
- B. Atmosphere - to - valve inner cavity port
- C. Valve inner cavity - to - vacuum port
- K. To engine intake pipe
- D. Atmospheric cavity
- I. Brake pedal released
- II. Brake off
- III. Brake applied

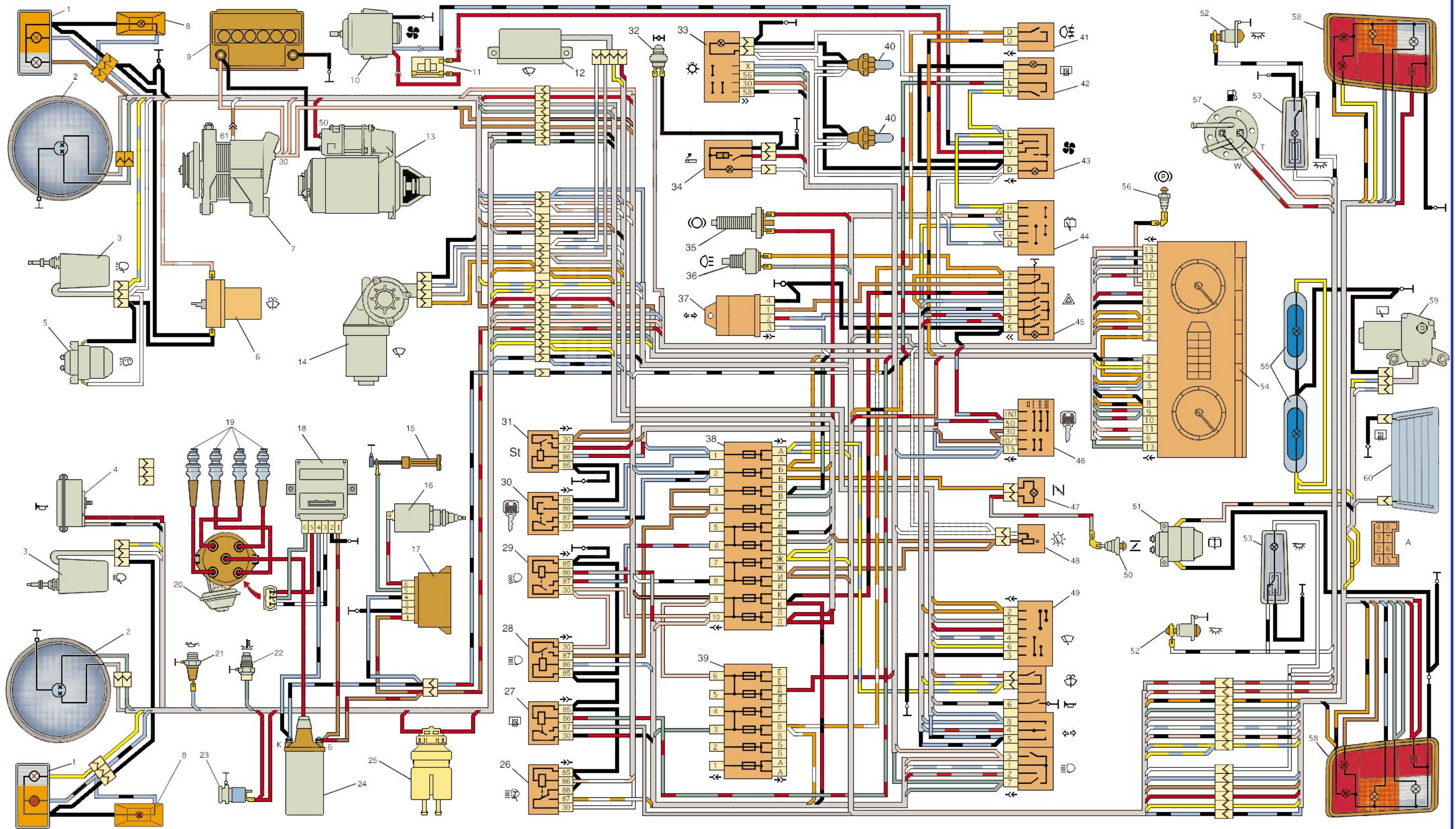

**WIRING DIAGRAM
FOR ELECTRIC EQUIPMENT
OF VAZ 21213 VEHICLE**

- 1. Front lights
- 2. Headlights
- 3. Headlight wiper motor
- 4. Horn
- 5. Headlight washer motor
- 6. Windscreen washer motor
- 7. Alternator

- 8. Turn indicator side repeater lights
- 9. Battery
- 10. Heater unit motor
- 11. Additional resistor for heater motor
- 12. Intermittent wiper relay
- 13. Starter motor
- 14. Windscreen wiper motor
- 15. Carburettor limit switch
- 16. Carburettor electromagnetic valve
- 17. Carburettor electromagnetic valve control unit
- 18. Ignition module

- 19. Spark plugs
- 20. Ignition distributor
- 21. Oil pressure warning light sensor
- 22. Temperature indicator sensor
- 23. Socket for inspection lamp
- 24. Ignition coil
- 25. Brake fluid level warning lamp sensor
- 26. Headlight wiper/wash relay
- 27. Heated rear window relay
- 28. Headlight main beam relay
- 29. Headlight dipped beam relay
- 30. Ignition relay

- 31. Starter "on" relay
- 32. Differential lock warning lamp switch
- 33. Exterior lighting switch
- 34. Cigarette lighter
- 35. Stop-signal switch
- 36. Reversing light switch
- 37. Intermittent direction indicator / hazard warning lights relay
- 38. Main fuse box
- 39. Additional fuse box
- 40. Heater controls illumination bulbs
- 41. Rear fog light switch

- 42. Heated rear window switch
- 43. Heater motor switch
- 44. Rear window wipe/wash switch
- 45. Hazard warning lights switch
- 46. Ignition switch
- 47. Carburettor choke warning lamp
- 48. Instrument lighting switch
- 49. 3-lever column switch
- 50. Choke warning lamp switch
- 51. Rear window washer motor
- 52. Door pillar light switch
- 53. Interior lights

- 54. Instrument cluster
 - 55. Number plate lights
 - 56. Handbrake warning light switch
 - 57. Fuel level / fuel remainder sensor
 - 58. Tail lights
 - 59. Rear window wiper motor
 - 60. Rear window heating element
- A.** Pin numbers for column switch connectors

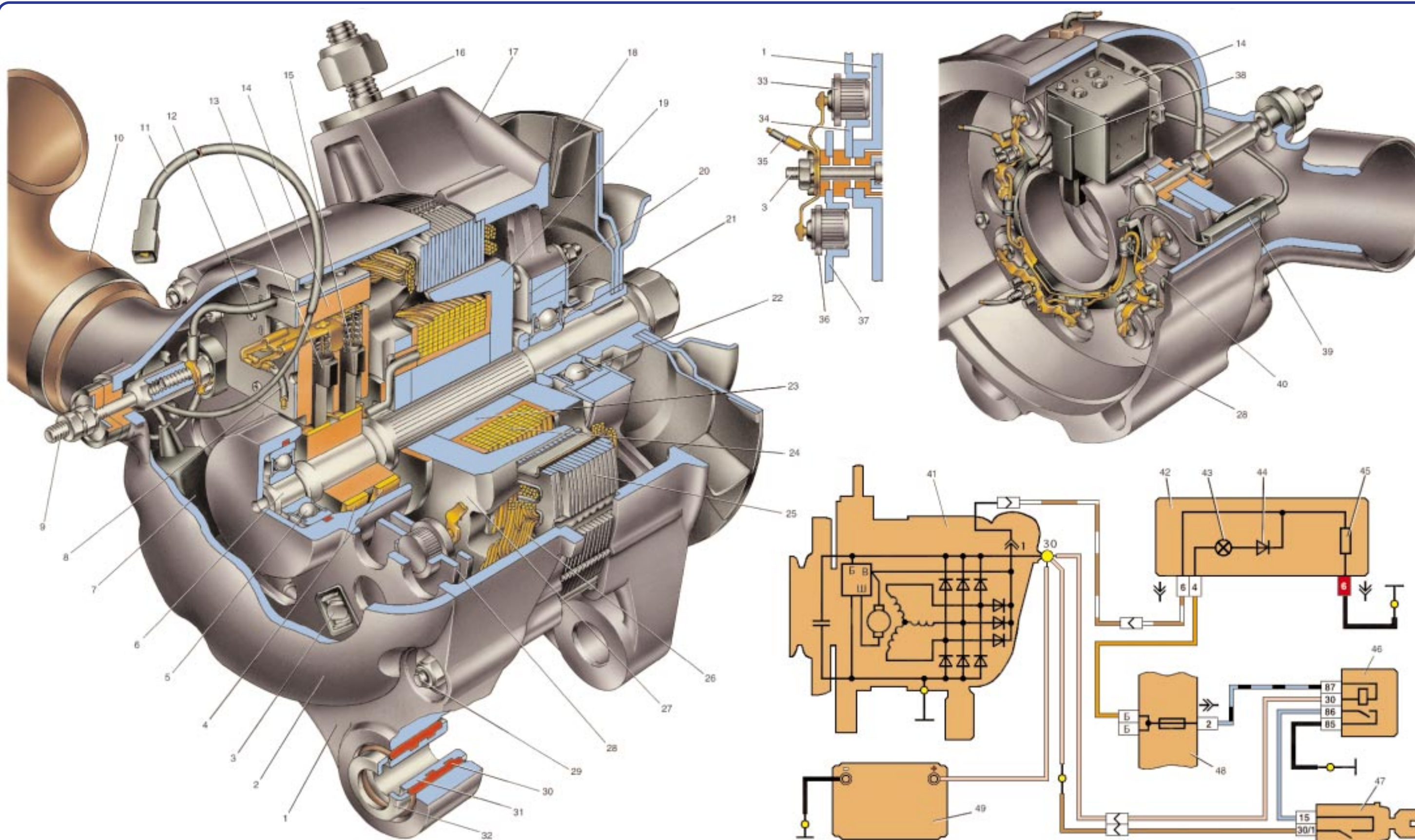

ALTERNATOR

Specification

Max.current at 13 V and rotor rate 5,000 RPM, A 55
 Adjustable range of voltage, V 14.1 ± 0.5
 Engine-to-alternator ratio 1 : 2.04

- 1. Slip ring end housing
- 2. Casing
- 3. Securing bolt, diode plate-to-stator winding phased pins

- 4. Slip rings
- 5. Armature shaft ballbearing, slip ring end
- 6. Rotor shaft
- 7. Condenser 2.2 uF± 20%
- 8. Common output lead, supplementary diodes
- 9. Terminal bolt extension (alternator '30' output for power consumption)
- 10. Air intake
- 11. Alternator output '61' lead
- 12. Voltage regulator output 'B' lead
- 13. Brush connected to voltage regulator 'B' output
- 14. Voltage regulator

- 15. Brushes connected to voltage regulator 'Ш' output
- 16. Alternator - to - tensioner securing stud
- 17. Drive end housing
- 18. Fan impeller with alternator pulley
- 19. Rotor pole tip, drive end
- 20. Bearing securing washers
- 21. Spacer
- 22. Rotor shaft ballbearing, drive end
- 23. Steel sleeve
- 24. Rotor winding (field winding)
- 25. Stator
- 26. Stator winding

- 27. Rotor pole face, slip ring end
- 28. Rectifier unit
- 29. Alternator pinch bolt
- 30. Buffer bush
- 31. Bush
- 32. Hold-down bush
- 33. Negative gate with "-" rectified current on the housing
- 34. Negative gate retainer
- 35. Stator winding phase pinout
- 36. Positive gate with "+" rectified current on the housing
- 37. Positive gate retainer
- 38. Brush holder

- 39. '61' output (common output of supplementary diodes)
- 40. Supplementary diode (for field winding)
- 41. Alternator
- 42. Instrument cluster
- 43. Battery charge warning light
- 44. Diode
- 45. Resistor 51 Ohm 5 W
- 46. Ignition relay
- 47. Ignition switch
- 48. Main fuse box
- 49. Battery

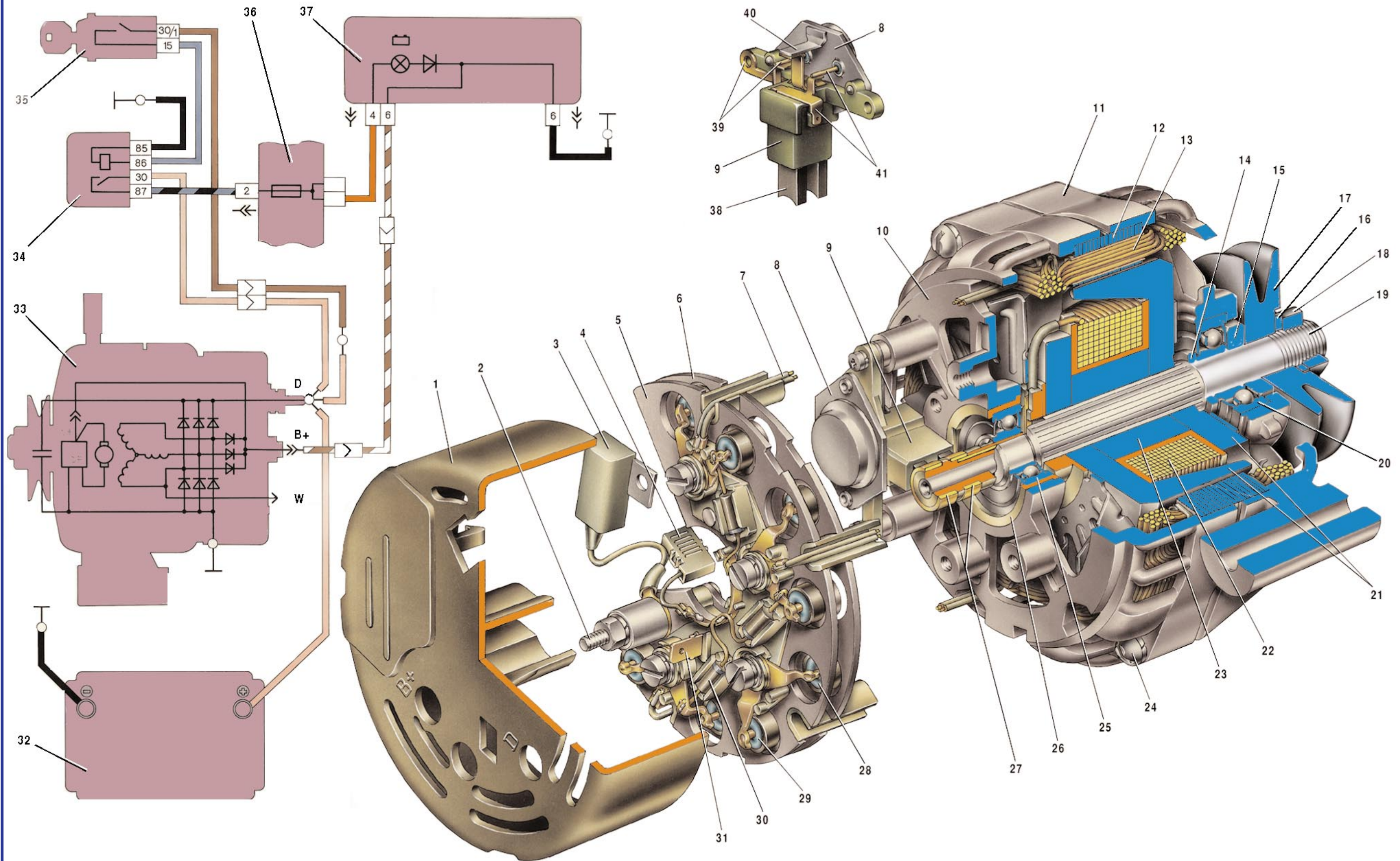

**ALTERNATOR 94.3701
(for injection vehicles)**

Specification

Maximum current at 13 v
and rotor 6000 RPM, A80
Adjustable range of voltage, v13,2-14,7
Engine - to - alternator ratio1 : 2.4

- | | | | | |
|-------------------------------------------------------------------------------------------|--------------------|--------------------------------|---------------------------------------------------------|---------------------------------------|
| 1. Housing | 9. Brush holder | 18. Nut | 27. Slip rings | 35. Ignition switch |
| 2. "B+" terminal for power consumption | 10. Rear cover | 19. Rotor shaft | 28. Negative diode | 36. Fusebox |
| 3. Interference suppression capacitor 2.2 uF | 11. Front cover | 20. Rotor shaft bearing, front | 29. Positive diode | 37. Battery charge warning light |
| 4. Common terminal of additional diodes (connected to "D+" terminal of voltage regulator) | 12. Stator core | 21. Rotor pole ends | 30. Additional diode | 38. Brush |
| 5. Holder for rectifier positive diodes | 13. Stator winding | 22. Rotor winding | 31. "D" terminal (common terminal of additional diodes) | 39. Earth terminal, voltage regulator |
| 6. Holder for rectifier negative diodes | 14. Spacer | 23. Bush | 32. Battery | 40. "DF" terminal, voltage regulator |
| 7. Starter winding terminals | 15. Washer | 24. Clamp screw | 33. Alternator | 41. "D+" terminal, voltage regulator |
| 8. Voltage regulator | 16. Taper washer | 25. Rotor bearing, rear | 34. Ignition relay | |
| | 17. Pulley | 26. Bush, bearing | | |

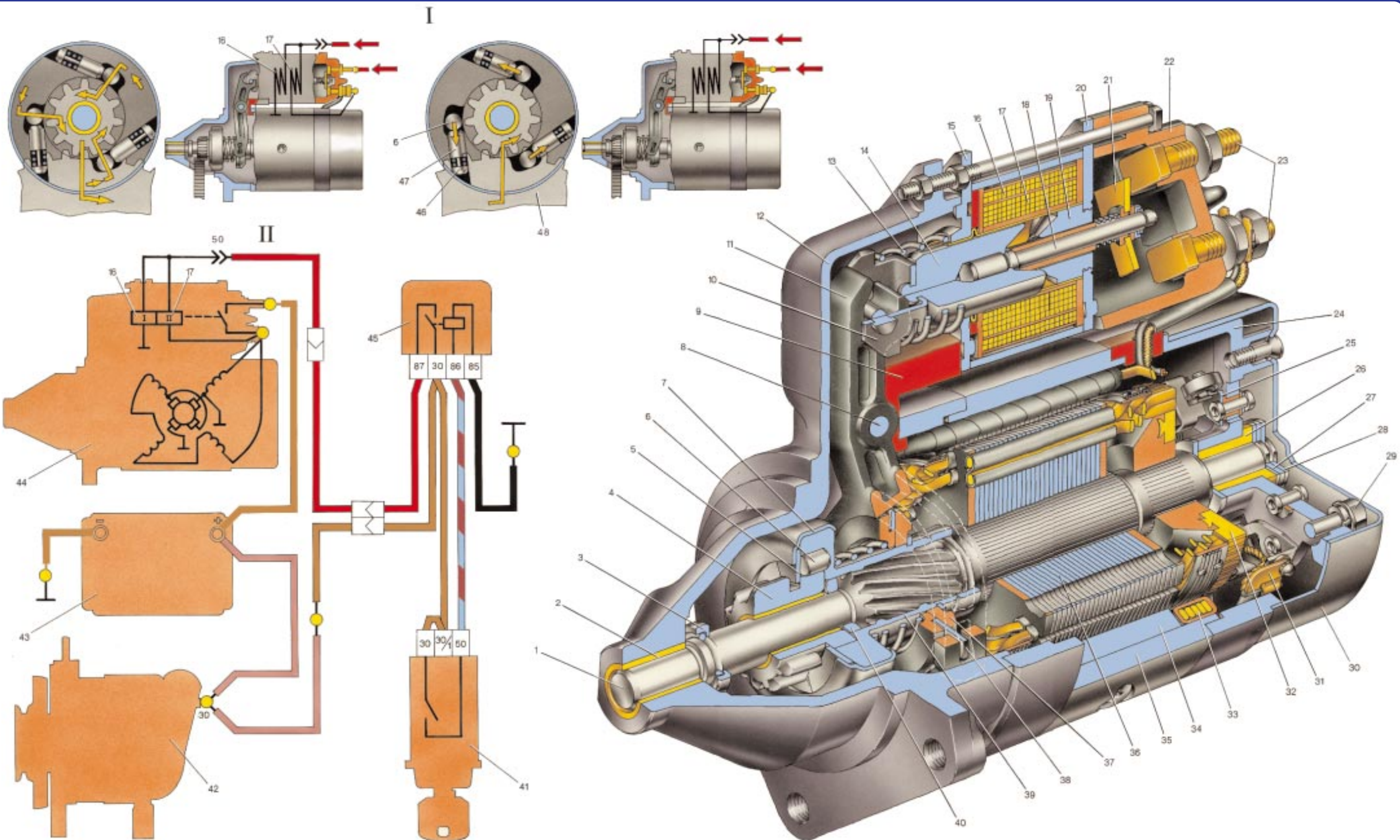

STARTER MOTOR

Specification

Rated power, kW	1.3
Current consumption at rated power, A, not greater	260
Current consumption at "brake on", A, not greater	500
Current consumption at idle, A, not greater	60
Rotation direction (drive end)	clockwise

- 1. Armature shaft
- 2. Bush, starter motor cover
- 3. Pinion stop collar
- 4. Driving pinion / clutch inner ring assy
- 5. Thrust half-ring
- 6. Overrun clutch roller
- 7. Overrun clutch casing
- 8. Operating lever pivot pin
- 9. Plug
- 10. Relay armature drive link
- 11. Operating lever
- 12. Drive-end cover
- 13. Relay armature return spring
- 14. Starter motor relay armature
- 15. Front relay flange
- 16. Relay holding winding
- 17. Relay plunging winding
- 18. Armature core bar
- 19. Relay core
- 20. Core flange
- 21. Contact disc
- 22. Relay cover
- 23. Relay contact bolts
- 24. Commutator end cover
- 25. Positive brush holder
- 26. Starter motor cover bush

- 27. End float shim
- 28. Lock washer
- 29. Clamp bolt
- 30. Casing
- 31. Stator winding series coils pinout
- 32. Commutator
- 33. Stator winding series coil
- 34. Stator pole
- 35. Starter motor housing
- 36. Armature core
- 37. Limiter plate
- 38. Drive ring
- 39. Hub / clutch outer ring

- 40. Overrun clutch hub liner
- 41. Ignition switch
- 42. Alternator
- 43. Battery
- 44. Starter motor
- 45. Starter relay
- 46. Guide bar
- 47. Plunger
- 48. Flywheel

I. Overrun clutch operating diagram
 II. Starter motor connection diagram

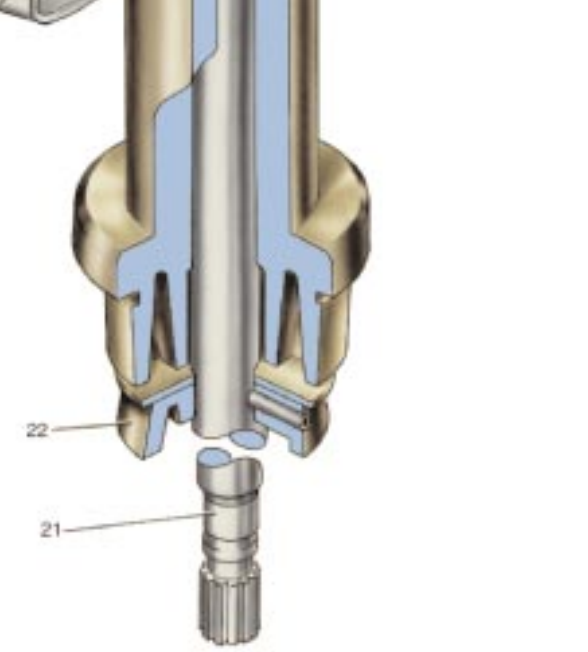
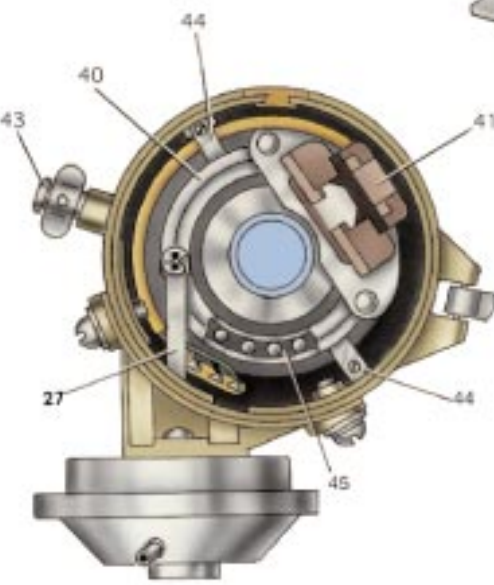
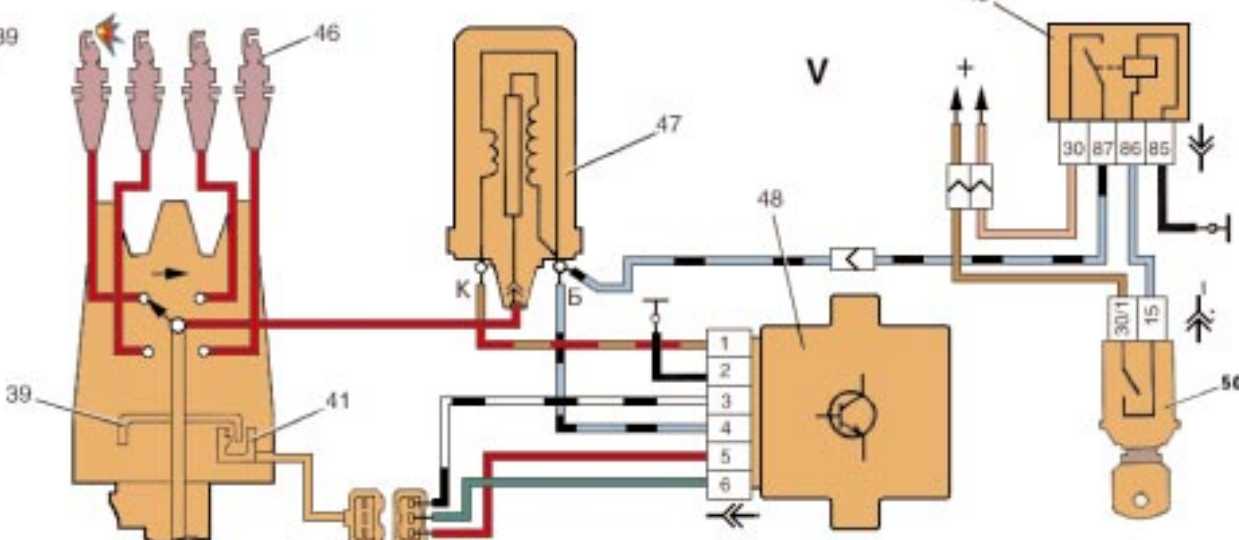
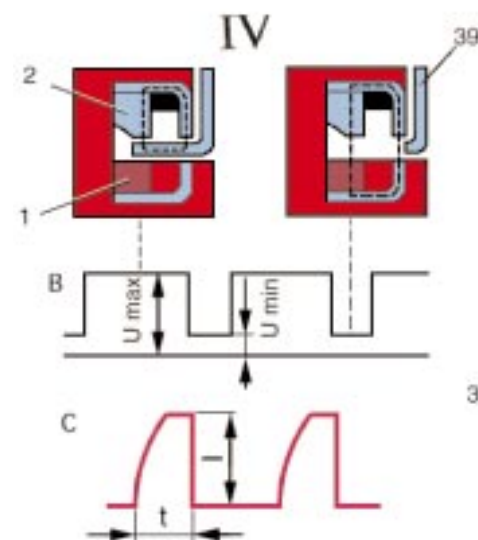
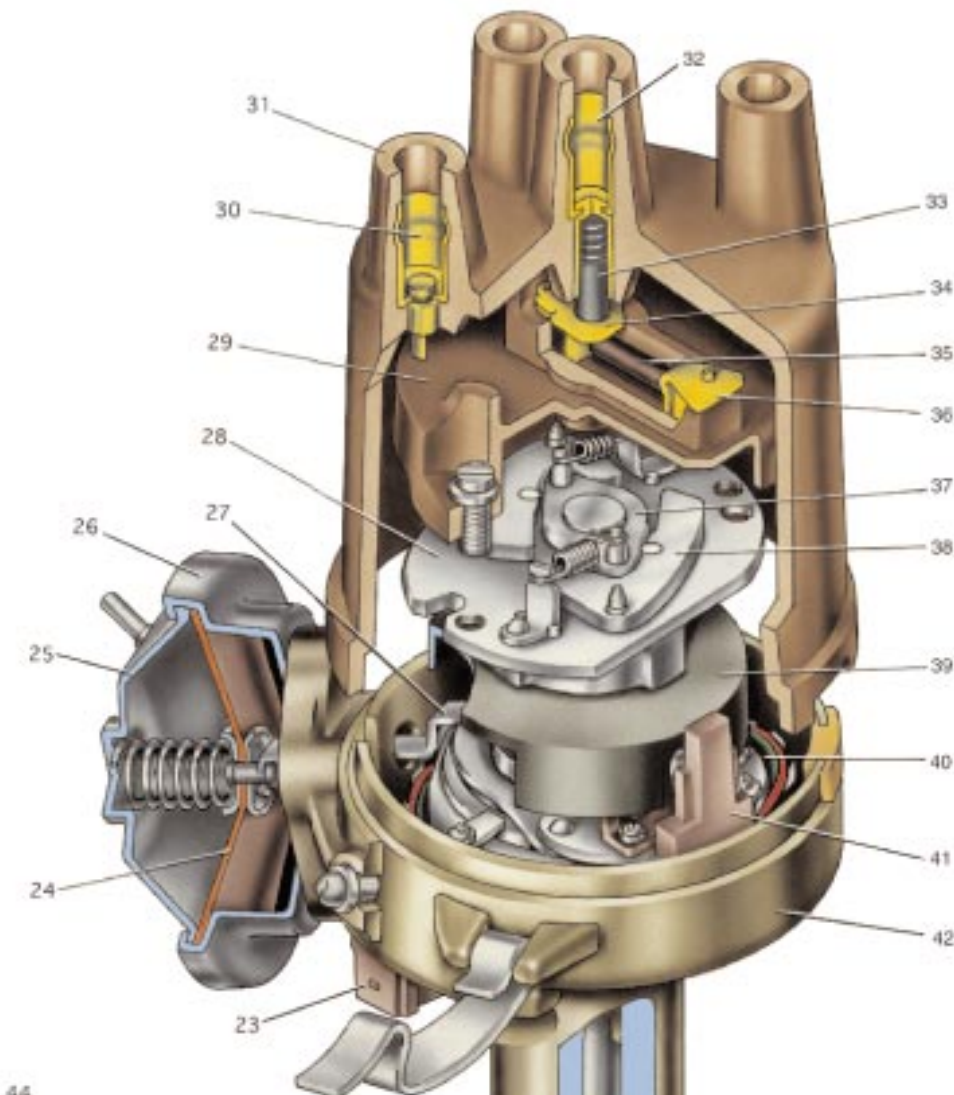
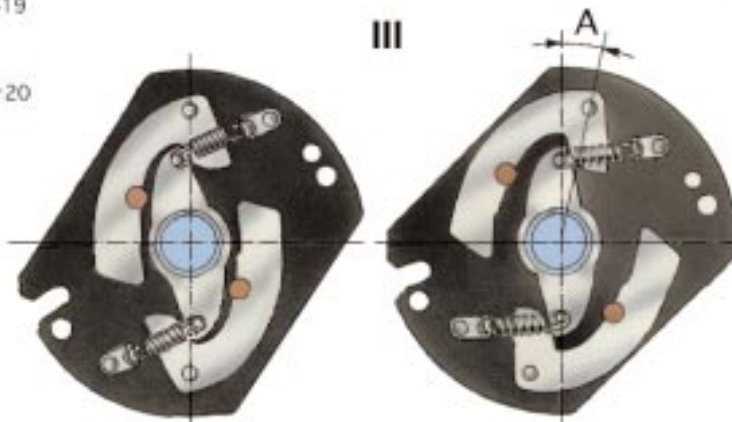
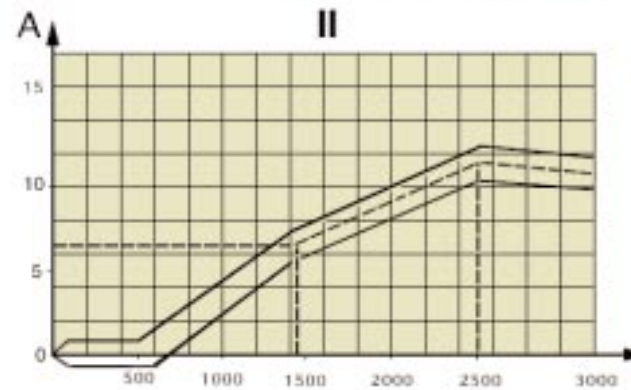
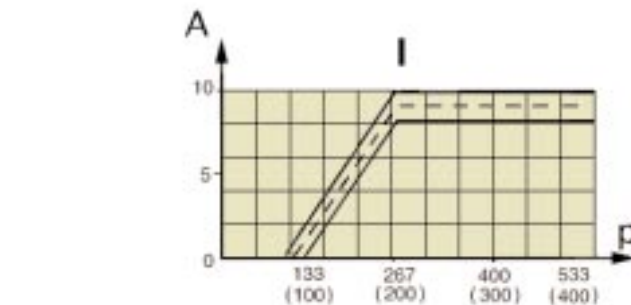
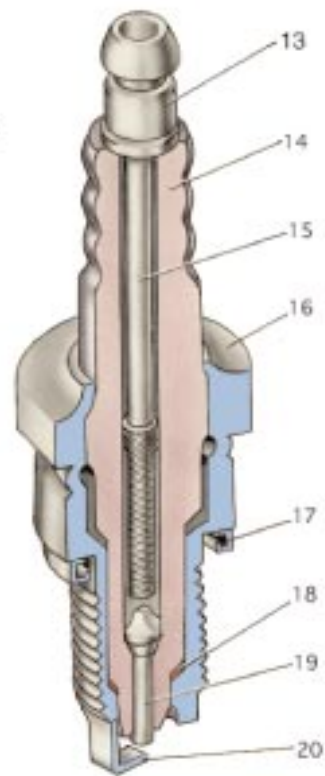
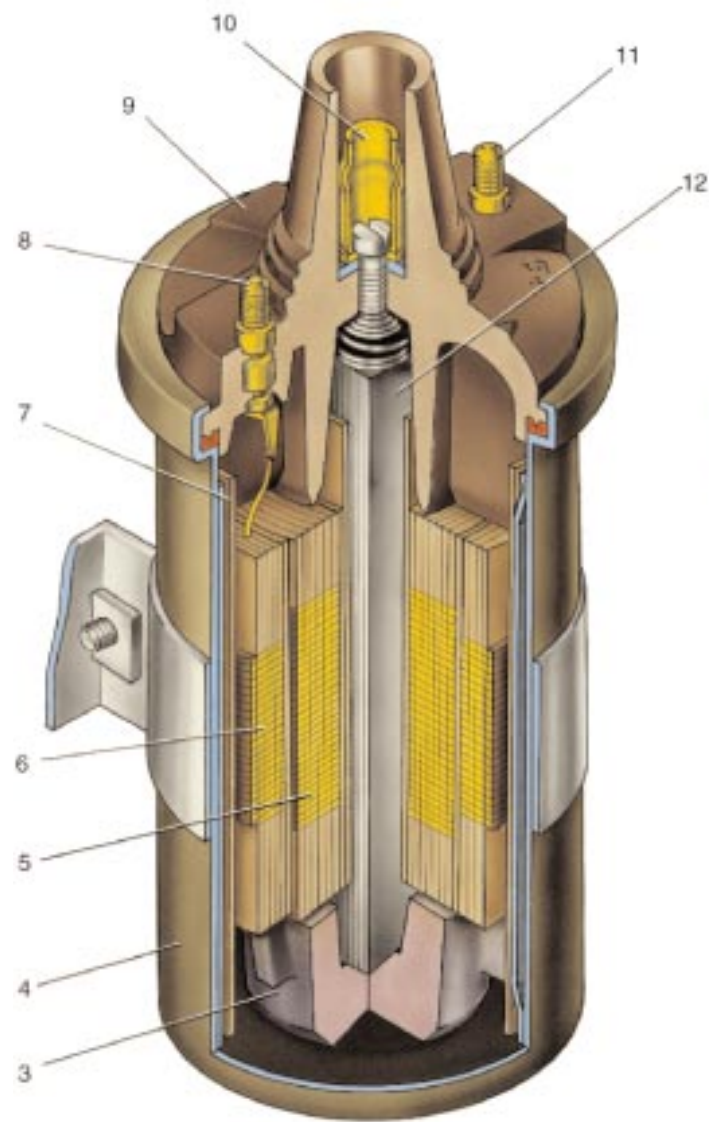

IGNITION SYSTEM

- 1. Semiconductor element with integrated circuit
- 2. Permanent magnet
- 3. Insulator
- 4. Ignition coil housing
- 5. Secondary winding
- 6. Primary winding
- 7. Outer magnetic duct
- 8. Primary winding end 'K' terminal
- 9. Cover

- 10. High tension terminal
- 11. 'B' terminal, primary winding start / secondary winding end
- 12. Core
- 13. Contact nut
- 14. Spark plug insulator
- 15. Core bar
- 16. Spark plug body
- 17. Sealing ring
- 18. Heat screening washer
- 19. Centre electrode
- 20. Side electrode

- 21. Distributor shaft
- 22. Shaft oil slinger
- 23. Socket
- 24. Diaphragm
- 25. Vacuum advance cover
- 26. Vacuum advance housing
- 27. Vacuum unit operating arm
- 28. Advance unit bearing plate
- 29. Distributor rotor
- 30. Side electrode with terminal for lead to ignition switch
- 31. Ignition distributor cap

- 32. Centre electrode with terminal for coil lead
- 33. Centre electrode carbon contact
- 34. Centre rotor contact
- 35. 1000 Ohm resistor for interference suppression
- 36. Outer rotor contact
- 37. Centrifugal regulator plate
- 38. Advance unit governor weight
- 39. Screen
- 40. Hall sensor plate
- 41. Hall sensor
- 42. Distributor body

- 43. Oiler body
- 44. Bearing lock plate
- 45. Bearing
- 46. Spark plugs
- 47. Ignition coil
- 48. Ignition module
- 49. Ignition relay
- 50. Ignition switch

A - ignition timing, degrees
n - distributor shaft rotation rate, RPM

III. Centrifugal advance operation diagram:
A - ignition timing

IV. Hall sensor operation diagram:
B - voltage pulses (U) at sensor output
C - current pulses (I) in ignition coil primary winding; t - current accumulation time

V. Ignition system diagram

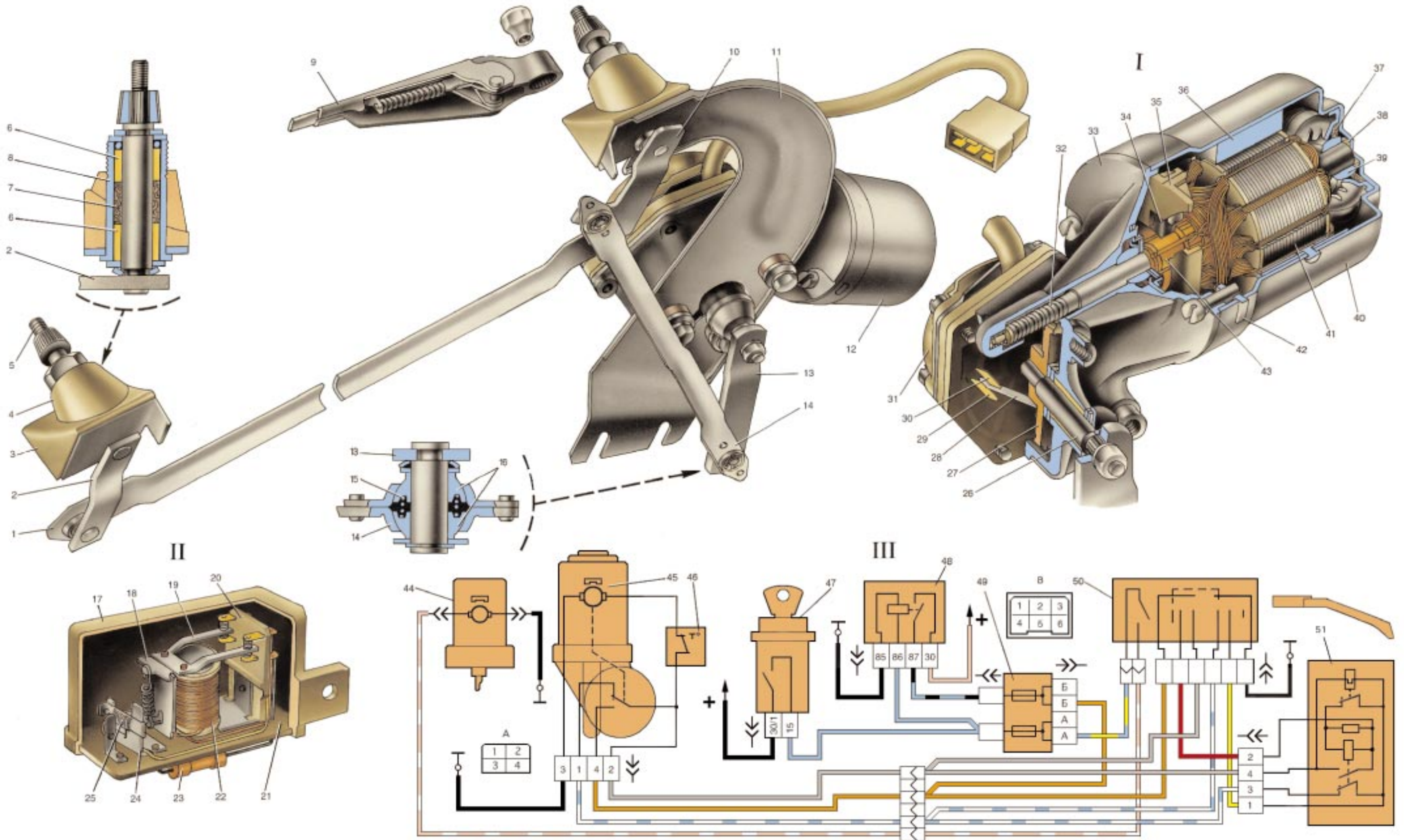

WINDSCREEN WIPER

- 1. Linking rod
- 2. LH operating arm
- 3. Inner mounting bush
- 4. Outer mounting bush
- 5. Shaft
- 6. Bushes

- 7. Felt
- 8. Bracket
- 9. Wiper arm
- 10. RH operating arm
- 11. Yoke
- 12. Wiper gear motor
- 13. Crank
- 14. Connecting rod
- 15. Spacer spring
- 16. Inserts
- 17. Relay casing

- 18. Relay armature
- 19. Conductive plate
- 20. Contact mounting plate
- 21. Base plate
- 22. Relay winding
- 23. Resistor
- 24. Breaker bracket
- 25. Breaker bimetal plate
- 26. Gear shaft
- 27. Gear motor wheel
- 28. Spring plate

- 29, 30 - Contact posts
- 31. Cover
- 32. Armature shaft
- 33. Gear motor cover
- 34. Blade
- 35. Blade holder
- 36. Permanent magnet
- 37. Felt ring
- 38. Thrust bearing
- 39. Bush
- 40. Housing

- 41. Armature, motor
- 42. Cover securing plate
- 43. Commutator
- 44. Windscreen washer motor
- 45. Windscreen wiper motor
- 46. Thermal bimetal fuse
- 47. Ignition switch
- 48. Ignition relay
- 49. Fuse box
- 50. Windscreen wipe/wash switch
- 51. Intermittent wipe relay

- A. Pin numbers in relay / wiper motor connector
- B. Pin numbers in wiper switch connector
- I. Wiper gear motor M3-241
- II. Windscreen wiper relay PC-514
- III. Operation diagram of windscreen wipe / wash motors

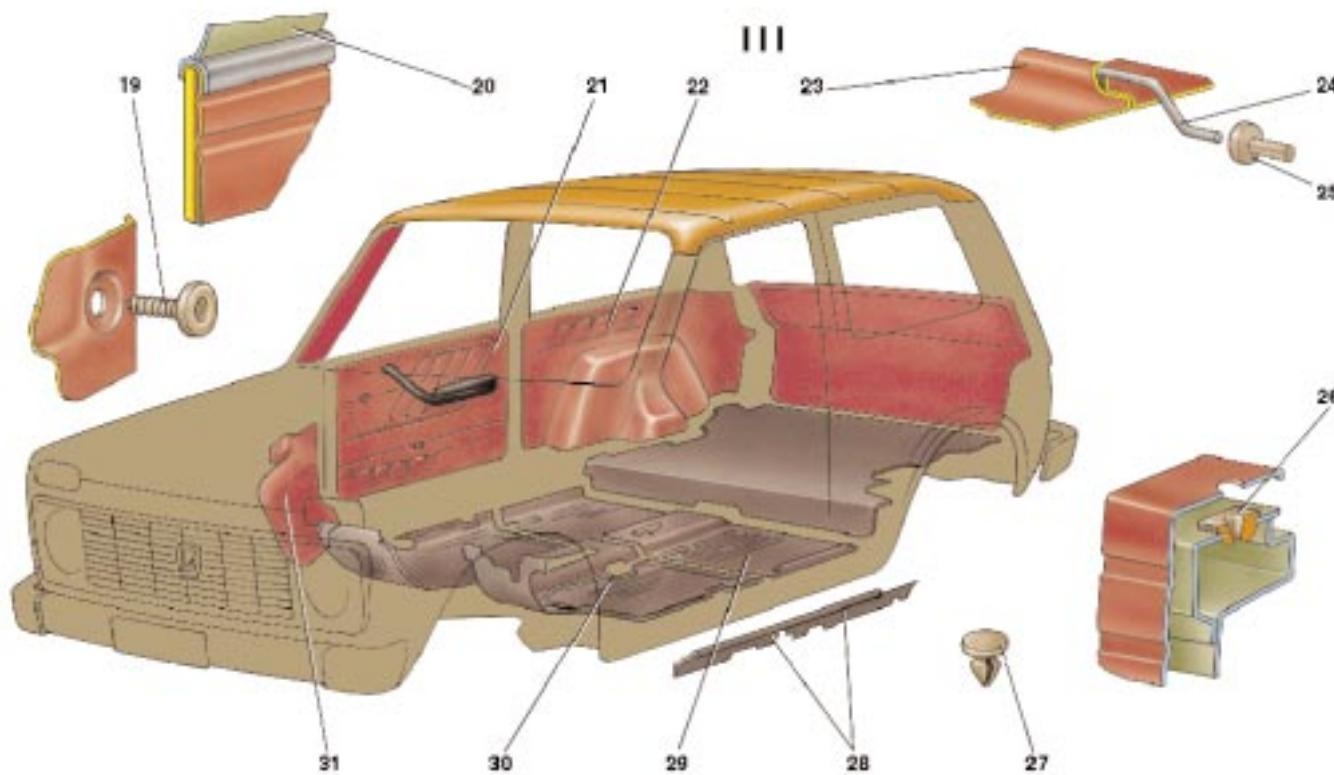
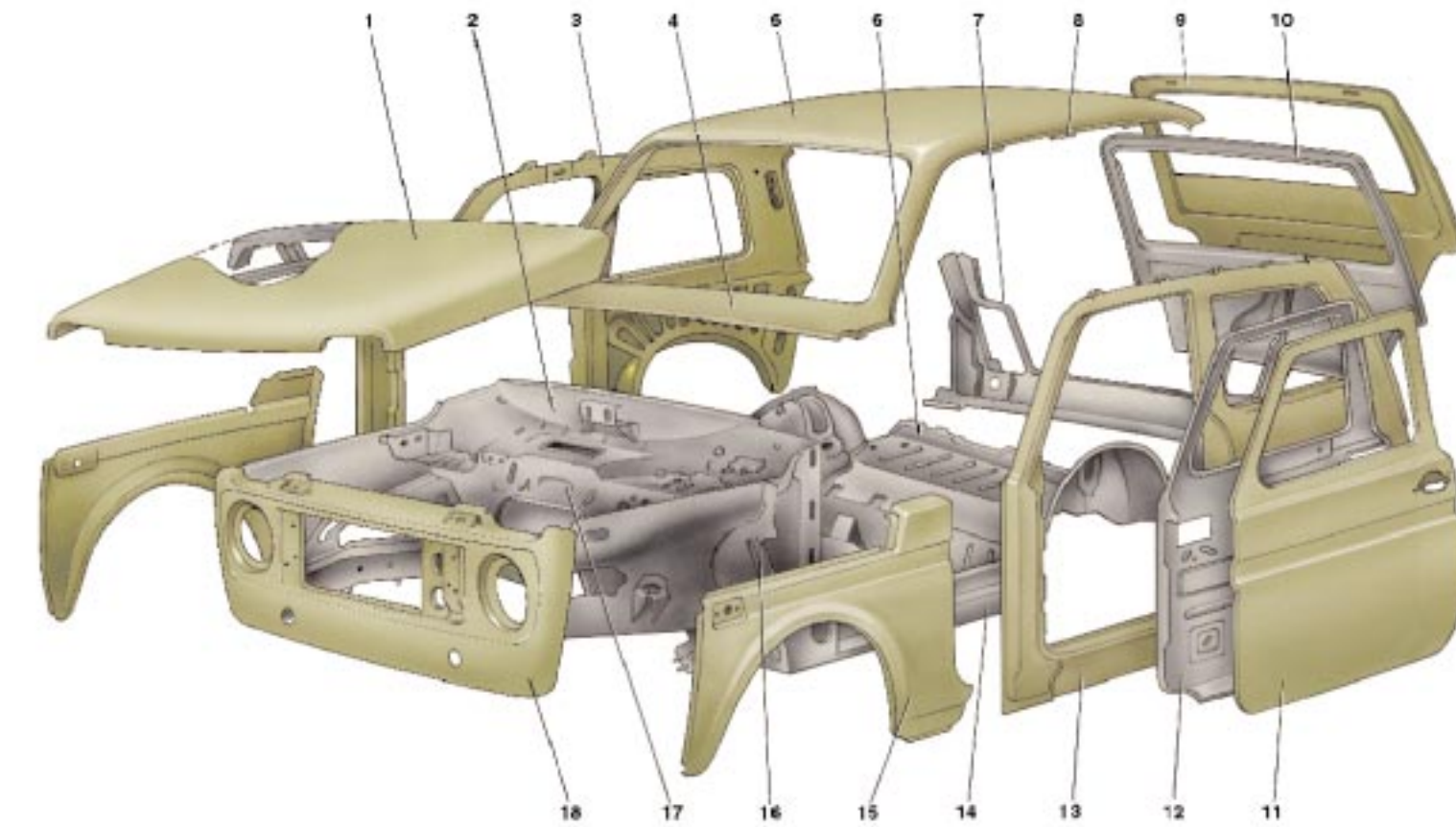

BODY

- 1. Bonnet
- 2. Upper bulkhead stiffener
- 3. RH body side
- 4. Windscreen scuttle panel
- 5. Roof panel
- 6. Rear floor panel
- 7. Rear body side post
- 8. Roof stiffener

- 9. Tailgate outer panel
- 10. Tailgate inner panel
- 11. Side door outer panel
- 12. Side door inner panel
- 13. LH body side
- 14. Floor - to - body side connection
- 15. Front wing
- 16. Front inner wing
- 17. Bulkhead
- 18. Radiator trim panel

- 19. Securing clip
- 20. Upper door trim retainer
- 21. Door trim
- 22. Inner wing and body side liner
- 23. Headliner
- 24. Headliner support
- 25. Bush
- 26. Trim securing clip
- 27. Floor carpet retaining clip
- 28. Door sill trim

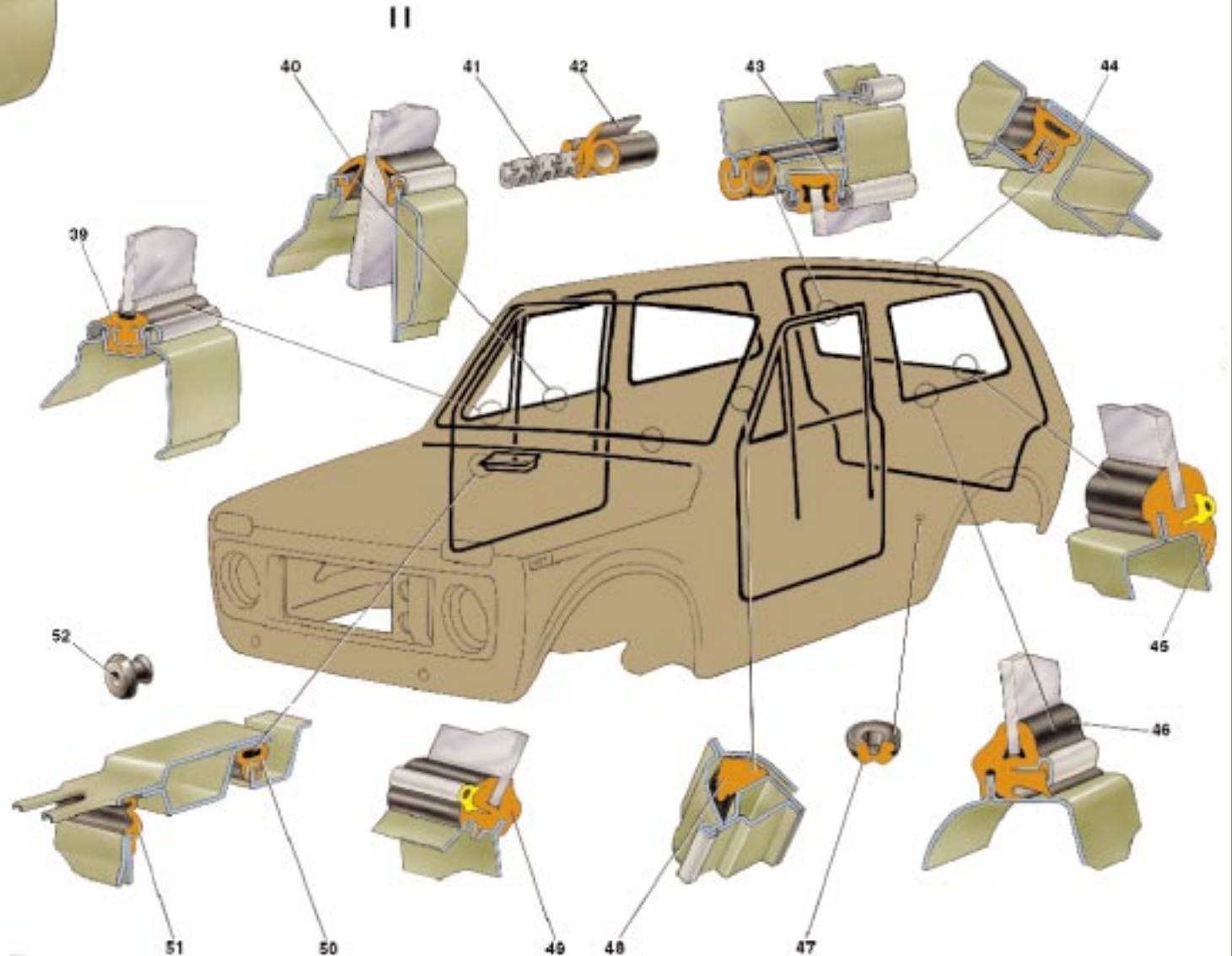
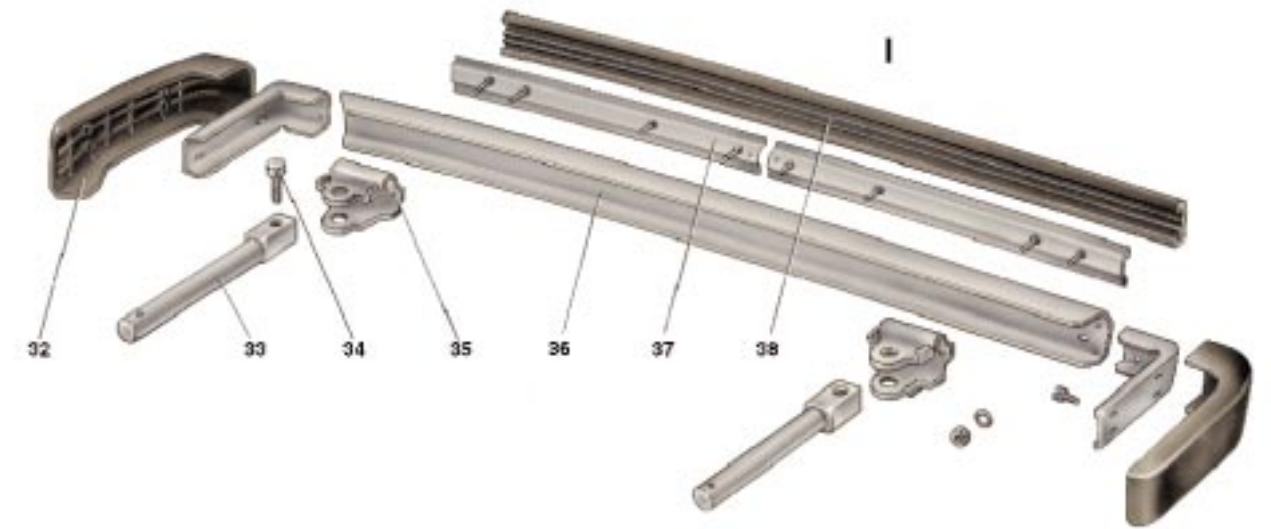

- 29. Rear floor carpet
- 30. Front floor carpet
- 31. Front side panel trim
- 32. Side cover plate
- 33. Connecting piece
- 34. Securing bolt
- 35. Bracket
- 36. Bumper bar
- 37. Retainer
- 38. Rubber cover plate

- 39. Quarter light seal
- 40. Sliding glass lower seal
- 41. Seal cord
- 42. Side door seal
- 43. Sliding glass seal
- 44. Tailgate seal
- 45. Rear window seal
- 46. Side panel glass seal
- 47. Rubber bush
- 48. Windscreen scuttle panel seal

- 49. Windscreen glass seal
- 50. Bonnet seal
- 51. Air box seal
- 52. Seal, front bumper connecting piece
- I. Rear bumper
- II. Rubber seals
- III. Interior trim

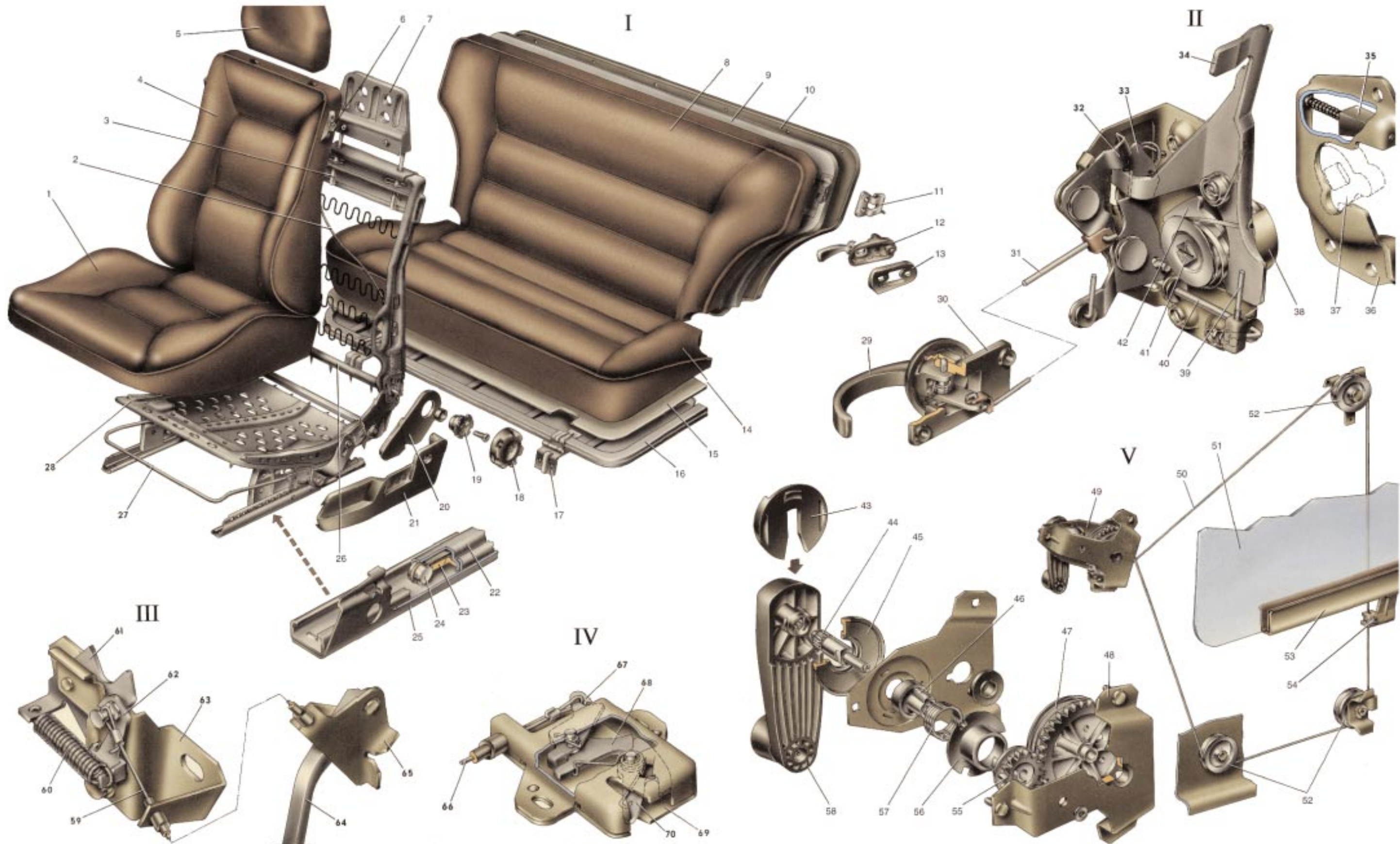

BODY FITTINGS

- 1. Front seat cushion
- 2. Operating rod, seat back fold-down
- 3. Headrest guide
- 4. Front seat back
- 5. Headrest
- 6. Knob, seat back fold-down
- 7. Headrest framework
- 8. Rear seat back
- 9. Seat back base
- 10. Trim

- 11. Seat back brace
- 12. Seat back stop
- 13. Grommet
- 14. Rear seat cushion
- 15. Base-plate
- 16. Cushion pan
- 17. Hinge
- 18. Seat back rake adjuster
- 19. Retainer
- 20. Side trim
- 21. Front seat trim
- 22. Seat slide

- 23. Stop
- 24. Roller
- 25. Seat track with catch
- 26. Seat back crossmember
- 27. Adjuster handle, seat sliding
- 28. Cushion framework
- 29. Door inner handle
- 30. Handle bracket
- 31. Inner handle operating link
- 32. Inner control lever
- 33. Locking rod
- 34. Outer control lever

- 35. Lock striker retainer
- 36. Lock striker
- 37. Rotor
- 38. Centre shaft mounting
- 39. Lock release rod
- 40. Lock release shaft
- 41. Centre shaft
- 42. Ratchet
- 43. Handle trim cover
- 44. Operating shaft
- 45. Surround
- 46. Brake spring dog

- 47. Drum / driven gear
- 48. Window winder cover
- 49. Window winder mechanism
- 50. Cable
- 51. Door glass
- 52. Rollers
- 53. Window glass support channel
- 54. Cable retainer
- 55. Pinion
- 56. Drive shaft mounting
- 57. Brake spring
- 58. Winder handle

- 59. Control cable
- 60. Spring
- 61. Pusher
- 62. Hook
- 63. Lock housing
- 64. Operating handle
- 65. Bracket
- 66. Operating rod
- 67. Return arm
- 68. Arm
- 69. Lock housing
- 70. Rotor

- I. Seats
- II. Front door lock
- III. Bonnet lock
- IV. Tailgate lock
- V. Window winder

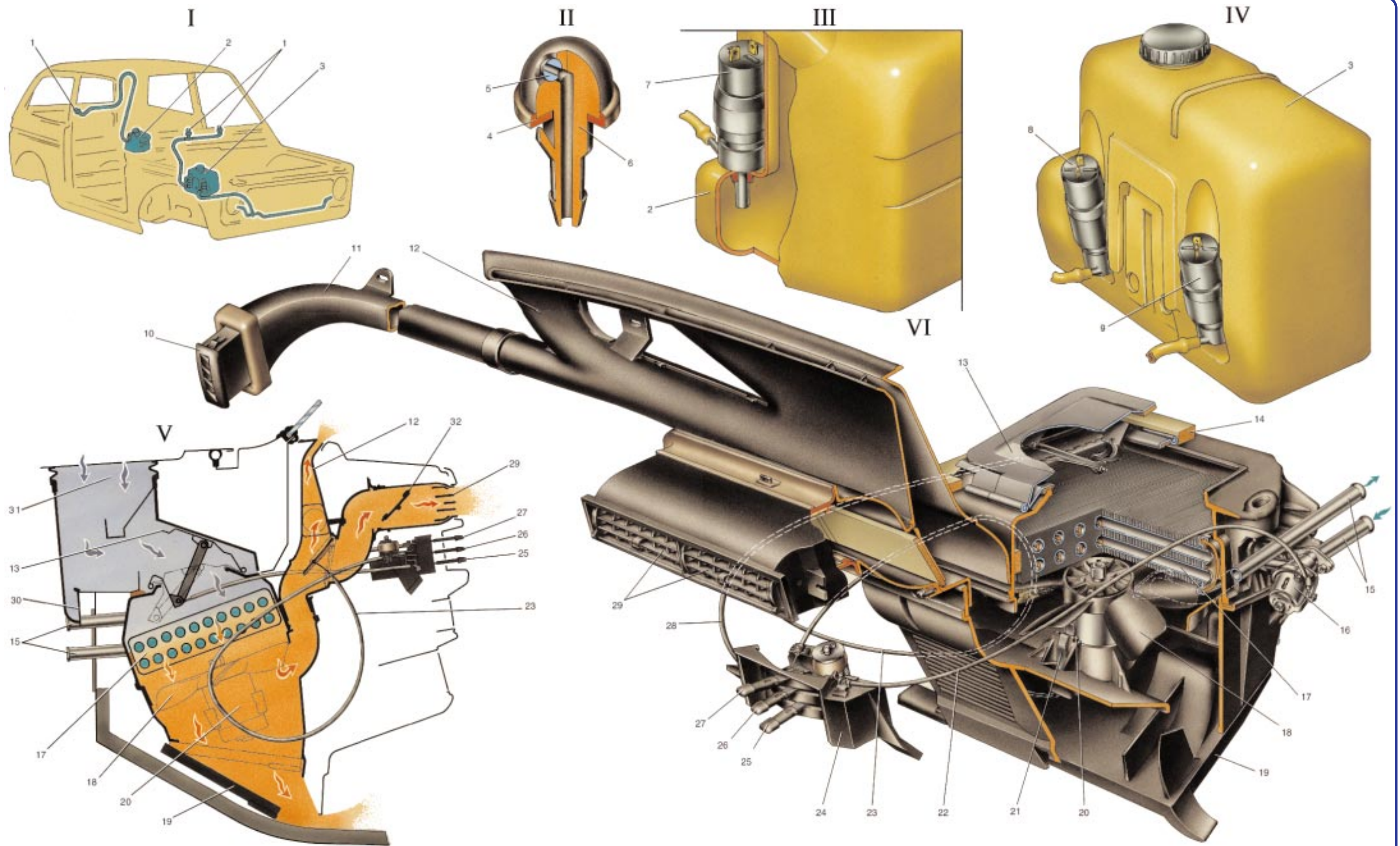

**HEATING AND VENTILATION.
WIPER/WASHER.**

- 1. Washer jet
- 2. Tailgate washer fluid container
- 3. Windscreen/headlight washer fluid container
- 4. Gasket
- 5. Atomizer
- 6. Jet body

- 7. Tailgate washer pump motor
- 8. Windscreen washer pump motor
- 9. Headlight washer pump motor
- 10. Side vent
- 11. Side vent air duct
- 12. Windscreen defroster air duct
- 13. Air intake cover
- 14. Gasket
- 15. Supply and return pipes
- 16. Tap

- 17. Radiator
- 18. Impeller
- 19. Air distributor cover
- 20. Fan motor
- 21. Fan spring holder
- 22. Control cable
- 23. Windscreen vent flap control cable
- 24. Bracket, control levers
- 25. Air intake shutter control lever
- 26. Windscreen vent shutter control lever

- 27. Tap control lever
- 28. Air intake cover control cable
- 29. Centre vents
- 30. Rubber valve
- 31. Air box
- 32. Centre vent shutter

- I. Washer locations
- II. Windscreen and tailgate washer jet
- III. Tailgate washer pump and fluid container
- IV. Windscreen and headlight washer pump and fluid container
- V. Ventilation system operation diagram
- VI. Heater unit

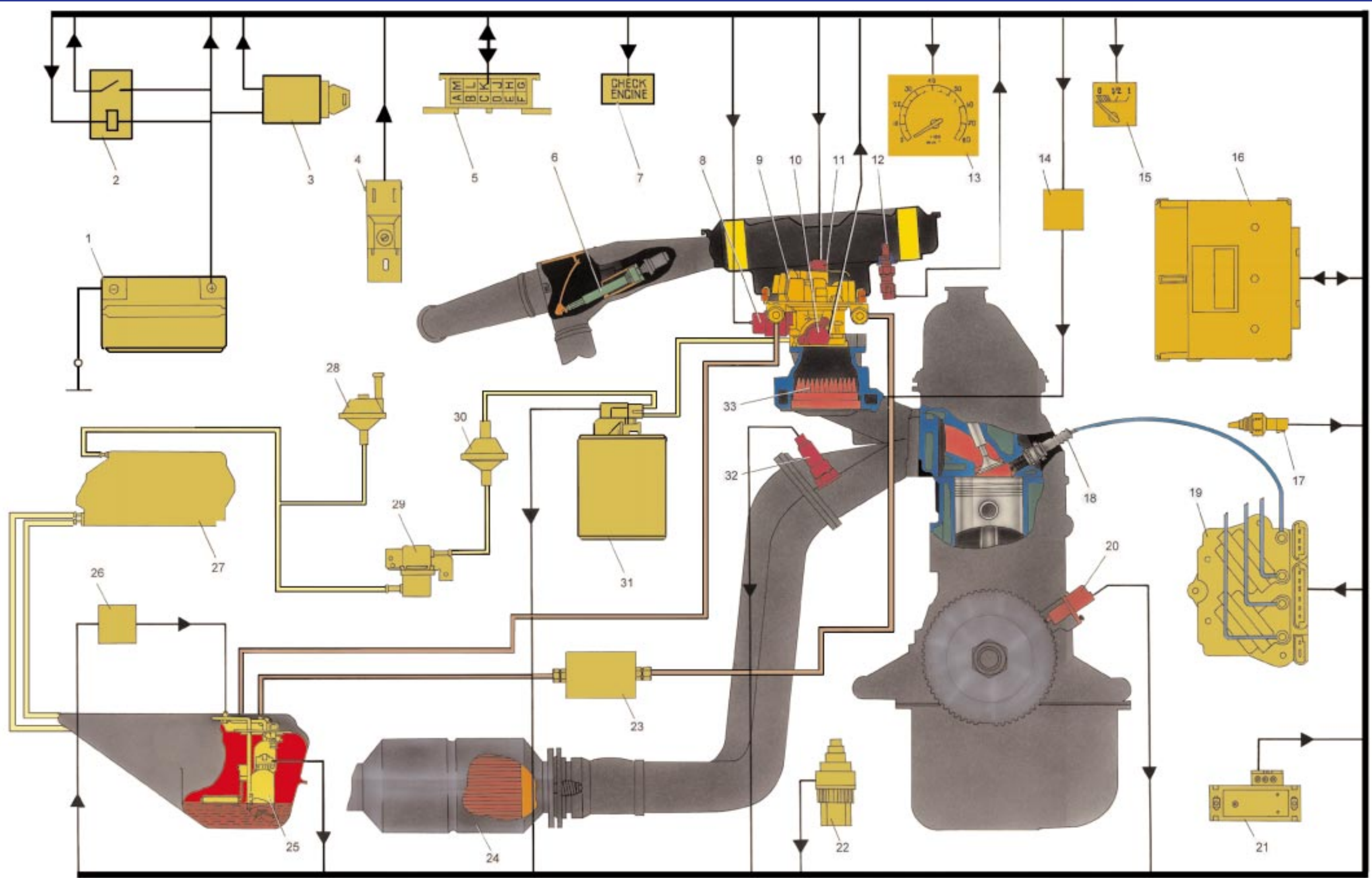

INJECTION SYSTEM DIAGRAM

- | | | |
|--------------------------------------------------------------------------------------------------------------------------------------------------------------------------------------------------------------------------------------------------------------------|----------------------------------------------------------------------------------------------------------------------------------------------------------------------------------------------------------------------------------------------------------------------------------------------------------------------------------------------------------------------------------------------------------------------------------------------------------------------------------------------------------------------------------------------------------------------------------------------------------------------------------------------|---------------------------------------------------------------------------------------------------------------------------------------------------------------------------------------------------------------------------------------------------------------------------------------------------------------------------------|
| <ul style="list-style-type: none"> 1. Battery 2. Ignition relay 3. Ignition switch 4. Octane adjust potentiometer 5. Diagnostic plug 6. Temperature regulator 7. «CHECK ENGINE» warning light | <ul style="list-style-type: none"> 8. Idle air control valve 9. Central injection unit 10. Throttle position sensor 11. Injector 12. Air temperature sensor 13. Tachometer 14. Preheater «ON» relay 15. Fuel level gauge 16. Electronic control unit 17. Coolant temperature sender 18. Spark plug 19. Ignition module 20. Crankshaft position sensor 21. Airflow meter 22. Speed sender 23. Fuel filter 24. Catalytic converter 25. Fuel pump and fuel level sender | <ul style="list-style-type: none"> 26. Fuel pump «ON» relay 27. Fuel vapour separator 28. Pressure-relief valve 29. Gravity valve 30. Two-way valve 31. Canister with electromagnetic purge valve 32. Oxygen sensor 33. Intake manifold preheater |
|--------------------------------------------------------------------------------------------------------------------------------------------------------------------------------------------------------------------------------------------------------------------|----------------------------------------------------------------------------------------------------------------------------------------------------------------------------------------------------------------------------------------------------------------------------------------------------------------------------------------------------------------------------------------------------------------------------------------------------------------------------------------------------------------------------------------------------------------------------------------------------------------------------------------------|---------------------------------------------------------------------------------------------------------------------------------------------------------------------------------------------------------------------------------------------------------------------------------------------------------------------------------|

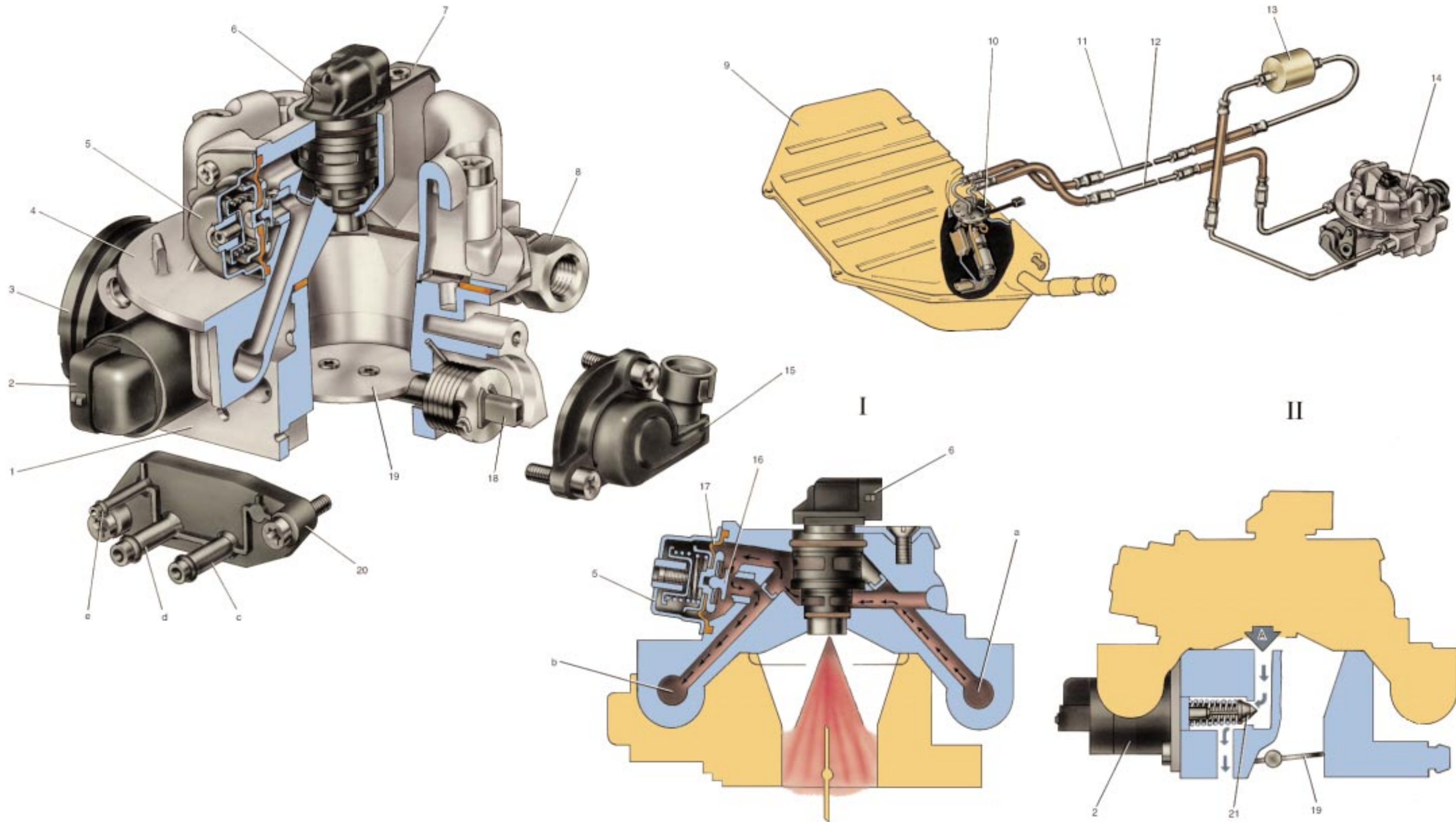

INJECTION SYSTEM

- 1. Throttle valves housing, TBI unit
- 2. Idle speed adjuster
- 3. Throttle operation cam
- 4. Supply unit, TBI
- 5. Fuel pressure regulator

- 6. Injector
- 7. Securing clip
- 8. Pipe union, fuel supply
- 9. Fuel tank
- 10. Fuel pump with fuel level sender
- 11. Fuel supply pipe
- 12. Fuel return pipe

- 13. Fuel filter
- 14. TBI unit
- 15. Throttle position sensor
- 16. Fuel pressure regulator valve
- 17. Diaphragm
- 18. Throttle shaft
- 19. Throttle valve

- 20. Vacuum connection
- 21. Idle speed control valve
- a. Fuel supply port
- b. Fuel return port
- c. Canister purge hose connection
- d. Crankcase ventilation hose connection

- e. MAP sensor hose connection
- I. Fuel pressure regulator operation diagram
- II. Idle air control diagram:
- A - air supply by-passing throttle valve

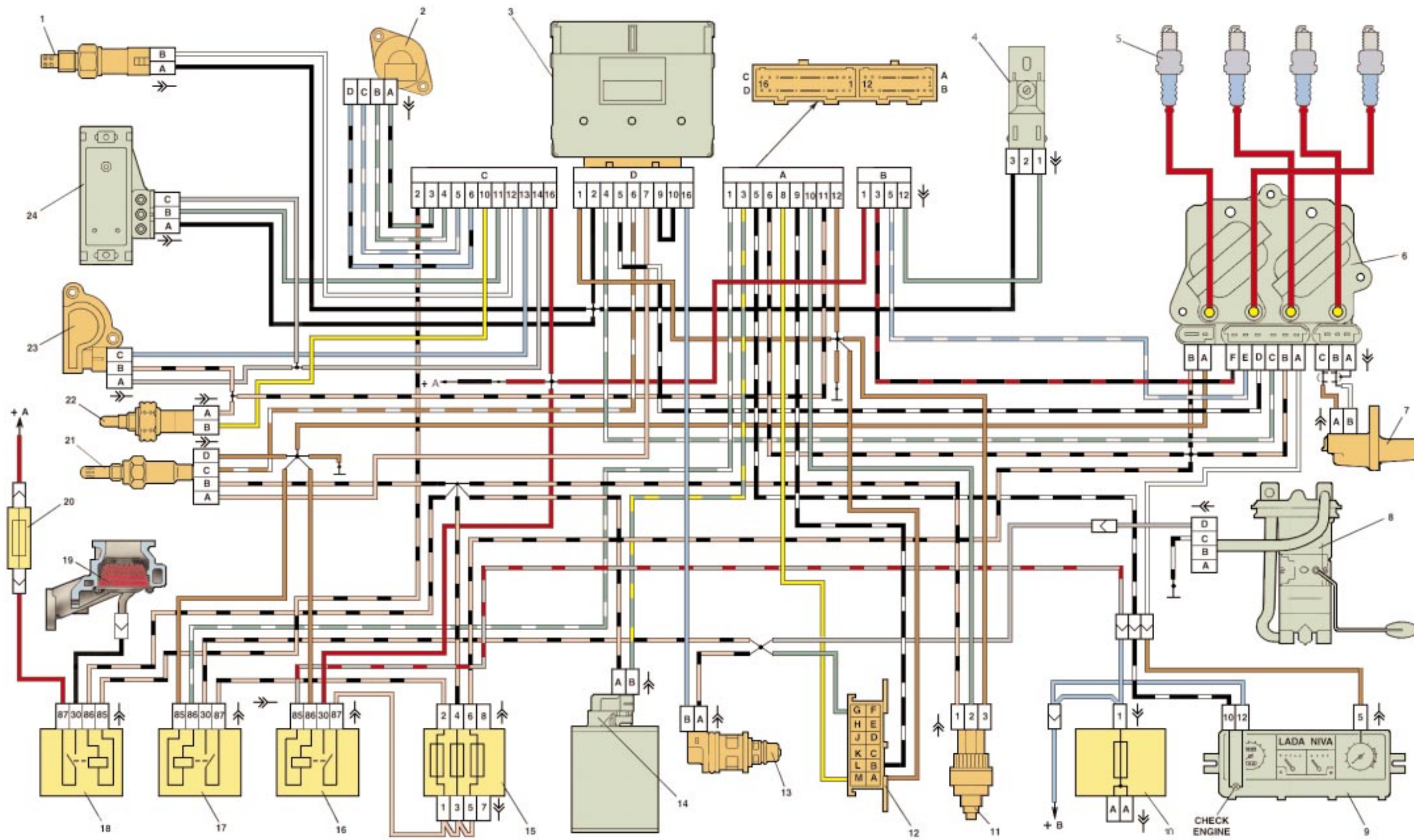

**WIRING DIAGRAM
FOR INJECTION SYSTEM (GM)**

- 1. Air temperature sensor
- 2. Idle speed adjuster
- 3. Electronic control unit (ECU)
- 4. Octane-rating potentiometer
- 5. Spark plugs

- 6. Ignition module
- 7. Crankshaft sensor
- 8. Fuel pump motor and fuel level sensor
- 9. Instrument cluster including tachometer and 'Check Engine' light
- 10. Main fuse box
- 11. Speed sensor
- 12. Diagnostic plug
- 13. Injector

- 14. Canister purge valve
- 15. Injection system fuse box
- 16. Ignition relay
- 17. Electric fuel pump 'on' relay
- 18. Intake manifold preheating relay
- 19. Intake manifold preheater
- 20. Intake manifold preheating fuse
- 21. Oxygen sensor
- 22. Coolant temperature sensor

- 23. Throttle position sensor
 - 24. Manifold absolute pressure (MAP) sensor
- A. To battery '+' terminal
B. To ignition switch '15' terminal

EURO-2
MP7.0, VAZ-21214-10
 (21214-20)

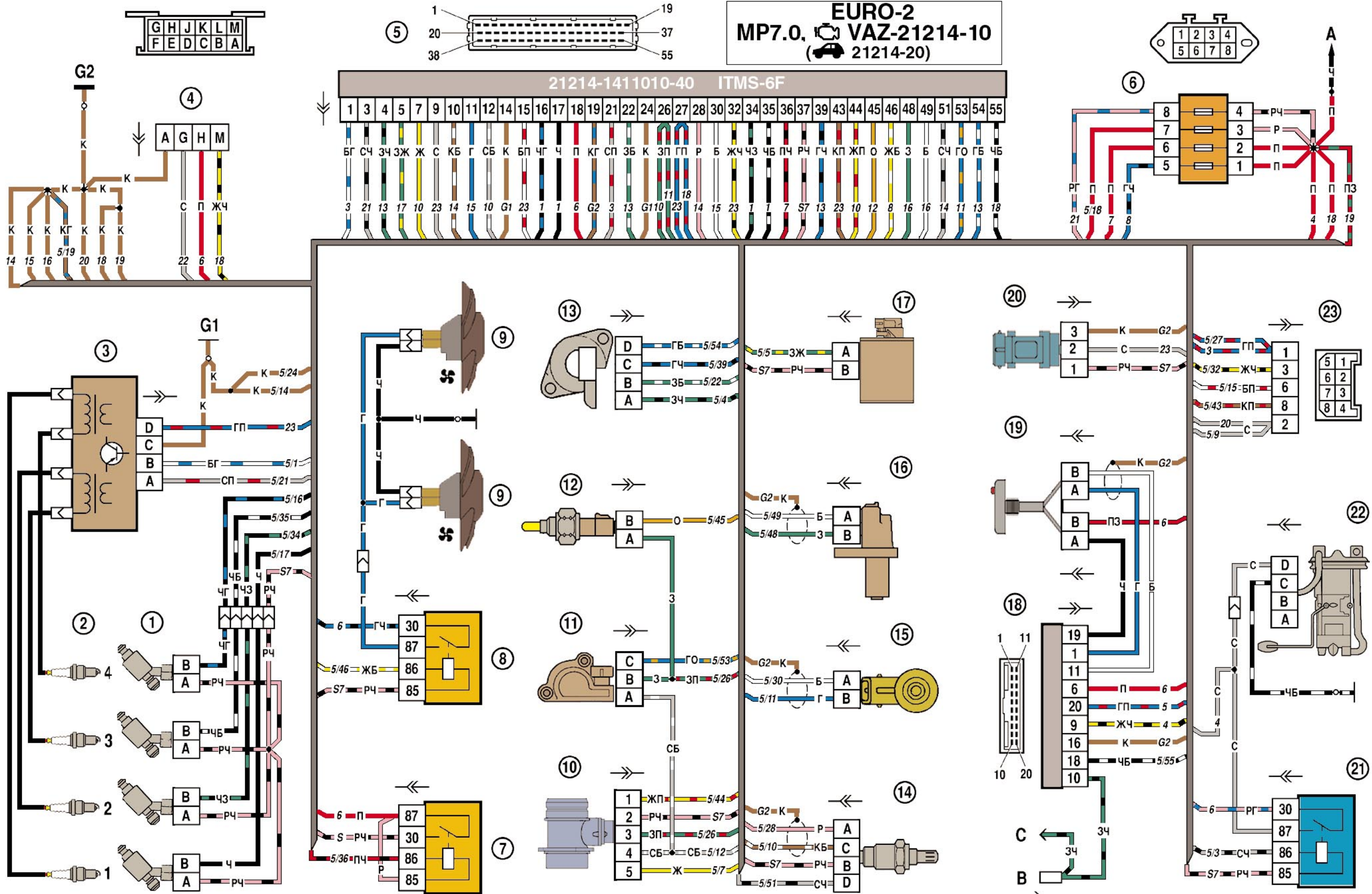

- 1 - Injectors;
- 2 - Spark Plugs;
- 3 - Ignition Module;
- 4 - Data Link Connector (DLC);
- 5 - Electronic Control Module (ECM);
- 6 - Fusebox;
- 7 - Main Relay;
- 8 - Electric Fan Relay;
- 9 - Cooling Fans Motors;
- 10 - Mass Air Flow (MAF) and Intake Air Temperature (IAT) Sensor;
- 11 - Throttle Position (TP) Sensor;
- 12 - Engine Coolant Temperature (ECT) Sensor;
- 13 - Idle Air Control (IAC) Valve;
- 14 - Heated Oxygen Sensor (HO₂S);
- 15 - Knock Sensor (KS);
- 16 - Crankshaft Position (CKP) Sensor;
- 17 - EVAP Purge Solenoid;
- 18 - Immobilizer Control Module;
- 19 - Immobilizer System Key Reader;
- 20 - Vehicle Speed Sensor (VSS);
- 21 - Fuel Pump Relay;
- 22 - Electric Fuel Pump with Fuel Level Sensor;
- 23 - Instrument Panel Connector;

A - to battery terminal «+»;
 B - to courtesy light switch electric connector;
 C - to white/black wire disconnected from the courtesy light switch;
 G1, G2 - Ground Connections.

Alongside letter code of wire color this diagram also has digital marking indicating the number of electrical component to which the wire should be connected, e.g. «-3-». Marking «-S7-» or «-SA-» means that the wire should be connected to component #7 or A, as indicated on the wiring diagram, through the connection not shown on the diagram.

Important:
A different sequence of fuses may be used while assembling the vehicle.

EURO-3
MP7.0 VAZ-21214
 (21214 VERSION S 20-130)

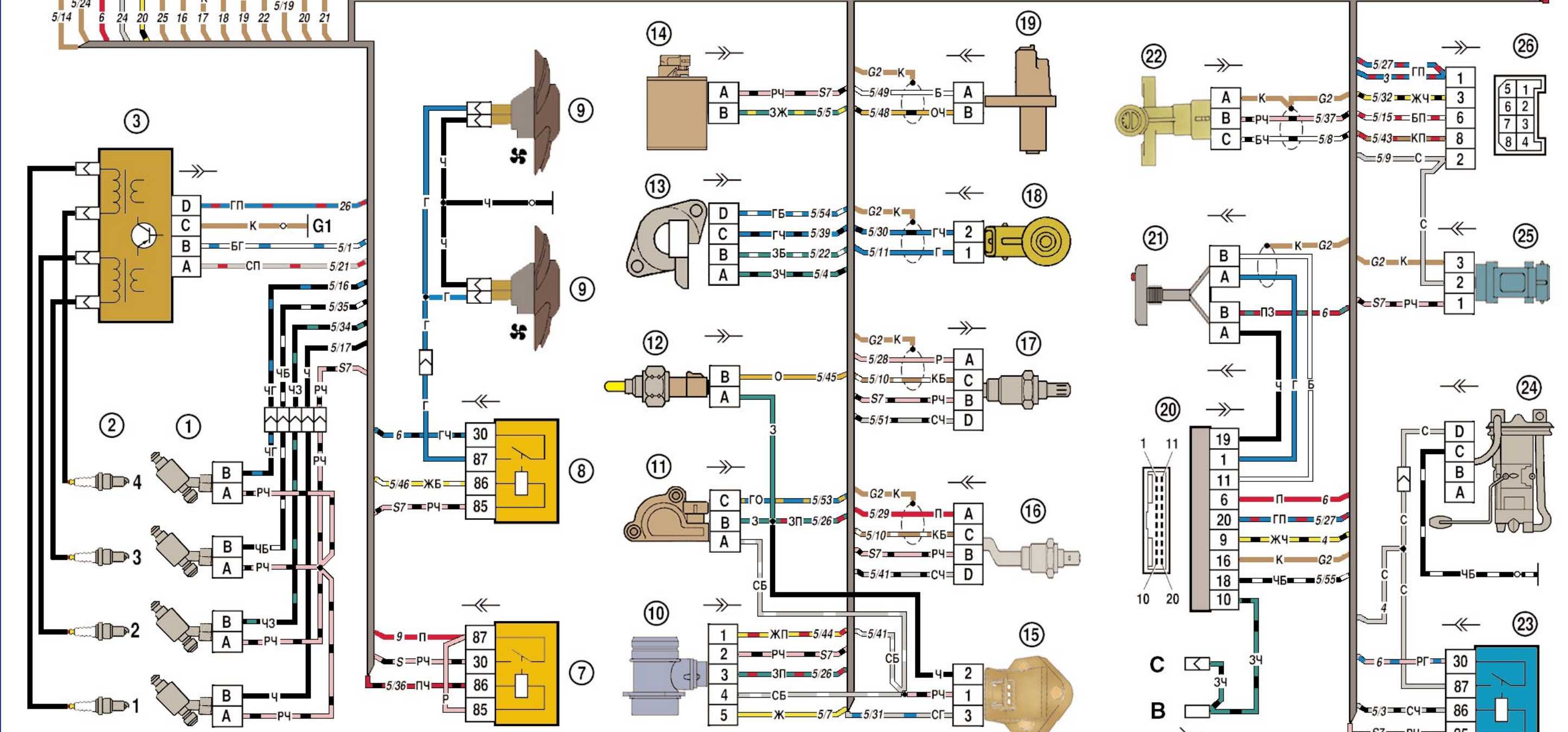
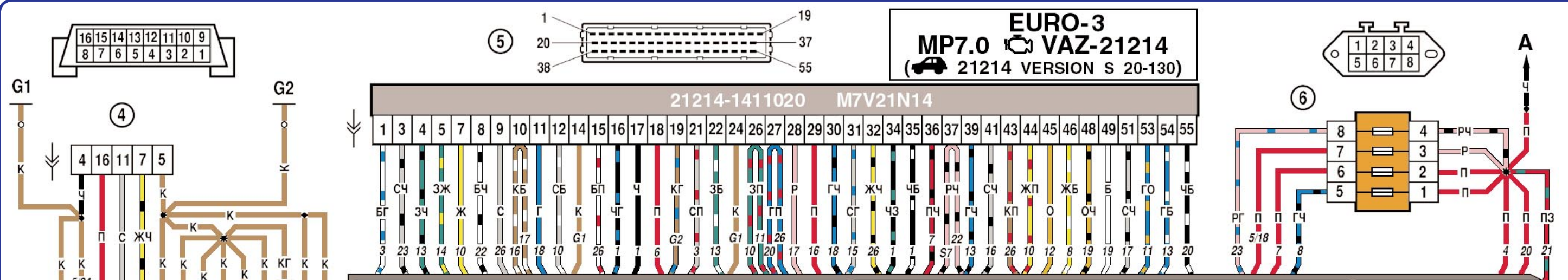

- 1- Injectors;
 - 2- Spark Plugs;
 - 3- Ignition Module;
 - 4- Data Link Connector (DLC)
 - 5- Electronic Control Module (ECM)
 - 6- Fuse Box;
 - 7- Main Relay;
 - 8- Fan Relay;
 - 9- Cooling Fan Motors;
 - 10- Mass Air Flow (MAF) and Intake Air
 - 11- Temperature (IAT) Sensors;
 - 12- Engine Coolant Temperature
 - (ECT) Sensor;
 - 13- Idle Air Control (IAC) Valve;
 - 14- EVAP Purge Solenoid;
 - 15- Rough Road Sensor (G-Sensor);
 - 16- Catalyst Monitor Heated Oxygen Sensor (HO₂S 2);
 - 17- Fuel Control Heated Oxygen
 - Sensor (HO₂S 1);
 - 18- Knock Sensor (KS);
 - 19- Crankshaft Position (CKP) Sensor;
 - 20- Immobilizer Control Module;
 - 21- Immobilizer System Key Reader;
 - 22- Camshaft Position (CMP)
 - Sensor;
 - 23- Fuel Pump Relay;
 - 24- Electric Fuel Pump with Fuel Level Sensor;
 - 25- Vehicle Speed Sensor (VSS);
 - 26- Connector, to instrument panel harness;
- A- to battery terminal "+";
 B- Wiring, to courtesy light switch;
 C- Wiring, to white/black wire disconnected from the courtesy light switch;
 G1, G2 - Ground Connections.
- Alongside letter code of wire color connected to component #7 through this diagram also has digital marking the connection not shown on the diagram indicating the number of electrical gram. Some markings also indicate component to which the wire should pin number (after a slash), e.g. «- be connected, e.g. «-5-». Marking «- 5/15-».
- S7-» means that the wire should be